

TRACTION DECARBONISATION NETWORK STRATEGY

Interim Programme Business Case

31st July 2020

1. PREFACE

Important Notice – This document and its appendices have been produced by Network Rail (NR) in response to a recommendation made by the Rail Industry Decarbonisation Taskforce. The document summarises evidence and analysis carried out by NR in the period between 1st April 2019 and 29th May 2020. This analysis considers technological, operational and economic methodologies to identify the optimum application of decarbonised traction technologies. The document ultimately identifies the optimum deployment of these traction technologies (battery, electrification and hydrogen) on the unelectrified UK rail network. Note that reference to UK railway infrastructure and operations in this document relate to those contained within England, Scotland and Wales and this document does not consider rail operations in Northern Ireland.

The primary purpose of this document and its appendices is to provide DfT, Transport Scotland and Welsh Government with recommendations to inform decisions required to remove diesel trains from the network, achieve net-zero legislative targets, and identify the capital works programme required to achieve this. The document should be used to inform discrete project business cases being developed by project teams. The document provides the strategic rationale for rail traction decarbonisation, as well as initial high-level economic and carbon abatement appraisals of options to underpin the recommendations made. The recommendations have been made using a balanced range of priorities and this work has broad cross industry support.

This document should be used exclusively for the purposes of informing further development activity to be carried out by the rail industry. Any person who obtains access to this document and its appendices accepts and agrees that it has been produced by NR in accordance with the instructions provided in an agreement with a cross-industry programme board and was produced exclusively for the benefit and use of DfT, Transport Scotland, Welsh Government and others within the rail industry for the purposes set out above.

It should be noted that the recommendations within this report will change as further analysis is carried out, with an update to be provided in the TDNS Programme Business Case. Whilst cost and benefit assessments have been provided, the recommendations made as part of this document have not had any significant bottom-up development or deliverability assessment carried out and assume that the current general service provision of the network is maintained. This work has been endorsed by a number of industry partners and ratified by the TDNS Programme Board.

DOCUMENT CONTROL	
Document Title	Traction Decarbonisation Network Strategy – Interim Programme Business Case
Version and date	C02 - Final
Author	System Operator Strategic Planning (FNPO)
Security Level	Official

2. FOREWORD

It is overwhelmingly accepted that the global climate is changing due to human impact. The scientific evidence is increasingly clear. Every year, across the planet, weather records are broken and there is increased incidence of extreme weather events such as flooding and drought. There is an increasingly strong demand for urgent action by populations across the world, to protect the planet and future generations.

The UK government set out in June 2019 its legal commitment to achieve 'net zero' greenhouse gas emissions by 2050. In respect of the railway, in 2018 the DfT challenged the rail industry remove all diesel-only trains from the network by 2040. The Scottish Government has set a target to decarbonise domestic passenger rail services by 2035.

The railways in Great Britain play a critical role in supporting the economy and connectivity between communities across Britain. Rail is a relatively environmentally friendly mode of transport, but we need to do more, and we need to be part of the solution to the climate change challenge.

Over the last year the rail industry has come together collaboratively and constructively, under the co-ordination of the System Operator, to assess the issues and options for removing all diesel trains from the rail network. The result of this work is the Traction Decarbonisation Network Strategy and I am delighted that we can now set out the rail sector's response to the climate challenge by outlining how we can end the direct emissions of greenhouse gases from trains on the network.

This document, and other supporting material being provided as part of the Traction Decarbonisation Network Strategy, will support the decisions on what needs to be achieved, and by when. The Strategy considers where overhead electrification, battery or hydrogen trains might be most effectively deployed.

The work to end greenhouse gas emissions will require a commitment to a long-term, stable and efficient programme of works which will last at least the next thirty years. In order to meet the UK government's commitment to achieve net zero by 2050, and any interim emissions targets along the way, we need to set the wheels in motion.

One of the key things we pledged when we started work on the Strategy was that we would be open and transparent and that the work would involve the industry as a full part of the process. As a result, the work to produce the Strategy has been overseen by a Programme Board comprised of representatives from across the industry. We have also engaged with over two-hundred and fifty different organisations from both within the rail industry and outside of it, including a number of UK Government departments and other infrastructure managers from around Europe.

Much more work will be needed beyond the Strategy, including the development of Regional delivery plans, but this document outlines the journey we must take together. We must now move forward with focus, determination and collective will to see rail rise to the climate change challenge and to maintain its position as a critical and environmentally friendly mode of transport.



A handwritten signature in blue ink that reads "Paul McMahon". The signature is written in a cursive, flowing style.

Paul McMahon
Managing Director – System Operator
Network Rail

3. CONTENTS

5.	Strategic Case	2	6.8	Economic case limitations.....	117
5.1	Strategic Case: Summary.....	2	6.9	Economic Case: Conclusions ..	119
5.2	Context	7	7.	Commercial Case	121
5.3	Case for Change.....	24	7.1	Introduction	121
5.4	Strategic Objectives.....	36	7.2	Network Rail Capability.....	122
5.5	Strategic Benefits	43	7.3	Supply Chain Capability.....	122
5.6	Decarbonisation Traction Options 59		7.4	Delivery Structures and Procurement	125
5.7	Methodology	73	7.5	Commercial Case: Conclusions 126	
5.8	Traction Decarbonisation Recommendations	76	8.	Financial Case	128
5.9	Recommendations – Scotland’s Railway	82	8.1	Financial Case: Summary	128
5.10	Recommendations - Eastern	82	8.2	Spend Profile	128
5.11	Recommendations - Southern 84		8.3	Financial Case: Conclusions....	132
5.12	Recommendations – Wales and Western.....	85	9.	Management Case.....	134
5.13	Recommendations – North West and Central.....	85	9.1	Management Case: Summary	134
5.14	Traction Decarbonisation Programme.....	86	9.2	Programme of Decarbonisation 134	
5.15	Strategic Case: Conclusion....	87	9.3	Governance	139
6.	Economic Case	90	9.4	Project Business Case Development.....	139
6.1	Economic Case: Summary	90	9.5	Further Synergies	141
6.2	Introduction.....	91	9.6	Management Case: Conclusions 141	
6.3	Pathways Appraised	93		Appendix 1 – Network Rail Regions and Service Overview.....	143
6.4	Economic Approach	97		Appendix 2 – Rolling Stock Tables....	149
6.5	Economic Outputs	105		Appendix 3 – Decarbonisation Programme (Non-Traction).....	154
6.6	Analysis of Outputs	110		Appendix 4 – Sub-Regional Context and Emissions Targets.....	156
6.7	Sensitivities.....	115			

Appendix 5 – Strategic and Economic Benefits 161

Appendix 6 – Traction Types Technical Summary 164

Appendix 7 – Embodied Carbon and Ethics 180

Appendix 8 – Traction Decarbonisation Recommendations Regional Breakdown 182

Appendix 9 – Strategic Assumptions, Risks and Opportunities 240

Appendix 10 – Economic Model Sources 246

Appendix 11 – Acronyms and Glossary
247

4. EXECUTIVE SUMMARY

Alongside the current global health crisis, climate change is one of the biggest issues for today's society, with the world facing a climate emergency. The UK Government in 2019 became one of the first nations to establish a legally binding net-zero emissions target. In response to this, all sectors of the UK economy are beginning to outline the infrastructure work and investment which is required to achieve this target.

Although rail contributes less than 1% of the total UK annual greenhouse gas emissions it is in the unique position of currently being the only transport mode capable of moving both people and heavy goods using a zero-carbon solution. As a result, rail has a huge potential role to play in decarbonisation of the UK economy by providing reliable, green transport for goods and people.

Railway traction accounts for the greatest proportion of emissions within rail. With all traction electricity for electric rail services matched by an equivalent amount of nuclear power, the emissions can be considered almost entirely from diesel train operation. For rail to support the UK in achieving its net-zero legislative target, diesel operation will need to reduce and potentially cease.

There are a number of options by which this can be achieved. TDNS is explicitly focused on appraising the identified technologies which can be used to achieve zero emissions. Previous work

undertaken by the Rail Industry Decarbonisation Taskforce (RIDT) has outlined that the viable technologies to achieve this are further electrification and the deployment of battery and hydrogen powered rolling stock.

For areas of the network with significant freight flows or long-distance high-speed services, electrification is the only technology currently able to support these service types. Analysis suggests that electrification is also the best whole life cost solution for more intensively used areas of the network. Away from these areas of operation the deployment of battery and hydrogen rolling stock on both an interim and permanent basis will be critical in achieving decarbonisation of rail.

The extent to which each of these technologies is deployed is outlined in a network map. Electrification is typically measured in Single Track Kilometres (STKs), this is the absolute length of track within a route kilometre (i.e. one route km of twin track railway is 2 STKs). At a holistic level the technology deployment recommendations are that of the 15,400 STKs of unelectrified railway the following allocation is needed to achieve traction decarbonisation.

- An additional 13,000 STKs of electrification.
- Hydrogen train deployment over 1,300 STKs of infrastructure.

- Battery train deployment over 800 STKs of infrastructure.
- There are 300 STKs where a technology choice has not yet been made.

These recommendations would result in residual emissions of around 50 million kgCO_{2e} per year from freight trains operating beyond the proposed electrified network (this is around 3% of today's total traction emissions). The residual emissions from these remaining services would either need to be offset or removed using an alternatively fuelled freight locomotive (which is not currently available in the UK) in order to remove the requirement to electrify almost all of the network.

Unsurprisingly, given the level of infrastructure and rolling stock required to achieve traction decarbonisation, the level of capital investment required is significant. This is detailed within the financial case of this document. The indicative economic analysis contained within this document indicates that costs and benefits for traction decarbonisation are broadly balanced over a ninety-year appraisal period. A number of pathways were modelled with analysis suggesting higher emissions reductions delivered over a longer period of time provide the most optimum value for money outputs.

Whilst a significant investment will be required in the long-term on a national scale there is both a strong strategic and economic rationale for investment in decarbonisation for rail traction.

As well as providing a network map of the proposed technology deployments a number of other recommendations are made.

- Extensions to the rail network consider the need to operate using zero-carbon rolling stock.
- Procurement of diesel-only vehicles is only undertaken where there is clear strategic and economic rationale for doing so.
- Introduction of battery and hydrogen operations to embed whole-system operational experience.
- Continued support for projects and programmes which increase capacity or provide a step-change in capacity to support modal shift.
- Embedding lessons from previous activity, and the use of a smooth and progressive programme of implementation.

This document has been compiled by Network Rail on behalf of the rail industry. Network Rail would like to take this opportunity to thank every individual and organisation who has supported in contributing to this work. This work has been provided as an industry advice document and has been endorsed by the TDNS Programme Board.

This document provides an early stage indicative economic analysis which will be updated and presented in the TDNS Programme Business Case later this year.

5. STRATEGIC CASE

5.1 STRATEGIC CASE: SUMMARY

Despite the current global health crisis, climate change remains one of the biggest issues to face today's society, with the world facing a climate emergency. Science has shown that decisive action is required to reduce emissions of greenhouse gases on a global scale if significant changes to our climate are to be averted. In recognition of this, the leaders of the world's countries came together in 2015 and collectively agreed to limit global average temperature increase to well below 2°C with an ambition to limit this growth to less than 1.5°C. Climate science has shown that the increase in global average temperatures will exceed 1.5°C from as early as 2030. Equally, forecasts indicate that if globally no action is taken, global average temperature rise could be greater than 5°C by the end of the century, posing significant risks to all life on Earth.

In response to the commitments made in the 2015 Paris Climate Agreement, the UK government in 2019 became one of the first nations to establish a legally binding net-zero emissions target. In response to this, all sectors of the UK economy are beginning to outline the infrastructure work and investment which is required to achieve this target.

Overall, rail contributes less than 1% of the annual greenhouse gas emissions of the UK and rail is one of the greenest modes of transport available. As a result, rail has a huge potential in decarbonisation of the economy through increasing the volume of goods and people transported by rail in the UK as a result of a modal shift to rail. The challenges faced by other sectors of the economy such as agriculture and aviation mean that it is highly likely that all other sectors of the economy will be required to reach virtually zero or zero greenhouse gas emissions if the national net-zero emissions target is to be achieved.

Railway traction accounts for the greatest proportion of emissions within rail. With all traction electricity for electric services matched by an equivalent amount of nuclear power, the emissions can be considered almost entirely from diesel train operation. Work undertaken on behalf of the rail industry and published by the Rail Industry Decarbonisation Taskforce has identified that it is possible to remove all diesel-only passenger trains from the network by 2040 and all forms of diesel passenger trains by 2050 through the deployment of battery, electric and hydrogen infrastructure and rolling stock. For freight the challenge to remove diesel is greater, but rail offers the only freight mode where a zero-carbon option is readily available. Achieving traction decarbonisation as a whole will require a significant investment both in infrastructure and rolling stock.

The purpose of the Traction Decarbonisation Network Strategy is to build upon the work completed by the Rail Industry Decarbonisation Taskforce, specifically exploring which of the recommended zero emission traction technologies can be deployed where, and when, in order to optimise reduction of direct rail traction greenhouse gas emissions. In order to do this, a Programme Business Case (PBC) will be provided by the end of 2020 covering the five aspects of the business case: Strategic, Economic, Commercial, Financial and Management. This TDNS – Interim Programme Business Case outlines the first two of these aspects in detail (strategic and economic) and begins to introduce the thinking and work being undertaken by both Network Rail and the wider rail industry in the remaining three aspects. The PBC will outline the commercial, financial and management cases in greater detail and provide a refreshed economic case.

The Strategic Case focuses on the strategic rationale for traction decarbonisation, exploring in much greater detail the climate change and decarbonisation context and work completed to date as outlined above. It also provides context of the UK rail network and how it functions, as well as a summary of the Network Rail Regions and Routes and the services which operate through them. The case then describes the strategic rationale for rail traction decarbonisation including the role rail can play in overall transport decarbonisation. Using six key themes it discusses the case for change, strategic objectives and strategic benefits for rail traction decarbonisation; these are summarised in Figure 1 at the end of this section.

There are a number of potential options by which traction decarbonisation can support in delivering both interim emissions targets and zero emissions. TDNS is explicitly focused on appraising the identified technologies which can be used to achieve zero emissions. Previous work has outlined that the viable technologies by which to achieve this are further electrification and the deployment of battery and hydrogen powered rolling stock. Whilst these technologies form the basis of the analysis and recommendations, other solutions which can be used to support or achieve decarbonisation are also outlined. Any discrete project development work undertaken as a result of TDNS should take cognisance of all options during the appraisal process.

The outputs of TDNS are built on the foundations of previous technical work and technologies have only been considered where it is appropriate to deploy them. This means that for areas of the network with significant freight flows or long-distance high-speed services electrification is recommended, as this is the only technology currently able to support these service types. A number of areas where battery and hydrogen rolling stock would be most appropriate are also identified. For the remaining areas of the network, economic and operational considerations have either indicated an appropriate technology or identified that it is currently not possible to commit to a technology.

The methodology for this approach is described in detail and the national recommendations for the unelectrified network are outlined. These recommendations are end-state and a feasible delivery programme and associated transition plan has, at this stage, only been outlined. This will be worked through in detail over the coming months with a more detailed programme of decarbonisation outlined in the TDNS PBC. This programme may require interim solutions to be deployed in some areas and this will be outlined within the PBC.

A national map of the recommendations is provided within section 5.8 with regional breakdowns and commentary provided in Appendix 8. At a holistic level they recommend that to achieve traction decarbonisation of the c. 15,400 STKs of unelectrified network:

- an additional c. 11,700 STKs of electrification is required for long-distance high-speed passenger and freight services;
- hydrogen train deployment over c. 900 STKs of infrastructure;
- battery train deployment over c. 400 STKs of infrastructure; and
- there are 2,400 STKs where a single technology choice is not immediately clear.

Of this 2,400 STKs further analysis suggests the deployment of:

- a further c. 1,340 STKs of electrification;
- hydrogen train deployment over c. 400 STKs of infrastructure;
- battery train deployment over c. 400 STKs of infrastructure; and
- there remains 260 STKs where a technology choice remains unclear.

Whilst these recommendations are extensive, there are a number of areas where freight services would operate beyond the proposed electrification. Modelling suggests this residual emission to be around 50 million kgCO₂e per year (this is around 3% of today's total traction emissions). The residual emissions from these remaining services would either need to be offset, or removed using an alternatively fuelled freight locomotive (which is not currently available in the UK) in order to remove the requirement to electrify almost all of the network.

As well as providing maps of the proposed technology deployments, a number of other national recommendations are made.

- Following recent announcements and the focus on extending the existing rail network, it is recommended that any new railway being proposed considers the need to operate using zero carbon rolling stock (i.e. battery, electric or hydrogen), in conjunction with the wider network to which it is linked.
- Procurement of diesel only vehicles should only be made where there is clear strategic and economic rationale for doing so.

- Hybridisation and the use of multi-mode trains offer an excellent opportunity to progressively realise both emissions reduction and the benefits of electrification and as such, whilst not an optimum long-term solution, should be considered in conjunction with the programme of electrification projects.
- Best practice design, as is seen in current multi-modes, is to provide a flexible arrangement where diesel generator sets, or engines, can be completely removed or replaced with a zero-carbon alternative.
- It is recommended that battery and hydrogen train operations commence to ensure standards are developed, whole-system operational experience is gained, and lessons are learned, so that best practice can be embedded as part of the required longer-term introduction of these units.
- Projects and programmes which increase capacity for both passenger and/or freight should continue in order to support modal shift to rail.
 - These projects and programmes could draw on the strategic and economic benefits of decarbonisation/modal shift as part of their own business case.
 - This is especially true for freight projects which encourage modal shift of goods to rail.
- In order to ensure efficient delivery of traction decarbonisation a smooth and progressive programme is recommended whilst embedding lessons from previous activity. This programme is likely to include interim solutions to best use resources and keep disruption to the network to as low a level as possible, whilst realising reduction of emissions in line with targets. This programme will be considered as part of the TDNS Programme Business Case.



Figure 1: Traction Decarbonisation strategic themes, the case for change, strategic objectives and benefits.

5.2 CONTEXT

COVID-19

- 5.2.1 The current global health crisis has caused a significant degree of uncertainty around the short-term future of the economy and the associated impacts this may have on future passenger and freight growth on the railway.
- 5.2.2 The current crisis has also highlighted the extent of the challenge of decarbonisation and the intensity of change which will be required to achieve decarbonisation targets¹. The need to focus on growing a green economy as part of the Covid-19 recovery has been identified as critical by organisations including the United Nations² and the UK Government³.
- 5.2.3 The rail industry continually reviews and updates strategic advice, and Network Rail will continue to work with funders and the wider industry to ensure the rail network continues to support society and the economy in the long-term as it transitions to a zero-carbon future.

GLOBAL CLIMATE CHANGE

- 5.2.1 Changes to the global average temperature and the climate system have been understood for a long time and the human influence on these aspects has been researched and widely publicised over the last century. The Earth's climate is changing with temperatures rising due to human-induced greenhouse gas emissions into the atmosphere from pre-industrial times⁴.
- 5.2.2 Shifts in climate and temperature have been underpinned by significant scientific research. Some of the key climate change aspects for the UK and the world as a whole are captured overleaf in Figure 2⁵.

¹ Le Quere et al, 2020, Temporary reduction in daily global CO₂ emissions during the Covid-19 forced confinement, Nature Climate Change, p.6

² Speech given by UN Secretary General Antonio Guterres at Petersburg Climate Dialogue, available at <https://www.un.org/sg/en/content/sg/speeches/2020-04-28/remarks-petersberg-climate-dialogue>

³ Speech given by Alok Sharma MP at Petersburg Climate Dialogue, available at <https://www.gov.uk/government/news/cop26-president-remarks-at-first-day-of-petersberg-climate-dialogue>

⁴ Committee on Climate Change, 2019, Net Zero – The UK's contribution to stopping global warming, p. 58.

⁵ Committee on Climate Change, 2019, Net Zero – The UK's contribution to stopping global warming.

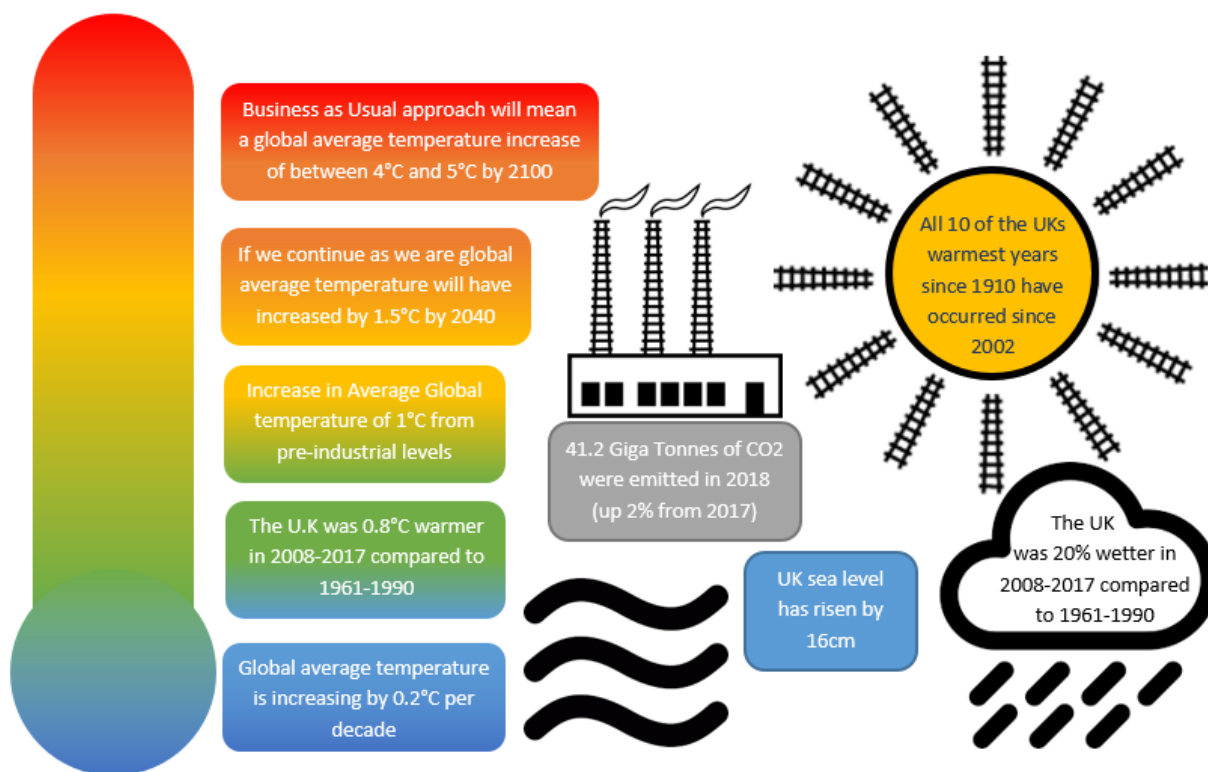

Figure 2: Summary of climate change and global average temperature and the impacts on the UK

5.2.3 Climate change is bringing about significant, widespread changes which are impacting the world today. If the rate of change continues and global temperatures continue to increase, new risks will be introduced to the world⁶. The key issues and risks associated with climate change are:

- significant loss of ice cover increasing global average sea level⁷ and decreasing salinity of ocean water affecting oceanic water flows and impacting mid-latitude climates⁸;
- increases in severe weather events such as stronger storms, more intense heatwaves, prolonged droughts and significant shifts in rainfall patterns⁹;
- effects on crop yields with more negative impacts than positive¹⁰; and
- impacts to habitats of plant and animal species causing geographical and migratory changes, increased risks of forest fires, and ultimately driving a number of species towards extinction.¹¹

⁶ Committee on Climate Change, 2019, Net Zero – The UK's contribution to stopping global warming, p. 58.

⁷ Committee on Climate Change, 2019, Net Zero – The UK's contribution to stopping global warming, p. 60.

⁸ UK Met Office, Sea Ice in the climate system, <https://www.metoffice.gov.uk/research/climate/cryosphere-oceans/sea-ice/index>

⁹ Committee on Climate Change, 2019, Net Zero – The UK's contribution to stopping global warming, p. 58.

¹⁰ Committee on Climate Change, 2019, Net Zero – The UK's contribution to stopping global warming, p. 60.

¹¹ UK Met Office, The Effects of Climate Change, <https://www.metoffice.gov.uk/weather/learn-about/climate-and-climate-change/climate-change/impacts/infographic-breakdown/global-impacts-of-climate-change>

5.2.4 These impacts affect the whole global human population as well as the world's wider ecosystems. The risk of crises will continue to increase with the rise of global average temperatures¹². A number of these impacts are being felt today even at an increase of 1°C with further impacts still likely to occur even if global average temperature increase remains at the lowest forecast level of 1.5°C¹³. Recent research has indicated that the increase in global average temperatures will exceed 1.5°C from as early as 2030¹⁴. This demonstrates that in order to restrict average temperature increase to levels with reduced risk, immediate action is required on a global scale affecting all economic sectors of all countries.

UK EMISSIONS

5.2.5 The overall trend of UK emissions over the past 30 years has seen a decline, with a 44% decrease since 1990¹⁵. This has largely been driven by significant focus on decarbonisation of the national electrical grid. Policy decisions to reduce reliance on and ultimately close all coal fired power plants in the UK by 2024¹⁶, coupled with significant investment in renewable and nuclear power has seen the emissions from the UK power grid decrease by 59% since 1990¹⁷.

5.2.6 In a similar vein, whilst some of the reduction in industry emissions is in part due to UK manufacturing decreasing since 1990, significant effort has been made by the industry sector as a whole, with significant emissions reductions through more efficient energy usage and a number of industries moving to onsite power generation using renewable sources¹⁸.

5.2.7 Over the same time period surface transport emissions have remained broadly constant and as a result surface transport is now the highest GHG emitting sector in the UK. Emissions from surface transport have actually increased by 4% since 1990¹⁹.

5.2.8 Surface transport comprises cars and other small vehicles (motorbikes, etc.), vans, HGVs, buses and rail. Cars, vans and HGVs contribute 95% of all surface transport

¹²Committee on Climate Change, 2019, Net Zero – The UK's contribution to stopping global warming, p. 61.

¹³ Committee on Climate Change, 2019, Net Zero – The UK's contribution to stopping global warming, p. 60.

¹⁴ IPCC, 2018, Special Report: Global Warming of 1.5°C – Chapter 1: Framing and Context, p. 66.

¹⁵ Department for Business, Energy and Industrial Strategy, 2019, 2018 UK Greenhouse Gas Emissions - Provisional Figures, p. 2.

¹⁶ Department for Business, Energy and Industry Strategy, 2020, End of coal power to be brought forward in drive towards net zero, available at: <https://www.gov.uk/government/news/end-of-coal-power-to-be-brought-forward-in-drive-towards-net-zero>.

¹⁷ Department for Business, Energy and Industrial Strategy, 2019, 2018 UK Greenhouse Gas Emissions - Provisional Figures, p. 3.

¹⁸ Department for Business, Energy and Industrial Strategy, 2019, 2018 UK Greenhouse Gas Emissions - Provisional Figures, p. 7.

¹⁹ Committee on Climate Change, 2019, Net Zero – The UK's contribution to stopping global warming, p. 140.

emissions, with buses contributing 3% and rail 2%²⁰. Surface transport figures as a whole are thus heavily influenced by road transport. Despite motor vehicles improving emissions levels on a per vehicle basis through improved fuel efficiency and engine emissions controls, the increased numbers of vehicles on the roads has resulted in the steady-state emissions seen in Figure 3 below²¹.

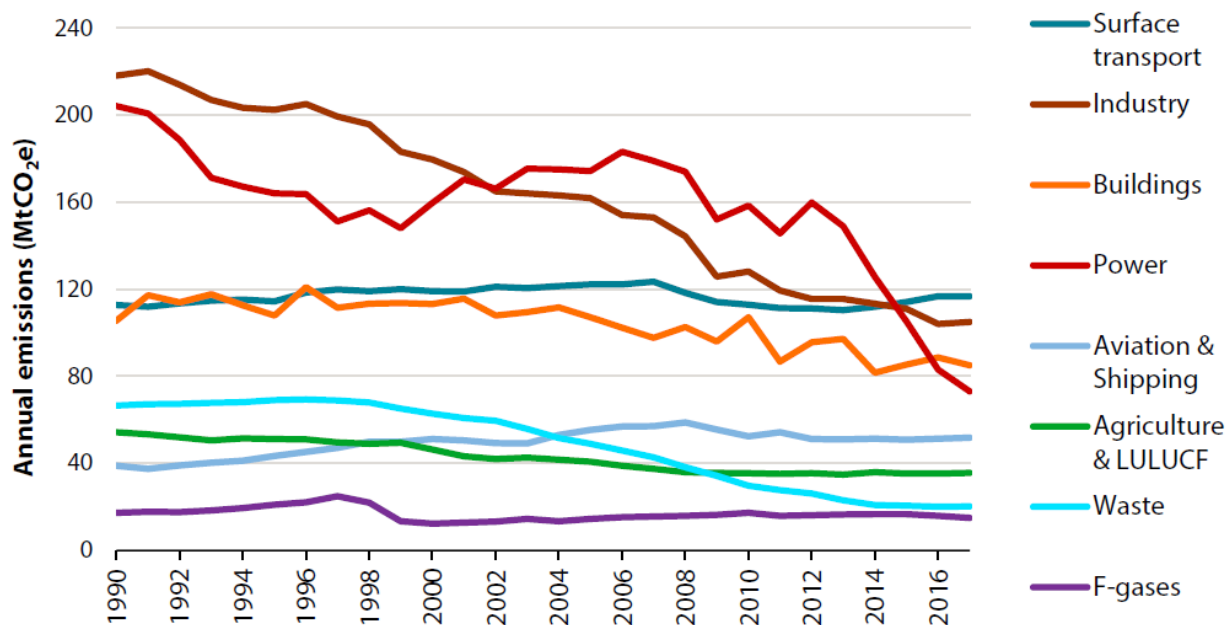

Figure 3 UK Domestic Greenhouse Gas emissions between 1990 and 2017

RAIL EMISSIONS

5.2.9 Rail is one of the greenest modes of transport in the UK²². Rail offers a mass transport solution with relatively low emissions (especially on electrified railways) with one of the lowest emissions per passenger rates in transport²³ and a 76% emission reduction for freight compared with road²⁴.

5.2.10 Within the rail industry around two-thirds of the direct greenhouse gas (GHG) emissions are attributable to traction energy, with the remaining third from

²⁰ Department for Business, Energy and Industrial Strategy, 2019, Final UK greenhouse gas emissions national statistics: 1990-2017.

²¹ Committee on Climate Change, 2019, Net Zero – The UK's contribution to stopping global warming, p. 49.

²² Department for Transport, 2020, Decarbonising Transport: Setting the Challenge, p. 26.

²³ Department for Business, Energy and Industrial Strategy, 2019, Greenhouse gas reporting: Conversion factors 2019.

²⁴ Department for Transport, 2016, Rail Freight Strategy, p. 6.

subsystems dedicated to operating the rail network and station and depot operations²⁵.

UK RAIL NETWORK

5.2.11 The UK rail network covers over 15,800 route kilometres of track, 30,000 bridges, tunnels and viaducts along with thousands of items of associated infrastructure such as signals and level crossings²⁶. There are over 2,500 railway stations²⁷ with over 1.7 billion rail passenger journeys²⁸ and over 16 billion net tonne kilometres of freight moved²⁹ annually.

5.2.12 From a traction power perspective, the UK network comprises four main categories:

- unelectrified – diesel operations;
- electrified with 25,000V AC overhead line equipment;
- electrified with 1,500V DC overhead line equipment; and
- electrified with 650V/750V DC third rail.

5.2.13 Over 6,000 route kilometres of railway are currently electrified with electrified routes accounting for 38% of all railway in the UK³⁰. Figure 4 overleaf shows the extent of the existing electrified UK rail network.

²⁵ Rail Industry Decarbonisation Taskforce, 2019, Initial Report to the Minister for Rail, p. 16.

²⁶ Network Rail, About Us, <https://www.networkrail.co.uk/who-we-are/about-us/>.

²⁷ Network Rail, About Us, <https://www.networkrail.co.uk/who-we-are/about-us/>.

²⁸ ORR, Passenger Rail Usage Statistics, <https://dataportal.orr.gov.uk/statistics/usage/passenger-rail-usage/passenger-journeys-table-125/>.

²⁹ ORR, Freight Rail Usage Statistics, <https://dataportal.orr.gov.uk/statistics/usage/freight-rail-usage-and-performance/freight-moved-table-137-1/>.

³⁰ ORR Rail Infrastructure, 2019, Rail infrastructure and assets 2018-19, p. 3.



Figure 4: UK Rail network showing 25kV electrification in green and 750V DC third rail in yellow

5.2.14 Large-scale electrification projects have increased the extent the of 25kV electrified network, with over 600 additional route kilometres electrified since 2017. Table 1 below summarises the total amount of route kilometres operated electrically since 2012/13³¹.

	2012/13	2013/14	2014/15	2015/16	2016/17 ³²	2017/18 ³²	2018/19
Route Km operated electrically	5,265	5,268	5,272	5,331	5,374	5,766	6,012
Variance on previous year		+3km	+4km	+59km	+43km	+392km	+246km

Table 1: Route kilometres operated electrically with variance from previous year, 2012/13-2018/19

5.2.15 A focus on passenger service quality has formed a key element of rail franchising competitions in the recent past and this has led to a large number of new passenger trains introduced onto the network over the past five to ten years. A number of these trains have bi-mode diesel/electric capabilities, meaning they can use existing electrification and can also operate as diesel services away from the electrified network. Bi-mode and tri-mode freight locomotives have also emerged or are due to be introduced to achieve similar outcomes for freight.

PASSENGER SERVICES

5.2.16 The passenger rolling stock fleet in the UK comprises over 14,000 vehicles with over 70% of these pure electric³³. In 2018/19 passenger rail services consumed 3,976 million kWh of electricity (an increase of 9.1% compared with 2017/18) and 469 million litres of diesel (a decrease of 5.3% compared with 2017/18)³⁴.

5.2.17 Passenger services are operated by Train Operating Companies (TOCs), most of whom deliver services based on specifications outlined by the Department for Transport for England, Transport Scotland for Scotland and Welsh Government for Wales. These are more commonly known as franchises. There are multiple franchises which operate in geographically specific areas. These are awarded to private operators on a fixed-term basis, typically between five and ten years. This

³¹ ORR, Rail Infrastructure and assets statistics, <https://dataportal.orr.gov.uk/statistics/infrastructure-and-emissions/rail-infrastructure-and-assets/infrastructure-on-railways-table-252/>.

³² There is a break in the time series between 2016-17 and 2017-18 due to Network Rail replacing Geogis, its master database for track assets, with a new system called INM (Integrated Network Model). This means any comparison of the current route length with previous years must be treated with caution.

³³ RDG, 2018, Long-term Passenger Rolling Stock Strategy, p. 1.

³⁴ ORR, 2019, Rail Emissions 2018/19 Annual statistical release, p. 2.

operating model may change as part of the recommendations made by the Williams Rail Review³⁵. All franchises are currently under special Emergency Measures Agreements (EMAs), with the UK Government and Transport Scotland bearing risk as a result of the Covid-19 health crisis.

5.2.18 Open Access Operators also run passenger services alongside franchised operators. These organisations bid to run trains in area where there is a perceived service gap and operate on a commercial basis, with no subsidy from Government. Most Open Access Operators operate long-distance high-speed journeys as these are often the most profitable service type. Almost all open access operations services have been suspended as a result of the current Covid-19 health crisis.

FREIGHT SERVICES

5.2.19 The rail freight network in the UK is operated on a commercial basis. Freight Operating Companies (FOCs) operate services on behalf of customers by moving key commodities around the country. There are six principal commodity markets: intermodal, aggregate, automotive, fuels, steel and ores and waste. Most intermodal rail freight moves between coastal ports and inland freight terminals or between inland warehouses across the country, and most aggregate freight moves between inland quarries or wharves and urban areas for construction. Rapid logistics is an emerging freight market, typically using modified passenger trains to carry roll cages for parcels and other small logistics items into the heart of major urban areas.

5.2.20 Freight movements, like passenger services, are limited by factors including gauge, weight, speed and length of train. As freight end-to-end journeys often cross a number of railway geographical boundaries, freight movements can be complex to plan and deliver and require the full length of a journey to be operationally capable of handling a service. Available capacity and capability are also major considerations in end-to-end journey planning.

5.2.21 Freight trains are both electrically hauled using the 25kV overhead line and more commonly by diesel locomotives. There are around 850 locomotives in the UK with around 630 of these in operational service across the various freight operating companies. In 2018/19 rail freight services consumed 75 million kWh of electricity (an increase of 12.7% compared with 2017/18) and 153 million litres of diesel (a decrease of 6.7% compared with 2017/18)³⁶.

³⁵ Speech by Keith Williams at a Northern Powerhouse Partnership event. Available at <https://www.gov.uk/government/speeches/williams-rail-review-an-update-on-progress> .

³⁶ ORR, 2019, Rail Emissions 2018/19 Annual statistical release, p. 3.

- 5.2.22 Whilst a very small number of freight trains have either historically operated on, or remain able to operate on, the 750V DC third rail system its use for future freight operations remains unclear. High electrical current demand of freight trains and the availability of paths on these intensively used parts of the network would mean either significant investment in the third rail infrastructure or re-evaluation of service balance between passenger and freight in order for freight to utilise third rail traction more effectively.
- 5.2.23 Engineering trains, yellow plant (maintenance trains and equipment) and heritage stock also operate on the UK rail network. All three are challenging to decarbonise. Engineering trains and yellow plant often operate when the traction electrical supply is required to be switched off for engineering work meaning this is not a readily available traction source and alternative methods would be required. Work in this area is at an early stage and (whilst not addressed in this work) is being focused on as part of wider Network Rail research and development. Heritage operators using heritage steam and diesel traction almost all offer the opportunity for customers to offset emissions made.

NETWORK RAIL

5.2.24 Network Rail is the railway infrastructure owner for the railway in England, Scotland and Wales. The organisation is geographically split into five Regions: Scotland's Railway, Eastern, Southern, Wales and Western and North West and Central. The extent of each is shown in Figure 5 below.

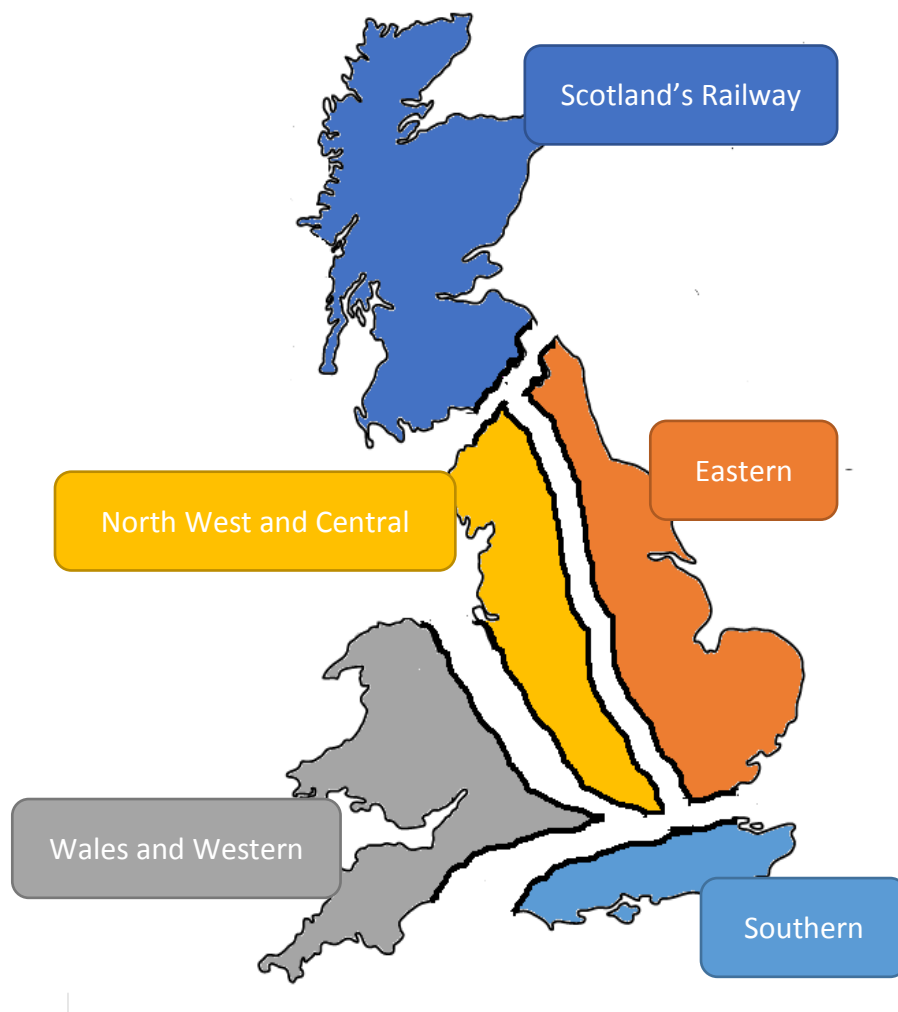

Figure 5: Network Rail Regions and their geographic extent

5.2.25 A more detailed description of the rail industry as a whole and the relationships between relevant groups and organisations within the industry, as well as the key changes potentially introduced as part of the Williams Rail Review, will be outlined in the TDNS Programme Business Case.

5.2.26 A summary of the key routes within each of the Network Rail Regions and the services which operate within them is outlined in Appendix 1.

NETWORK BASELINE

5.2.27 There are two main components of the network baseline. There is an infrastructure baseline and a rolling stock baseline. These are outlined in greater detail below.

INFRASTRUCTURE

5.2.28 The infrastructure baseline takes the currently electrified network as outlined in Table 1 as well as the committed electrification to be completed within Control Period 6 (not included in the numbers in Table 1). This includes:

- electrification of the Great Western Main Line (GWML) to Cardiff which was completed in December 2019; and
- electrification of the Midland Mainline to Market Harborough and Corby.

5.2.29 This work does not consider non-Network Rail infrastructure and as such does not include evaluation or appraisal for the following.

- **Core Valley Lines:** These transitioned in ownership on 28th March 2020 from Network Rail to the Welsh Government through their transport authority, Transport for Wales (TfW). TfW infrastructure has outlined proposals to partly electrify this infrastructure and operate electric/battery tram-train vehicles. For the purposes of the basecase it is assumed that this is a committed scheme.
- **East-West Rail:** Whilst East-West Rail will operate partly over Network Rail infrastructure the overall project is currently being developed and delivered by the East-West Railway Company. This is an arm's length body of the DfT. For the purposes of the TDNS basecase it is assumed that East-West Rail is a committed scheme. A further assumption has been made that it will be electrified to some extent using 25kV overhead line electrification, although this is not committed.
- **HS1:** The HS1 infrastructure, whilst operated under contract by Network Rail, is not Network Rail infrastructure and is thus not considered. The railway is electrified 25kV overhead line throughout.
- **HS2:** HS2 is a new high-speed railway being constructed between London, Birmingham and the North West and Leeds. The infrastructure is currently being developed and delivered by HS2 Ltd., an arm's length body of the DfT. The railway is planned to be electrified 25kV overhead line throughout. A number of potential new services operated on the conventional network as a result of HS2 would have to operate as diesel as the network stands today. These services have been considered within the TDNS economic appraisal.

5.2.30 Where possible all known committed infrastructure schemes which have a material impact on electrification have been considered as part of this appraisal.

5.2.31 The appraisal does not consider any committed infrastructure schemes such as new stations or revised track layouts which may have minor impacts on benefits or costs. The changes in these areas will be minor and will be within tolerance ranges of costs and benefits which are presented within this work.

ROLLING STOCK

5.2.32 A comprehensive rolling stock database exists which has been co-ordinated and agreed between Network Rail, RDG and RSSB as part of the industry Rolling Stock Strategy (RSS). The RSS reports produced to date categorise trains in seven key categories. These are outlined in Table 2 below.

Category	Description
A	Short distance self-powered diesel trains with 75 mph maximum speed
B	Middle Distance self-powered diesel trains with 100 mph capability
C	Long Distance Self-powered diesel trains with 125 mph capability
D	Electric trains with 75mph maximum speed
E	Electric trains with 100mph capability
F	Electric trains with 125mph capability
G	Very high-speed electric trains with 140mph+ capability
Locomotive – Freight	Locomotives used for freight services and shunting

Table 2: Current rolling stock categorisation used for UK rolling stock

5.2.33 Since this original classification bi-mode trains have been introduced in greater and greater numbers and new battery and hydrogen rolling stock is beginning to emerge. As a result, additional categories or redefinitions may be required.

5.2.34 Rolling stock types and operators have changed significantly over the past year with a number of new class types allowing for cascade of units and a number of unit types being retired as a result of Passengers of Reduced Mobility Technical Standard for Interoperability (PRM-TSI) legislation taking effect.

5.2.35 Appendix 2 provides a full list of rolling stock considered as part of this work and the operators at the time of analysis (Summer 2019 Timetable). This was the known

position at the time and a number of rolling stock moves and scrappages have occurred in the time since.

- 5.2.36 Of the freight vehicles identified the vast majority are Class 66 locomotives which make up around 60% of all locomotives in the UK.
- 5.2.37 For freight locomotives, whilst the majority of renewals are physically required for delivery over the next twenty to forty years, any new locomotive will require bespoke design in order to meet network restrictions, most notably around gauging.
- 5.2.38 In order to do this, freight operators will need to place an order, which will require a level of commitment from funders, who will wish to understand the likely long-term nature of the network and any associated risks. Once an order is placed it will likely take a period of three to five years before a test locomotive may enter service and then a period of time beyond that before large numbers enter operational service. Given these timescales, continued focus on improvements in diesel traction in the very short-term will be critical. This level of focus is also required for diesel passenger rolling stock in the shorter-term.
- 5.2.39 This means that a decision around the freight locomotive which will replace the existing (predominantly Class 66) fleet will need to begin research, design and development works within the next 12-24 months in order to meet the renewal timescales outlined here³⁷. The delivery of freight locomotives will play an integral part in determining the delivery programme for the recommendations made as part of this document. This will be outlined in the Programme Business Case to be provided in October 2020.
- 5.2.40 This means that it is critical that the locomotive manufacturers have a clear idea of what the UK rail network will look like from a traction point of view in order to be able to design and deliver locomotives to achieve carbon emissions targets.

NETWORK CAPACITY

- 5.2.41 The number of trains which can operate on the rail network is finite, with capacity governed by a number of operational factors. The available capacity varies from area to area depending on the characteristics of the railway and includes key factors such as: number of tracks, type of signalling system, linespeed, whether the railway is electrified or not and the relationship between capacity and performance of a given corridor.
- 5.2.42 Some areas of the rail network are approaching current capacity limits or are suffering performance degradation due to maximum capacity utilisation. Growth of

³⁷ Network Rail, TDNS Freight Workshop Summary Report, meeting held 24th January 2020.

rail use and changes in service provision from both a passenger and freight perspective over the past ten to fifteen years has until recently resulted in a number of overcrowded areas on the network especially around the UK's major cities. The extent to which this will remain is currently unclear given the impact that Covid-19 has had on transport usage, especially from a passenger perspective.

5.2.43 Any proposed future capacity enhancements to meet short to medium term capacity needs will need to be carefully considered in conjunction with infrastructure recommendations made as part of this work alongside the impacts that Covid-19 may have on future passenger and freight growth.

WORK TO DATE AND CURRENT PICTURE

5.2.44 Current work around rail decarbonisation has focused mostly around traction, as this is the largest contributor to the rail industry's overall emissions. The RSSB and other industry groups have undertaken a number of key research projects, which culminated in 2019 with two publications from the Rail Industry Decarbonisation Taskforce (RIDT)³⁸. The RIDT membership is drawn from representatives of major rail organisations to provide a comprehensive overview from the industry's various sectors. Its original remit was to answer the challenge from the UK government about how to remove diesel only trains from the network by 2040 and to develop an overall industry vision for decarbonisation.

5.2.45 The two published reports outlined that decarbonisation of the majority of passenger rail services is possible using a mix of further electrification, hydrogen and battery traction, but that to decarbonise long-distance-high-speed services and freight services requires significant further electrification³⁹.

5.2.46 Following a comprehensive review of which technologies would be sufficiently mature for traction decarbonisation within required time horizon, the RIDT concluded that the only technologies sufficiently advanced are trains powered from batteries, electric infrastructure and hydrogen⁴⁰. These three technologies as well as other potential methods of supporting and achieving decarbonisation are outlined in Section 5.6.

5.2.47 The RIDT subsequently concluded that the government would need to give clear, consistent and long-term policy signals to support the decarbonisation agenda as well as ensuring the industry structure and governance was established to allow

³⁸ RSSB, 2019, Rail Industry Decarbonisation Taskforce – Initial Report to the Rail Minister, and Rail Industry Decarbonisation Taskforce – Final Report to the Rail Minister.

³⁹ RSSB, 2019, Rail Industry Decarbonisation Taskforce – Final Report to the Rail Minister, p.10.

⁴⁰ RSSB, 2019, Rail Industry Decarbonisation Taskforce – Final Report to the Rail Minister, p.9.

incentives for decarbonisation to be implemented⁴¹. These recommendations were accepted by the Department for Transport.

NETWORK RAIL NON-TRACTION DECARBONISATION

5.2.48 Whilst this study is exclusively focused on traction decarbonisation, work is ongoing (led by Network Rail’s Technical Authority) to understand how Network Rail can decarbonise the non-traction elements of its business.

5.2.49 This workstream comprises a number of discrete projects delivered through the “Decarbonisation Programme”. The Decarbonisation Programme has seven main areas of focus, summarised in Figure 6 below.

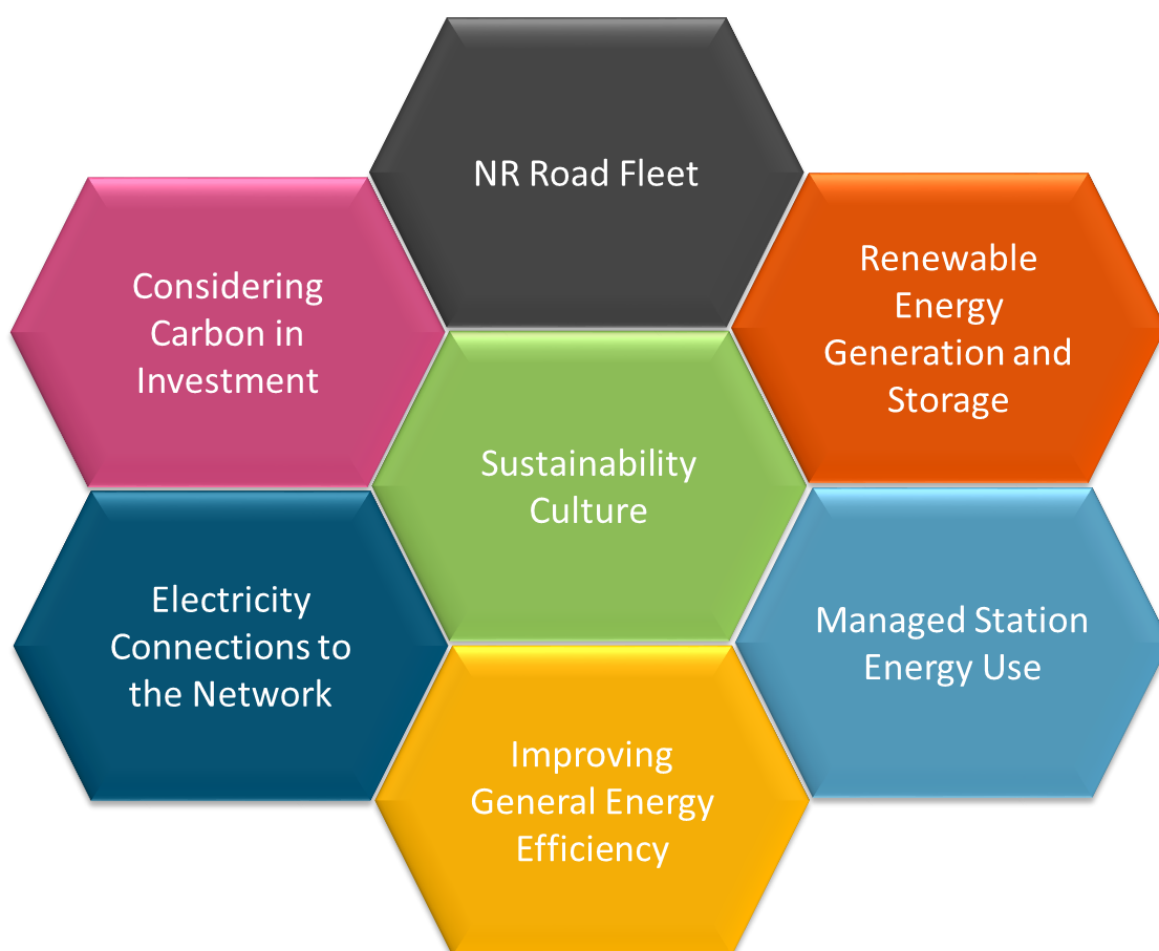

Figure 6: Summary of Network Rail “Decarbonisation Programme” themes

5.2.50 These workstreams and Network Rail’s commitments for 2025 and 2030 are outlined in greater detail in Appendix 3.

⁴¹ RSSB, 2019, Rail Industry Decarbonisation Taskforce – Final Report to the Rail Minister, p.5.

INTERNATIONAL DECARBONISATION EFFORTS

- 5.2.51 Due to the global focus on climate change and surface transport contributions to national emissions being significant, there has been a similar focus in a number of other European countries around the decarbonisation of transport.
- 5.2.52 Within Europe, the railway in Britain is comparable with the networks of France, Germany and Italy in terms of length and usage per capita. For a variety of reasons such as capacity increase, the extension of high-speed lines and, more recently, traction decarbonisation a number of major European countries have embarked on lengthy programmes of electrification, which have led to between 50-60% of their networks being operated with electric traction. A number have realised efficiency benefits due to the programme longevity⁴².
- 5.2.53 Similarly to the UK, most European countries' rail networks are relatively green modes of transport, contributing only a small proportion of national emissions⁴³. Switzerland⁴⁴ and Germany⁴⁵ are taking a similar approach to the UK with both publishing strategies around traction decarbonisation. Austria has also recently published a sustainability strategy which recommends a rolling programme of electrification to remove diesel train services⁴⁶. These strategies identify a mixture of further electrification and deployment of hydrogen and battery trains as solutions. Germany has become the first major European country to deploy hydrogen trains at scale (see Case Study 1 overleaf) alongside the commitment to deliver 5,000-6,000km of electrification in a rolling electrification programme⁴⁷.
- 5.2.54 The European Green Deal is part of the European Union's response to the Paris Climate Agreement. It proposes that a substantial part of inland freight carried by road today should shift onto rail and inland waterways to support the wider decarbonisation of transport⁴⁸. This will result in research and design investment in rail and rail freight which could be capitalised on if the UK were to follow a similar approach.

⁴² RIA, 2019, Electrification Cost Challenge, p.22.

⁴³ European Commission, 2020, 2021: The European Year of Rail – The European Green Deal, p. 1.

⁴⁴ SBB, 2020, Klimaneutrale SBB, (Note document is in German).

⁴⁵ DB, 2019, Alternativen zu Dieseltriebzügen im SPNV: Einschätzung der systemischen Potenziale, (Note document is in German).

⁴⁶ ÖBB, 2020, ÖBB Climate Protection Strategy 2030, p. 16.

⁴⁷ DB, 2019, Alternativen zu Dieseltriebzügen im SPNV: Einschätzung der systemischen Potenziale, (Note document is in German).

⁴⁸ European Commission, 2020, Decision of the European Parliament and of the Council on a European Year of Rail (2021), p.2.

Case Study 1 – Coradia iLint – Alstom’s Hydrogen Train

The iLint is special for its combination of different innovative elements: clean energy conversion, flexible energy storage in batteries, and smart management of traction power and available energy.



Specification

The train can carry **150 seated passengers and 150 standing passengers** and can achieve a range of up to **1,000km at a maximum speed of 140km/h**.

The **fuel cell and hydrogen fuel tank are placed on the roof** of the train while the lower portion of the train is fitted with the traction equipment and battery composition. The **hydrogen fuel cells supply power** and the **lithium-ion batteries are used for storage**.

Each iLint is equipped with two battery systems with a total capacity of 220 kWh. The **electrical energy generated during braking is temporarily stored** and then **released to the electric motors during acceleration**.

For hydrogen fuel supply, Alstom is currently working with partners to provide a permanent hydrogen infrastructure. This will include the potential to produce hydrogen locally and in a greener manner via electrolysis and wind energy. **Currently fuelling is undertaken by a mobile fuel tanker**.

Uptake

Two pre-production units have been in passenger service since September 2018 and have completed over 180,000km of total running. The first full order was for fourteen units which are currently being delivered. A further order of twenty-seven units has recently also been awarded in Germany. Recently trial operations have also been undertaken in The Netherlands

Information and Picture provided with permission from Alstom

5.3 CASE FOR CHANGE

- 5.3.1 This section sets out the key areas of the strategic case for decarbonisation of traction within the rail industry.
- 5.3.2 There are six key themes informing the case for change, the strategic objectives and the strategic benefits. The themes have been developed through structured workshops with representative teams from the rail industry, capturing thoughts and key aspects regarding decarbonisation of traction in the context of global, UK and rail industry emissions levels.
- 5.3.3 The six themes are depicted in Figure 7 below with the remainder of this section exploring, in detail, the case for change for each of the themes.



Figure 7: The six themes of traction decarbonisation

EMISSIONS REDUCTION – THE CASE FOR CHANGE

- 5.3.4 International policy surrounding climate change has been a major focus since the formation of the United Nations Framework Convention on Climate Change (UNFCCC) in 1992. Current emissions reduction pledges from the countries around the world would lead to warming of around 3°C by the end of this century⁴⁹. This is an

⁴⁹ Committee on Climate Change, 2019, Net Zero – The UK's contribution to stopping global warming, p. 13.

improvement from 2008 when the UK Climate Change Act was passed, when a forecast warming of 4°C was expected⁵⁰.

- 5.3.5 The Paris Climate Agreement was introduced in 2015 as an attempt to bring in the first fully global agreement to tackle climate change⁵¹. The principle of the Paris Agreement is to limit the increase in global average temperature to well below 2°C with efforts pursued to limit the rise to 1.5°C. This means that a significant increase in effort is required to improve the current climate commitments significantly⁵².
- 5.3.6 The agreement was the result of a long international negotiation process to agree an international climate framework for post 2020⁵³. The agreement came into force on the 4th November 2016 after fifty-five countries had ratified it (representing over 55% of global emissions)⁵⁴. The UK ratified the agreement on 17th November 2016 and by July 2020, 189 countries had ratified the agreement⁵⁵.
- 5.3.7 The Paris Agreement supports achieving the long-term temperature goal through a commitment to “global peaking of greenhouse gas emissions as soon as possible”⁵⁶. Whilst not explicit about an appropriate level of greenhouse gas emission it is generally assumed that this refers to net-zero greenhouse gas emissions at a global scale⁵⁷.
- 5.3.8 Net-zero UK emissions of long-lived greenhouse gases (most notably CO₂) would stop the domestic UK contribution to global temperature rise. A number of potential pathways exist to achieve net-zero emissions which subsequently contribute to different levels of warming to different degrees of confidence. The Committee on Climate Change report “Net-Zero: The UK’s Contribution to Stopping Global Warming” undertakes a comprehensive assessment of the Paris Agreement and identifies that for most 1.5°C pathways net-zero CO₂ emissions are reached around 2050 and by 2075 for well-below 2°C scenarios.
- 5.3.9 As such the report recommends that the UK should pursue an ambitious target to reduce greenhouse gas emissions to net-zero by 2050. Some national variations on this mean that it is proposed that Scotland should set a net-zero emissions target by 2045 and Wales should set a target of a 95% reduction from 1990 emissions levels by 2050. It concluded that only by setting a net-zero GHG target for 2050 will the UK

⁵⁰ Committee on Climate Change, 2019, Net Zero – The UK’s contribution to stopping global warming, p. 45

⁵¹ United Nations Framework Convention on Climate Change, 2015, Paris Agreement.

⁵² Committee on Climate Change, 2019, Net Zero – The UK’s contribution to stopping global warming, p. 11.

⁵³ UNFCCC, 2015, Paris Agreement.

⁵⁴ UNFCCC, Paris Agreement - Status of Ratification, available at: <https://unfccc.int/process/the-paris-agreement/status-of-ratification> .

⁵⁵ UNFCCC, Paris Agreement - Status of Ratification, available at: <https://unfccc.int/process/the-paris-agreement/status-of-ratification> .

⁵⁶ Committee on Climate Change, 2019, Net Zero – The UK’s contribution to stopping global warming, p. 70.

⁵⁷ Committee on Climate Change, 2019, Net Zero – The UK’s contribution to stopping global warming, p. 70.

deliver commitments made by ratifying the Paris Agreement. If the UK's ambition was replicated across the world, alongside ambitious near-term reductions in emissions, it would deliver a greater than 50% chance of limiting global average temperature increase of 1.5°C.

5.3.10 In response to this publication, the UK government announced on 27th June 2019 that it had signed legislation revising the previous emissions targets established under the Climate Change Act 2008 of an 80% reduction from 1990 GHG levels to net-zero greenhouse gas emissions by 2050.⁵⁸

SURFACE TRANSPORT DECARBONISATION – THE CASE FOR CHANGE

5.3.11 Rail is in a unique position within the surface transport sector, as it is the only practical transport mode capable of moving both people and heavy goods where there is a zero-carbon solution currently available. This means there is huge potential for the rail network to support decarbonisation of the surface transport sector as a whole, by shifting both passengers and goods to rail, where capacity, without impacting performance, exists to do so.

PASSENGER MODAL SHIFT

5.3.12 Whilst the uptake of electric and other ultra-low emissions vehicles is increasing across the UK, and hence decreasing the annual emissions share for cars and vans, the overall uptake remains a small percentage of total new vehicles⁵⁹. Uptake in general is limited by the provision of car charging infrastructure and the associated range anxiety this causes⁶⁰. More recently, issues have also been identified concerning the pace at which battery vehicles can physically be produced, with manufacturers having to limit production due to the availability of batteries and other key components⁶¹.

5.3.13 The passenger growth experienced in the rail sector over the past ten years has been significant⁶² but there is now uncertainty around future growth as a result of Covid-

⁵⁸ Department for Business, Energy and Industrial Strategy, 2019, UK becomes first major economy to pass net zero emissions law, available at: <https://www.gov.uk/government/news/uk-becomes-first-major-economy-to-pass-net-zero-emissions-law>.

⁵⁹ Society of Motor Manufacturers and Traders, Electric Vehicle and Alternatively fuelled vehicle registrations, available at: <https://www.smmmt.co.uk/vehicle-data/evs-and-afvs-registrations/>.

⁶⁰ Department for Transport, 2015, Uptake of Ultra Low Emissions Vehicles in the UK – A rapid Evidence Assessment for the DfT, p. 43.

⁶¹ Wired, News Article: As Electric Car sales soar, the industry faces a cobalt crisis, available at <https://www.wired.co.uk/article/cobalt-battery-evs-shortage>.

⁶² RDG, 2017, Partnership railway's transformation in numbers, p. 11.

19. Before the health outbreak and the subsequent restrictions this brought about on the use of public transport, long-term passenger growth forecasts showed continued growth⁶³. These figures did not include any further growth which may arise as a result of modal shift to rail for decarbonisation reasons.

5.3.14 Recent research on the impact of Covid-19 on climate change has indicated that there has been a reduction of 17% in daily global CO₂ emissions⁶⁴. The restrictions in travel and significant decrease in global car usage as a result of the restrictions imposed at the time to contain the spread of Covid-19 has allowed the extent to which car usage influences overall emissions to emerge. The research suggests that of the 17% reduction of CO₂ emissions realised on a global scale, just under half was attributable to journey reductions from road vehicles and shipping⁶⁵.

5.3.15 Rail network capacity limitations, which were outlined in section 5.2, mean that rail will only be able to accommodate a proportion of modal shift without significant capital investment beyond that outlined as part of the recommendations made as part of TDNS.

5.3.16 The Department for Transport's Transport Decarbonisation Plan has been established to explore the relevant usage and emissions of different transportation and provide clarity and strategic direction on how a greater balance between transport modes can be realised to reduce car emissions. Figure 8 overleaf shows the relative trips and distance share between the different modes of transport⁶⁶. As can be seen rail currently contributes around 2% of passenger trips and 9% of passenger distance.

⁶³ Network Rail, 2018, A better railway for a better Britain – Strategic Business Plan 2019-2024, p. 3.

⁶⁴ Le Quere et al, 2020, Temporary reduction in daily global CO₂ emissions during the Covid-19 forced confinement, Nature Climate Change, p.1.

⁶⁵ Le Quere et al, 2020, Temporary reduction in daily global CO₂ emissions during the Covid-19 forced confinement, Nature Climate Change, p.4 and p.8.

⁶⁶ Department for Transport, 2020, Decarbonising Transport – Setting the Challenge, p.17.

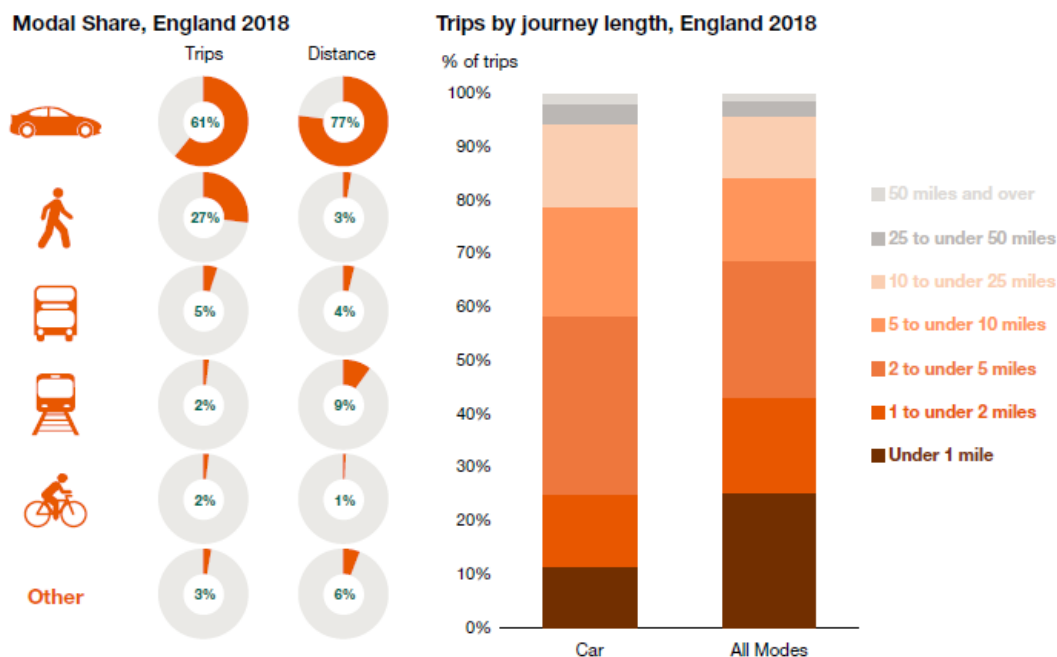

Figure 8: Average number of trips, per person, by trip purpose

MODAL SHIFT OF GOODS

5.3.17 Unlike the personal automotive sector there is currently no viable low-carbon solution for Heavy Goods Vehicles⁶⁷.

5.3.18 Current research suggests that HGVs powered by hydrogen and battery will be the likely solutions⁶⁸. The deployment of these vehicles will require research, development and investment in both the vehicles themselves and the refuelling and recharging infrastructure required for them to operate.

5.3.19 Whilst a potential solution is the deployment of road catenary with vehicles using pantographs to draw power, there is no known cost effective, practical application of this at scale. This is due to the significant infrastructure and vehicle costs associated with the extent to which infrastructure would be required, as well as the relative complexity of deploying catenary under bridges and through road tunnels to acceptable clearances⁶⁹. Whilst some of these factors are also issues for electrification in rail, there is greater understanding around their impacts as electrification has been deployed at scale within the rail industry. Alongside this, the extent to which rail is regulated and standardised reduces the issues of deployment

⁶⁷ National Infrastructure Commission, 2019, Better Delivery: The Challenge for Freight, p. 29.

⁶⁸ National Infrastructure Commission, 2019, Better Delivery: The Challenge for Freight, p. 9.

⁶⁹ Energy Systems Catapult, 2019, Decarbonising Road Freight, p. 45.

of widespread electrification and its operation compared with potential road applications.

5.3.20 Whilst commercial manufacture and deployment of both battery and hydrogen HGVs are likely to begin in the early 2020s it is unlikely the uptake of these will be significant until the 2030s⁷⁰. This makes the case for modal shift of freight to rail even stronger than that of passenger. Modal shift of freight from road to rail today can provide up to a 76% reduction in emissions⁷¹, which will only improve if this modal shift involves the use of electric traction.

5.3.21 Existing emissions data suggests that a 10% modal shift of HGV traffic to rail could reduce overall national emissions by almost as much as the whole rail industry contributes on an annual basis⁷². In a similar vein to passenger travel, capacity constraints will limit the amount of modal shift which could be achieved. The Department for Transport's Transport Decarbonisation Plan will be critical in defining the amount of modal shift which will need to be accommodated by rail.

PASSENGER AND FREIGHT END USER BENEFITS – THE CASE FOR CHANGE

5.3.22 The previous section reflected on the capacity constraints on the UK rail network that will limit the amount of modal shift which can be accommodated without significant capital investment. Capacity on certain corridors of the UK rail network is already approaching maximum levels. Rail passenger journeys have increased by almost 40% in the last 10 years⁷³ although the extent to which this will continue is unclear due to the ongoing Covid-19 crisis.

5.3.23 In the same time freight tonne kilometres hauled have decreased by around 16%, though this is principally driven by the loss of coal traffic as a result of the coal power plant closures outlined in Section 5.2⁷⁴. This overall decrease masks a number of key growth areas for freight in the last ten years, with construction traffic growing by 68% and intermodal traffic by 31%⁷⁵. As with passenger growth, the extent to which freight growth will continue is unclear due to the ongoing Covid-19 health crisis. Forecasts published from before the Covid-19 outbreak suggested passenger growth

⁷⁰ National Infrastructure Commission, 2019, Better Delivery: The Challenge for Freight, p. 30-31.

⁷¹ Department for Transport, 2016, Rail Freight Strategy, p. 6.

⁷² Department for Business, Energy and Industrial Strategy, 2019, Final UK greenhouse gas emissions national statistics: 1990-2017.

⁷³ ORR, 2019, Data Portal – Passenger Rail Usage Statistics.

⁷⁴ ORR, 2019, Data Portal – Freight Rail Usage Statistics.

⁷⁵ ORR, 2019, Data Portal – Freight Rail Usage Statistics.

could be up to 40%⁷⁶ by 2040 and freight tonne kilometres hauled potentially growing by over 90% by 2043⁷⁷; the extent to which these figures may be realised remains unclear at the present time. These figures do not, however, include any of the potential modal shift which may be required to support decarbonisation of the economy as outlined previously. An increase in capacity would be needed to accommodate both areas if this was to materialise. The DfT's Transport Decarbonisation Plan will explore the role of modal shift in further detail, outlining the extent of balance required between different transport modes.

5.3.24 As well as the required increase in capacity, in order to attract freight customers and passengers to rail, generalised journey times and generalised cost for rail would need to be broadly similar or better than existing road or air connections. For some areas this will mean journey times will need to be improved and cost efficiencies realised.

5.3.25 As the network becomes busier, unplanned disruption has greater impacts on freight customers and passengers. The ability to use diversionary routes is constrained by the infrastructure available, i.e. an electric powered train cannot use a non-electrified route, or a freight train cannot use an alternative route that is not gauge cleared. Diesel as a traction solution offers go anywhere capability for trains rather than relying on infrastructure.

5.3.26 The same is true for battery and hydrogen technology, although both technologies have capability limits such as range and maximum speed which will be outlined in section 5.6. For electrification, the provision of infrastructure is critical. Where electrification is provided the ability to have suitable diversionary routes in the event of both planned and unplanned disruption is essential. Continuity of service would need to play a key part in any decarbonisation proposals and services should not be made less resilient because of their reliance on infrastructure.

5.3.27 Changes in the frequency and intensity of weather events, coupled with some areas of aging electrification infrastructure, has meant that in some areas of the network performance delays associated with electrification issues have been increasing. Performance improvements to reduce the frequency, magnitude and impact of these events are a key focus for regional teams. Emerging evidence from CP5 electrification deployment using new standard series overhead line equipment is seeing greater levels of resilience to these events and subsequently having a significantly reduced impact.

5.3.28 Currently where planned or unplanned disruption occurs on routes which use electric traction, replacement diesel units are required, or the service will be reduced or

⁷⁶ Network Rail, 2018, A better railway for a better Britain – Strategic Business Plan 2019-2024, p. 3.

⁷⁷ Network Rail, 2019, Rail Freight Forecasts: Scenarios for 2033/34 and 2043/44, p. 5.

cancelled altogether. Clear and coherent response to planned and unplanned disruption is paramount to the attractiveness of the network for passengers and freight end users, as well as ensuring that future decarbonisation solutions have sufficient network resilience.

DIRECT RAIL – THE CASE FOR CHANGE

- 5.3.29 Decisions about replacement or augmentation of older diesel rolling stock will need to be made within the near term. Diesel trains in themselves have a significant number of moving parts, which require extensive and regular maintenance.
- 5.3.30 The majority of train operators currently run a mixed fleet (electric and diesel) meaning there is generally a lack of homogeneity within single operator’s fleets. This can often lead to multiplication of resources and inefficiency in spending due to the need to hold spares and train skilled resources for multiple different train types.
- 5.3.31 The railway as a whole system requires significant investment for continued operations maintenance and renewal. The committed funding to Network Rail to operate, maintain and renew the railway for Control Period Six (01st April 2019 to 31st March 2024) is £35 billion⁷⁸. Many more billions of pounds are spent annually by private companies on rolling stock and rail operations. Ensuring the railway is operated in a cost-efficient manner for taxpayers, passengers and customers is critical and any opportunities to realise efficiency should bring financial benefits.

ENVIRONMENTAL – CASE FOR CHANGE

- 5.3.32 Air quality is at the forefront of national, regional and local government agendas with a number of regional clean air or ultra-low emission zones in the process of being established to reduce NOx and particulate emissions⁷⁹. Whilst these currently do not directly apply to rail, if rail is seen as the principal source of emissions in sensitive urban areas this constitutes a key industry strategic risk. NOx emissions levels in some stations have previously exceeded acceptable legal limits⁸⁰ and research points to potential air quality issues for passengers on board diesel rolling stock⁸¹, driving the industry to respond and resolve the problem through operational and infrastructure solutions.

⁷⁸ ORR, 2018, Periodic Review 2018: Final Determination Summary of Conclusions, p. 2.

⁷⁹ British Vehicle Rental and Leasing Association (BVRLA), What are the clean air zones?, available at: <https://www.bvrla.co.uk/resource/CAZmap.html>

⁸⁰ Birmingham University, 2018, Evaluation of Air Quality at Birmingham New Street Station.

⁸¹ RSSB, 2020, Air Quality Strategic Framework, p. 21.

- 5.3.33 The air quality issue is different from the decarbonisation issue as it concerns different pollutants on a different scale. Decarbonisation is a global issue, with emissions made at a local level contributing to national and global emissions. Air quality issues are principally caused by Nitrogen Oxide (NOx) gases and particulate matter which are emitted from diesel engines as part of the internal combustion process. Unlike carbon emissions, the impact of these gases is more locally concentrated, especially in busier and more densely populated areas.
- 5.3.34 Air quality issues for rail are most significant in larger confined rail stations such as Birmingham New Street, Leeds, Manchester Piccadilly and others as well as other enclosed areas such as maintenance facilities. The RSSB, working closely with the wider rail industry, has recently published the rail industry Air Quality Strategic Framework. This publication provides a comprehensive overview of the impact of the air quality issue and the response required by the industry for both passenger and freight operations.

WIDER ECONOMY – THE CASE FOR CHANGE

- 5.3.35 The UK was one of the first nations to establish a net-zero legislative emissions target in response to the Paris Climate Agreement. As outlined earlier in this section, this will require all sectors of the economy to reduce emissions. This will require a significant amount of new infrastructure to be provided, including the deployment of new technologies and methodologies to reduce and eradicate emissions.
- 5.3.36 The cost of the UK achieving net zero by 2050 is estimated to be around 1-2% of GDP⁸². In order to successfully deliver this, both human and physical resources will be required in order to develop, design and deliver this infrastructure and the deployment of new technology.

CASE FOR CHANGE NOW

- 5.3.37 Whilst achieving a net-zero GHG emissions position by 2050 is needed to align with the Paris Climate Agreement targets, focus must be placed on removing as much CO₂ as possible as quickly as possible. At a global level if the 1.5°C target is to be achieved, total cumulative global emissions must be limited to around 420 billion tonnes of CO₂⁸³. Currently global emissions are around 42 billion tonnes each year⁸⁴.

⁸² Committee on Climate Change, 2019, Net Zero – The UK's contribution to stopping global warming, p. 27.

⁸³ IPCC, 2018, Special Report: Global Warming of 1.5°C – Chapter 2: Mitigation pathways compatible with 1.5°C in the context of sustainable development, p. 96.

⁸⁴ Carbon Brief, 2018, Analysis: Fossil-fuel emissions in 2018 increasing at fastest rate for seven years, available at <https://www.carbonbrief.org/analysis-fossil-fuel-emissions-in-2018-increasing-at-fastest-rate-for-seven-years>.

This means there is pressure to reduce emissions in the short-term if Paris Agreement targets are to be achieved.

- 5.3.38 From an overall economic perspective rail contributes less than 1% of the overall CO₂ emissions made by the UK economy as a whole⁸⁵. As this is the case, some would argue that investment in decarbonisation of rail does not yield optimal carbon reductions for money spent. However, rail is in a strong position to be able to offer solutions for supporting decarbonisation of the surface transport sector as a whole, especially for freight, through modal shift to rail.
- 5.3.39 If no action is taken to support decarbonisation of rail its percentage share of overall surface transport emissions will increase as other modes begin to decarbonise over time.
- 5.3.40 Furthermore, there will be sectors where achieving zero emissions will be difficult, if not impossible. The limited alternative technology availability for conventional air travel and the global market for aviation means that it is almost certain that aviation will be unable to achieve zero emissions by 2050⁸⁶. Agriculture is similarly a complex industry due to the emissions from fertilisers and livestock. Irrespective of whether changes in meat consumption reduces emissions from livestock there is still likely to be emissions from fertilisers due to an increase in intensive arable farming⁸⁷.
- 5.3.41 It is likely that a national approach will be taken to emissions offsetting, with the UK governments offsetting any residual emissions post 2050 from all sectors of the economy as a whole. The emissions budget available which can physically be offset will be dictated by the mixture and extent of natural and man-made carbon sequestration activities available.
- 5.3.42 Given indications from recent research it is unlikely that man-made carbon capture and storage techniques will be sufficiently advanced to sequester a significant volume of greenhouse gases⁸⁸. This means it is likely that many sectors of the economy will have to achieve zero or almost-zero emissions, as a majority of the post 2050 carbon emissions budget will be needed by aviation and agriculture⁸⁹. This means that surface transport as a whole, with rail as a component, will be likely to need to achieve zero or almost-zero emissions by 2050. The DfT's Transport Decarbonisation

⁸⁵ Department for Transport, 2020, Decarbonising Transport: Setting the Challenge, p. 11-12.

⁸⁶ The Royal Society, 2017, Decarbonising UK Energy: Effective technology and policy options for achieving a zero-carbon future, p. 3.

⁸⁷ The Royal Society, 2017, Decarbonising UK Energy: Effective technology and policy options for achieving a zero-carbon future, p. 3.

⁸⁸ UK FIRES, 2019, Absolute Zero, p.10.

⁸⁹ The Royal Society, 2017, Decarbonising UK Energy: Effective technology and policy options for achieving a zero-carbon future, p. 3.

Plan will outline the specific targets which will need to be achieved by each transport mode and provide a pathway for decarbonisation of transport.

5.3.43 The analysis provided as part of this document outlines a path to zero emissions from traction alongside the level of investment required to achieve this and ultimately (in the TDNS PBC) will provide a programme to deliver this. TDNS has also outlined a number of potential emissions reduction pathways. This suite of pathways will be critical in informing cross-modal and cross economic section decisions which will need to be made by UK Governments using a robust evidence base.

5.3.44 As well as the wider economic context there are a number of rail-specific factors supporting traction decarbonisation now.

- The long-term planning, development and delivery lead times associated with railway enhancements coupled with the significant volume of infrastructure and rolling stock required to achieve traction decarbonisation will mean that initiation needs to begin imminently if targets are to be achieved. Table 14 within the Commercial Case suggests that even if rail were only to achieve an 80% emissions reduction from traction an average of around 250 STKs of electrification per year would be needed.
- Recent electrification projects completed in the past five years, or currently being delivered, have developed knowledge and experience in electrification development and delivery. Delaying the start of further electrification will risk this experience being lost with subsequent delivery risk and cost impacts.
- There are several proof-of-concept vehicle designs which are ready to move into initial fleet deployment. Delaying their introduction risks loss of knowledge and experience in development, delivery and wider whole-system operational experience with potential downstream cost impacts.
- Rolling stock procurement and leasing is closely linked with renewal of franchises. Irrespective of potential changes from the Williams Rail Review there will be a need for operational specifications, likely including rolling stock fleet renewals. The opportunities to capitalise on these to deliver carbon efficiency is critical.
- A significant volume of the existing diesel emissions from rail traction come from diesel trains operating under already electrified infrastructure. The ability to use this existing infrastructure for electric traction would support decarbonisation. This is explored in greater detail in Section 5.6.

CASE FOR CHANGE SUMMARY

5.3.45 This section has outlined the key issues for each of the six themes identified as part of the strategic case for rail traction decarbonisation. The aspects explored are summarised in Figure 9 below.

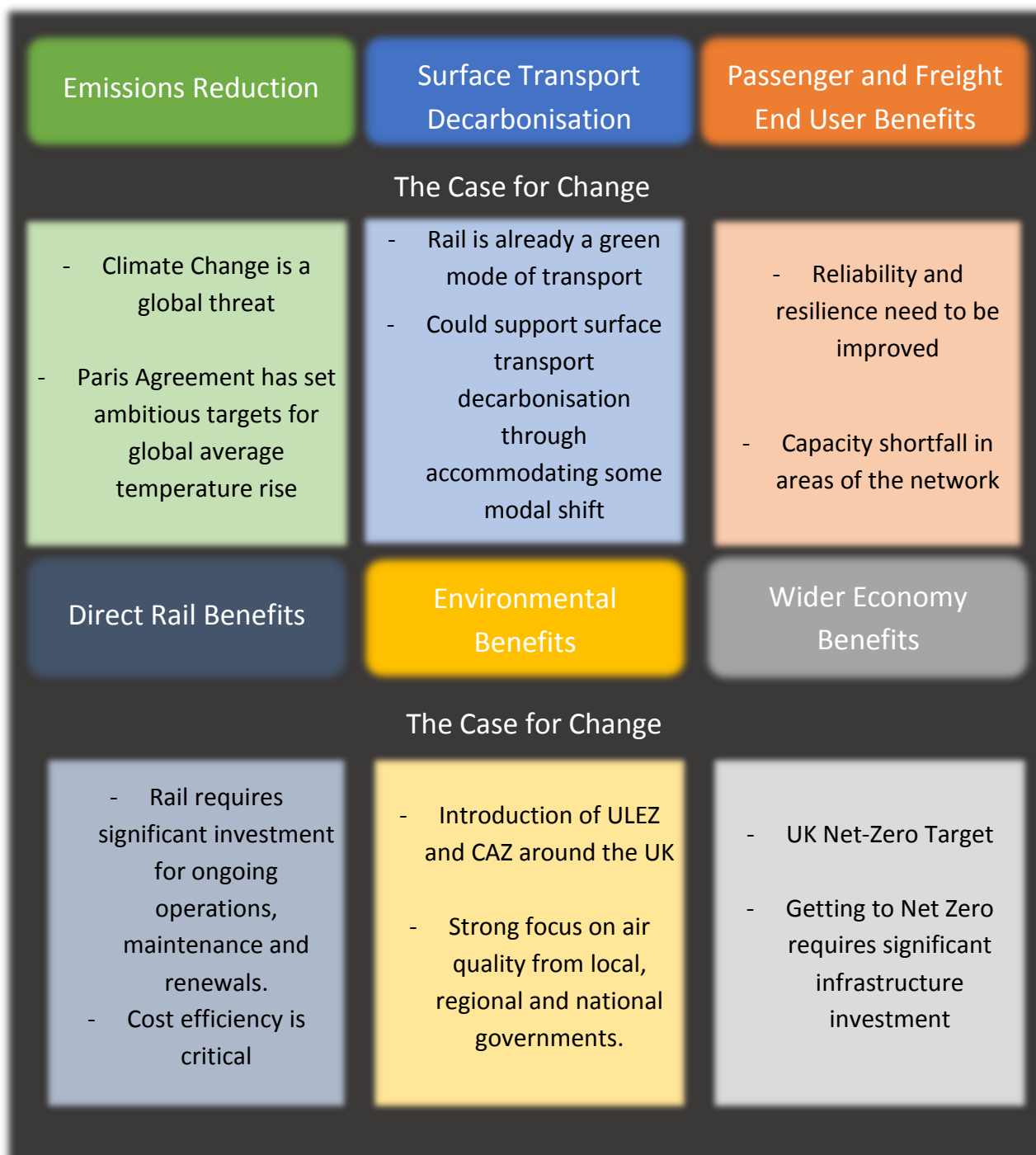

Figure 9: Summary of the Case for Change for traction decarbonisation

5.4 STRATEGIC OBJECTIVES

5.4.1 Following the case for change being made for each of the six themes, this section outlines the key strategic objectives which are required to be achieved for the six areas. This section outlines key targets and areas of focus in order to successfully resolve the issues outlined in the previous section.

EMISSIONS REDUCTION – STRATEGIC OBJECTIVES

5.4.2 The Case for Change clearly outlined the commitments made as part of the Paris Climate Agreement and the resulting requirements of the UK. The UK Government has revised the Climate Change Act 2008 legislation such that the target for the UK is now net-zero greenhouse gas emissions by 2050⁹⁰. Subsequent legislation passed to amend the Scottish Climate Change Act has established a net-zero target for Scotland by 2045⁹¹. As part of the Strategic Vision for Scottish Rail set out by Transport Scotland, a target of zero emissions for rail traction by 2035 has been established for Scotland’s domestic passenger services⁹². Welsh Government is aligned to deliver a 95% reduction in emissions from 1990 levels by 2050⁹³ and sees rail transportation as a critical element of combatting the current climate emergency⁹⁴.

5.4.3 Supplementing these wider national policies, the Rail Industry Decarbonisation Taskforce identified that it was possible to remove all diesel-only passenger trains from the network by 2040 with all diesel passenger trains removed completely by 2050⁹⁵. There is wide understanding of the challenge that this will pose to the freight community due to the high-power outputs required for freight operations. Both the RIDT final report and Committee on Climate Change reports recognise that there may be a residual diesel emission from rail freight post 2050 as a result⁹⁶.

5.4.4 Network Rail has recently approved a number of Science Based Targets for scope one, two (Network Rail operations) and three (Network Rail supply chain and traction energy) emissions. Network Rail’s scope one and two emissions account for a very small proportion of Network Rail’s total emissions with the vast majority being scope three. Within these scope three emissions, around two-thirds are imported

⁹⁰ UK Government, 2019, Climate Change Act 2008: Part 1 Carbon Target and Budgeting.

⁹¹ Scottish Government, 2019, Climate Change, (Emissions Reduction Targets) (Scotland) act 2019.

⁹² Transport Scotland, 2020, Rail Services decarbonisation action plan – pathway to 2035, p. 5.

⁹³ Welsh Government, Wales accepts Committee on Climate Change 95% emissions reduction target, press release available at <https://gov.wales/wales-accepts-committee-climate-change-95-emissions-reduction-target> .

⁹⁴ Welsh Government, 2019, A Railway for Wales: Meeting the needs of future generations, p. 5.

⁹⁵ RSSB, 2019, Rail Industry Decarbonisation Taskforce – Final Report to the Rail Minister, p.47.

⁹⁶ RSSB, 2019, Rail Industry Decarbonisation Taskforce – Final Report to the Rail Minister, p.52 and Committee on Climate Change, 2019, Net Zero – The UK’s contribution to stopping global warming, p. 145.

emissions from the Network Rail supply chain and just over a quarter are from rail traction.

- 5.4.5 Science-based targets aim to translate the amount of emissions reduction required globally to achieve the targets established as part of the Paris climate agreement to a corporate level. Once established, targets are submitted to the Science Based Targets initiative (SBTi) who act as administrators for all established science-based targets globally.
- 5.4.6 Network Rail in conjunction with Carbon Intelligence has used an SBTi approved methodology to establish an emissions reduction target for rail traction. In order for rail traction emissions to align with the Paris climate agreement target for well below 2°C a 27.5% reduction in emissions by 2029 from the baseline year of 2017/18 is required.
- 5.4.7 Table 3 below summarises the wider SBTi trajectory for traction emissions which would need to be achieved to align with Paris climate agreement targets.

To align with the well below 2°C target established as part of the Paris Climate Agreement traction emissions must reduce by...

15%	By the end of CP6 (2024)
27.5%	By the end of CP7 (2029)
40%	By the end of CP8 (2034)
52.5%	By the end of CP9 (2039)
65%	By the end of CP10 (2044)
77.5%	By the end of CP11 (2049)

Table 3: Science based targets for traction emissions reductions to achieve well below 2°C target

- 5.4.8 In England, in order to support decision making and advice at a more regional and local level, sub-national transport bodies (SNTBs) have been formed and are producing regional transport strategies. Appendix 4 summarises the key targets and aspirations of each of the transport bodies and any local authorities within them where transport emissions targets have been identified.

SURFACE TRANSPORT DECARBONISATION – STRATEGIC OBJECTIVES

- 5.4.9 Modal shift from road and air to rail (especially for freight) would support decarbonisation of transport in the short to medium term where capacity is available, without adversely affecting performance. Specific targets around modal shift will be identified as part of the DfT’s Transport Decarbonisation Plan.
- 5.4.10 The ability to provide further capacity on the network, in conjunction with journey time improvements and railway expansion through further investment, is critical to realise modal shift. Mega projects such as HS2, Northern Powerhouse Rail and East-West Rail have the opportunity to attract more people to the railway whilst simultaneously releasing additional capacity on the conventional network. Investment in freight enhancement schemes will be essential to accommodate not only the predicted forecast growth in the rail freight sector but further modal shift to rail.
- 5.4.11 Rail freight has played a critical part in the UK’s response to the Covid-19 health crisis, with the associated restrictions introduced underscoring the importance of rail freight in moving critical supplies for a number of sectors⁹⁷.
- 5.4.12 The Department for Transport’s Future of Freight and Transport Decarbonisation Plan will consider the need for modal shift and explore some of the policy decisions in these areas and outline key targets for all transport sectors.
- 5.4.13 The deployment of hydrogen energy at scale is likely to be needed for certain sectors of the economy to successfully decarbonise, most likely within both the industry and home heating sectors⁹⁸.
- 5.4.14 Whilst opportunities for application in transport are likely to be focused around shipping and HGVs there will be a significant role for hydrogen within the rail sector. Research conducted by the RSSB has identified commercial interest from industrial gas supply companies in supplying hydrogen for rail application due to the size and stability of the requirements over a significant period of time⁹⁹.
- 5.4.15 Hydrogen production today is mostly as a by-product of the chemical industry. Hydrogen fuel for use in rail in the future would ideally need to be produced locally to

⁹⁷ Network Rail, 2020, Coronavirus – how we have responded so far, available at: <https://www.networkrail.co.uk/stories/coronavirus-how-we-have-responded-so-far/>

⁹⁸ Hydrogen Taskforce, 2020, The Role of Hydrogen in Delivering Net Zero, p. 4.

⁹⁹ RSSB, 2020, Intelligent Power Solutions to Decarbonise Rail – Hydrogen Energy: Feasibility and Concept Design of Future Hydrail Enabled Railway Depots, p. 3.

the refuelling point due to the costs associated with transfer using a pipe network (unless suitable infrastructure already exists) and both the difficulty and associated carbon emissions of transportation by road¹⁰⁰. This would be achieved through the electrolysis of water using low-carbon electricity. It is estimated that a ten-train fleet of three car HMUs could require up to 3,000kg of hydrogen fuel each day, which is an order of magnitude greater than typical requirements for hydrogen bus fleets¹⁰¹. Indication of hydrogen fuel requirements as part of this work identifies that there is the potential for a significant and continual hydrogen fuel requirement in several areas across the UK.

5.4.16 With a number of transport modes exploring the opportunities of using hydrogen including buses, vans, HGVs and cars¹⁰² the potential demand from multiple vehicle groups as well as trains could increase this hydrogen demand further. Due to the combined nature of transport systems (i.e. road and rail often being close to each other) opportunities exist to provide combined fuelling stations, potentially leading to economies of scale for hydrogen manufacture and distribution, resulting in improved cost effectiveness of hydrogen for a number of sectors. This could equally apply to battery recharging hubs.

PASSENGER AND FREIGHT END USER BENEFITS – STRATEGIC OBJECTIVES

5.4.17 As outlined in section 5.3, whilst there is at present uncertainty about passenger and freight growth, pre-Covid-19 forecasts indicated significant growth for both groups up to 2040. Both this growth and the potential need to accommodate modal shift to support the wider decarbonisation of transport will mean more capacity is required. The levels to which rail will be required to support modal shift will be outlined in the DfT's Transport Decarbonisation Plan.

5.4.18 Greater use of electric and alternative traction in its own right provides the opportunity to improve train speeds and acceleration, provide new rolling stock with higher comfort levels, as well as providing longer trains and the ability to haul heavier freight loads. These factors combined mean that provision of traction decarbonisation could unlock latent capacity and improve overall journey times for both passengers and goods, supporting overall demand for rail transport.

¹⁰⁰ RSSB, 2020, Intelligent Power Solutions to Decarbonise Rail – Hydrogen Energy: Feasibility and Concept Design of Future Hydrail Enabled Railway Depots, p. 2.

¹⁰¹ RSSB, 2020, Intelligent Power Solutions to Decarbonise Rail – Hydrogen Energy: Feasibility and Concept Design of Future Hydrail Enabled Railway Depots, p. 2.

¹⁰² European Commission, Mobility and Transport: Hydrogen Fuel cells for transport, available at: https://ec.europa.eu/transport/themes/urban/vehicles/road/hydrogen_en .

5.4.19 Reliability and resilience are key priorities for passengers and freight end users. Providing this will rely on establishing key diversionary routes which can be seamlessly used regardless of traction technology adopted.

DIRECT RAIL – STRATEGIC OBJECTIVES

5.4.20 Delivery of cost-efficient operations of the railway is a key objective. For decarbonisation a key consideration is that for any future rolling stock purchase (regardless of traction type), the incremental whole life cost must be understood.

ENVIRONMENTAL – STRATEGIC OBJECTIVES

5.4.21 Strong national and regional focus is being placed on air quality issues as outlined in section 5.3 and the rail industry Air Quality Strategic Framework¹⁰³. This means rapid action is required and the recommendations made as part of this traction decarbonisation work will not be delivered in sufficient time to rectify the air quality challenges being faced.

5.4.22 However, traction decarbonisation has the potential to provide a longer-term solution to air quality issues from both passenger and freight operations as well as the environments surrounding the railway.

5.4.23 The ability to provide a longer-term solution and when this will be achieved may influence the short-term decisions being made to rectify air quality. The ability to provide a longer-term solution is a key strategic objective of traction decarbonisation in order to ensure short-term solutions proposed as part of the rail industry Air Quality Strategic Framework and decarbonisation solutions are complementary.

WIDER ECONOMY – STRATEGIC OBJECTIVES

5.4.24 Traction decarbonisation will require significant investment in infrastructure and rolling stock. The opportunities this provides for wider long-term high-quality job creation to develop, design and deliver this are significant.

5.4.25 Given the geographical nature of the rail network and the majority of the unelectrified network being found in the South West, Wales, the Midlands, the North and Scotland these job opportunities are likely to be away from London and the South East.

5.4.26 Hydrogen traction technology is in its infancy around the world. This section has already outlined the critical need for hydrogen power in certain sectors of the

¹⁰³ RSSB, 2020, Air Quality Strategic Framework.

economy. Opportunities to introduce hydrogen powered rolling stock within the UK rail network are at an advanced stage with significant technological research and development having been undertaken. There is a possibility for rail to be an early adopter of hydrogen technology in the UK and play a key part in supporting the establishment of the wider UK hydrogen economy.

5.4.27 The work completed to date on hydrogen traction and early deployment of the technology in rail could support and inform other sectors of the economy as they begin to develop and deliver hydrogen-based solutions for decarbonisation in the longer-term.

STRATEGIC OBJECTIVES SUMMARY

5.4.28 This section has outlined the key objectives for each of the six themes identified as part of the strategic case for rail traction decarbonisation. The aspects explored are summarised in Figure 10 below.



Figure 10: Summary of the Strategic Objectives for traction decarbonisation

5.5 STRATEGIC BENEFITS

5.5.1 Following the case for change being made and the strategic objectives outlined for each of the six themes, this section summarises the key strategic benefits which could be realised as a result of traction decarbonisation. The section concludes by defining which of these benefits will be considered in the economic analysis contained within the Economic Case.

EMISSIONS REDUCTION – STRATEGIC BENEFITS

5.5.2 There are two main strategic benefits associated with the emissions reduction theme:

- long-term carbon emissions reduction; and
- carbon emission reduction through cascade of most carbon-efficient, compliant Diesel Multiple Units (DMU) as these are displaced by alternative traction.

There are explored in greater detail below.

LONG-TERM EMISSIONS REDUCTION

5.5.3 Ultimately the aim of traction decarbonisation is to end the contribution of GHG emissions from rail traction.

5.5.4 The extent to which traction emissions contributes to overall UK emissions is relatively small; the challenges that will be faced in the aviation and agriculture sectors will mean that all other sectors are likely to be required to reach zero or near zero emissions. The DfT's Transport Decarbonisation Plan will outline the specific targets for rail as well as other transport sectors.

5.5.5 As outlined in the Committee on Climate Change report, in order for the UK to support the Paris Agreement it must end its contribution to global CO₂ emissions¹⁰⁴.

DIESEL MULTIPLE UNIT CASCADE

5.5.6 The age of diesel trains varies significantly, from the brand-new Class 195, 196 and 197 units currently being introduced to the early Class 150 and 153 units which were introduced in the mid-1980s.

5.5.7 Diesel engine technology has moved on significantly in the last fifty years with diesel engines provided today required to meet much higher standards with regard to NOx

¹⁰⁴ Committee on Climate Change, 2019, Net Zero – The UK's contribution to stopping global warming

and particulate emissions. Whilst diesel engines will never be “green”, the relative CO₂ emissions rates between rolling stock can differ.

- 5.5.8 As more and more of the UK rail network becomes decarbonised through electrification and deployment of battery and hydrogen rolling stock this will displace diesel trains. These trains may still have operational life and may be more emissions efficient than other diesel trains on the network. Utilising these trains to remove those with higher emissions rates will support with achieving interim emissions targets between now and 2050.
- 5.5.9 Cascade of these more efficient compliant diesel trains may also provide the opportunity to improve capacity in the short-term in some areas through providing longer trains, potentially alleviating some of the capacity constraints preventing modal shift as outlined in sections 5.3 and 5.4.
- 5.5.10 Interim emissions targets as outlined in Table 3 will require the support of an optimum emissions deployment for compliant diesel units currently in operation ensuring the higher polluting, higher emissions trains are prioritised for removal.
- 5.5.11 Hybridisation of diesel units can improve fuel efficiency and subsequently reduce emissions as well as utilising the full asset life of newer diesel traction. This could also support achieving interim emissions targets outlined in Table 3.
- 5.5.12 The opportunity to cascade diesel/electric bi-mode trains will also be critical as the network becomes progressively more electrified. As areas of the network begin to be able to operate services with straight electric multiple units (EMUs), battery multiple units (BMUs) and hydrogen multiple units (HMUs), where services were previously operated by diesel/electric bi-modes these bi-modes could be cascaded to other areas to optimise use of existing and new electrified infrastructure.

SURFACE TRANSPORT DECARBONISATION – STRATEGIC BENEFITS

5.5.13 There are four main strategic benefits associated with the surface transport decarbonisation theme:

- passenger safety improvements;
- decreases in road maintenance costs;
- decreases in road congestion; and
- economies of scale in hydrogen deployment.

There are explored in greater detail below.

PASSENGER SAFETY IMPROVEMENTS ON ROAD

5.5.14 Rail is one of the safest modes of transport in Europe¹⁰⁵, and is significantly safer than the road network, especially where deaths per passenger kilometre are considered. The majority of fatalities occur on motorways and major A-roads, with HGVs accounting for between three and five times more accidents than other vehicles¹⁰⁶. On the UK road network there are more than four deaths per million passenger kilometres in motor vehicles every year¹⁰⁷.

5.5.15 Modal shift to rail of both passengers and goods has been outlined as a key objective to achieve decarbonisation of the wider surface transport sector. As a secondary benefit, passengers and goods are being moved to a safer mode of transport. This benefit is especially pronounced for freight, with a single freight train removing up to 76 HGVs from the road¹⁰⁸.

DECREASE IN ROAD MAINTENANCE COSTS

5.5.16 If active modal shift to rail did occur this would subsequently reduce the number of vehicles on the road and potentially allow for a reduction in the volume of road maintenance required.

5.5.17 This could bring significant financial benefits to road infrastructure owners and local authorities. The modal shift of freight is likely to be of greater significance than passengers as freight modal shift removes a large number of HGVs per train, with HGVs causing greater impacts to road maintenance than cars and other small road vehicles¹⁰⁹.

DECREASES IN ROAD CONGESTION

5.5.18 Modal shift to rail also provides a benefit in the form of road decongestion. A number of the UK's roads, especially major motorways and A-roads are at, or approaching, congested status at a number of points in the day¹¹⁰. This can cause significant impact on journey times for both passenger and freight along key corridors.

5.5.19 Providing a modal transfer to rail could allow a number of the key congestion hot-spots to be relieved. In a similar vein to safety and road maintenance, modal shift of

¹⁰⁵ European Commission, 2020, 2021: The European Year of Rail – The European Green Deal, p. 1.

¹⁰⁶ Better Transport, 2017, HGV fatal collision rates, p. 4.

¹⁰⁷ Department for Transport, 2019, Passenger casualty rates for different modes of travel (RAS53).

¹⁰⁸ Network Rail, 2013, The Value and Importance of Rail Freight, p. 4.

¹⁰⁹ Network Rail, 2013, The Value and Importance of Rail Freight, p. 4.

¹¹⁰ Department for Transport, 2020, Road congestion and travel times statistics.

freight from road to rail could significantly reduce congestion due to the number of lorries removed for each freight train operated.

5.5.20 Recent work undertaken by Network Rail as part of the development of a programme business case for the Felixstowe to the Midlands and North (F2MN) corridor suggests that for each additional daily train path provided to and from Felixstowe, around 14,600 single lorry journeys would be removed from the roads per annum. If these benefits were realised then the number of lorry miles would be reduced by over three million per annum, based on an average distance of 210 miles. This would result in socio-economic benefits of £2.8m per annum, reflecting road de-congestion benefits, environmental benefits (reduced carbon emissions and reduced noise and air pollution) and safety benefits¹¹¹.

CROSS MODAL TRANSPORT ECONOMIES OF SCALE

5.5.21 Provision of hydrogen and battery powered rolling stock has the potential to both provide support to and receive benefits from co-ordinated transport refuelling and recharging hubs.

5.5.22 Hydrogen is currently being actively considered in a number of surface transport sectors, with significant deployment already found in buses and trials of cars and HGVs emerging. Manufacture and provision of hydrogen refuelling in railway facilities to refuel trains could support these other transport sectors and vice versa, especially given the scale of refuelling likely to be required for rail traction.

5.5.23 Provision of infrastructure for battery charging of trains at terminus stations could be used to provide charging facilities for cars and taxis using station car parks and taxi ranks or for electric buses at railway station bus stands where rail and other modes create a transport hub.

5.5.24 Providing combined recharging and refuelling facilities could be relatively straightforward as railway depot facilities are often sited in developed urban areas with road access, and nearly all stations have road access, parking facilities, taxi ranks or bus stops where provision of combined battery charging could be beneficial.

5.5.25 Approaching the provision of hydrogen and battery recharging in this way could decrease overall hydrogen fuel costs and battery charging infrastructure costs significantly and allow overall costs to be shared between several sectors, with greater confidence in levels of demand.

¹¹¹ Network Rail, 2020, Felixstowe to the Midlands and North Programme Business Case.

PASSENGER AND FREIGHT END USER BENEFITS – STRATEGIC BENEFITS

5.5.26 There are three main strategic benefits associated with the passenger and freight end user benefits theme:

- journey time reduction and potential capacity increase;
- improved reliability and resilience; and
- improved passenger experience.

These are explored in greater detail below.

JOURNEY TIME REDUCTION AND POSSIBLE CAPACITY INCREASE

PASSENGER TRAINS

5.5.27 In general, all alternative traction trains have superior acceleration when compared with diesel equivalents, which could potentially deliver reduced journey times, particularly on routes with closely spaced stations where improved acceleration and deceleration give proportionately large decreases in journey time.

5.5.28 In addition, an improved power to weight ratio in trains could deliver significantly reduced journey times on routes with steep gradients. Where this ratio is made worse due to increased axle loading, there may be a negative impact on journey times.

5.5.29 Work undertaken by Network Rail's Design Delivery (NRDD) organisation modelling the performance of alternative powered rolling stock compared with diesel traction has identified the journey time saving opportunity can be up to 7% for services with frequent stops¹¹². Whilst the opportunity for services which do not have as regular start-stop patterns is not as high, journey time improvements of up to 2% could still be achieved compared with diesel traction¹¹³.

FREIGHT TRAINS

5.5.30 The Rail Industry Decarbonisation Taskforce final report identified that, of existing technology, only electrification can be deployed in order to decarbonise the rail freight sector¹¹⁴. Due to operational considerations limiting the amount of electrification possible into freight yards, terminals and ports a secondary traction

¹¹² Network Rail NRDD, 2020, TDNS Capacity Modelling Study p.13.

¹¹³ Network Rail NRDD, 2020, TDNS Capacity Modelling Study p.13.

¹¹⁴ RSSB, 2019, Rail Industry Decarbonisation Taskforce – Final Report to the Rail Minister, p.10.

mode or local shunting move using a battery powered shunter will be required. This is explored in greater detail in Section 5.6.

5.5.31 There is a clear difference in the haulage capability (with regard to power to weight ratio) between diesel and AC electric freight traction which offers the potential for the following.

- Substantially greater trailing weight, hence permitting increased freight tonne capacity without need to increase number of paths. Capacity modelling has indicated that, from a traction perspective, up to 87% greater tonnage could be hauled by an electric locomotive whilst still maintaining diesel timings¹¹⁵.
- Journey time reduction and capacity benefits of electric freight traction. Capacity modelling has indicated journey reductions of up to 12% are possible for trains up to 2000 tonnes. For the heaviest loaded trains currently on the network, such as those from the Mendip quarries, journey time improvements of 23% were modelled¹¹⁶.

5.5.32 These benefits are not included in the TDNS economic analysis but will need to be incorporated in bottom-up development for projects and programmes arising from TDNS.

5.5.33 The potential reduction in journey time could require fewer trains to be run and fewer locomotives for the Freight Operating Company (FOC) to acquire and operate or allow more efficient use of a fleet. This benefit is likely to be particularly strong on routes with steep gradients and where a route is particularly busy there may be the potential to release paths for additional freight or passenger services.

5.5.34 Compared with passenger services, FOCs are more likely to operate services which involve one or more changes of locomotive when transferring between electrified and non-electrified sections of route or more commonly simply run a diesel locomotive under the wires for substantial distances to mitigate against the need for multiple locomotives.

5.5.35 Extending the electrified network would reduce the requirement for locomotive changes and increase the number of possible freight journeys made by electric locomotives. This would subsequently shorten journey times, reducing resource requirements and allowing improvements in overall operation.

5.5.36 In the context of wider network optimisation and capacity maximisation, electrification could also support potential forecast growth at UK ports and inland

¹¹⁵ Network Rail NRDD, 2020, TDNS Capacity Modelling Study p. 15.

¹¹⁶ Network Rail NRDD, 2020, TDNS Capacity Modelling Study p.14.

freight distribution facilities. This could avoid the routing of additional trains through congested electrified routes such as the West Coast and East Coast Main Lines.

- 5.5.37 Reduced journey times for freight trains mean they can fit better with the relative passenger train speed profile. This means that freight trains may not need to be held in loops as often in order to allow passenger services to overtake. This also potentially avoids the need for the construction of loops and the associated infrastructure cost.
- 5.5.38 Furthermore, the possibility of increasing tractive loads on freight trains becomes feasible whilst keeping timings of existing train paths. This could significantly increase the freight tonnes hauled nationally without needing to increase the number of trains or paths used to haul these heavier loads. As outlined, indicative capacity modelling suggests up to an 87% increase could be accommodated on a single train, though other constraints such as train length and infrastructure weight restrictions would likely limit such an increase in most cases¹¹⁷ (i.e. the power output of a freight locomotive is no longer the limiting factor for increasing length or weight of freight trains).
- 5.5.39 The capacity analysis work identified that a consist in line with existing operating length parameters could achieve a 20% load increase whilst achieving a 10% journey time improvement.
- 5.5.40 Finally, introduction of electrification for the UK rail freight sector would make rail a potential zero-carbon freight transportation solution available for the wider UK logistics sector. As noted in previous sections there are currently no credible zero-emissions solutions for heavy freight in the other transport sectors (road, air and sea) and this is likely to be the case for a number of years.

IMPROVED RELIABILITY AND RESILIENCE

- 5.5.41 Access for engineering works often requires closure of sections of route for several weekends (or overnight periods). As well as this the railway can suffer from unplanned disruption from events such as trespass or weather-related incidents such as flooding or debris blocking the railway. These weather-related disruptions are increasing in number due to the effects of climate change in the UK¹¹⁸.
- 5.5.42 During times of disruption trains may be cancelled, replaced by buses or diverted onto longer alternative routes where these are available. Journey times can be extended further in instances where a route is normally operated by electric traction but transferred onto an unelectrified diversionary route requiring a stop to allow a

¹¹⁷ Network Rail NRDD, 2020, TDNS Capacity Modelling Study p. 15.

¹¹⁸ Network Rail, 2017, Weather Resilience and Climate Change Adaptation Strategy 2017-2019, p. 3.

diesel locomotive to be attached, or passengers transferred to a diesel unit or rail replacement bus service.

5.5.43 A concerted effort by the rail industry has realised a reduction in use of rail replacement bus services, which tend to be slower and are likely to be perceived as offering a poorer quality of service, as well as often not being a zero-carbon solution in themselves and struggling to match the same accessibility standards as rail.

5.5.44 Electrification of key diversionary routes and/or provision of alternative traction on existing routes provides a means to avoid these issues. There are several potential benefits which could be realised.

- Ability to reduce journey times by avoiding the need for changes of rolling stock and allowing the use of higher performing rolling stock on the diversionary route.
- A reduction in the costs associated with providing alternative non-electric traction (including buses), and a reduction in the overall number of vehicles required as journey times are reduced.
- A potential increase in passenger satisfaction and revenue associated with the perceived quality of service, particularly where trains would otherwise be replaced by buses.
- Performance benefits in the event of unplanned disruption to the 'core' route, as trains can easily be rerouted without the need for procurement of alternative traction at short notice.
- Increased network resilience to services when unplanned disruption or perturbation occurs, ensuring passenger and freight end user journey impacts are reduced as far as possible.

5.5.45 The extent to which these benefits would be justified by the infrastructure cost required would depend on the level of traffic carried by the core route and the relative cost of alternative approaches. The diversionary route would also need to be cleared to a gauge equivalent to the core route.

5.5.46 Given the infrequency of diversions it is unlikely that a case for electrification could be made on the basis of diversionary benefits alone, but this could represent an additional benefit beyond the conversion of regular traffic in certain areas.

5.5.47 Diversionary routes are particularly important for electric freight services where the opportunity does not exist to transfer onto alternative replacement transport. FOCs

consider the provision of diversionary routes as being a fundamental requirement for investment in electric traction¹¹⁹.

PASSENGER EXPERIENCE BENEFITS

5.5.48 Diesel trains often produce a significant amount of on-train noise due to the process of combustion of diesel in the engines.

5.5.49 All of the alternative traction types offer a marked improvement through the removal of diesel combustion. Furthermore, due to the unit configurations of all three alternative traction types there is opportunity to provide longer trains compared with diesel services, thus increasing passenger capacity and seat numbers without requiring additional trains and train paths. This may require infrastructure modification such as platform lengthening in some locations.

DIRECT RAIL – STRATEGIC BENEFITS

5.5.50 There are five main strategic benefits associated with the direct rail theme:

- rolling stock initial capital cost;
- track maintenance costs;
- ongoing operating costs;
- rolling stock maintenance costs; and
- safety.

These are explored in greater detail below.

ROLLING STOCK INITIAL CAPITAL COST

5.5.51 Trains with alternative traction power other than diesel have a broadly similar or lower initial capital cost to diesel depending on the traction solution used. Due to multiple traction systems this will not be the case for bi-mode and tri-mode units.

5.5.52 Extensive consultation with the wider industry, including with train manufactures and ROSCOs, as well as previous modelling work undertaken by RSSB through T1145, has supported in providing assumptions around rolling stock. The overall cost differences between diesel and alternative traction types are to an extent uncertain, but it is anticipated that the cost of new-build stock will be comparable with diesel for hydrogen and battery rolling stock and up to 30% lower for electric rolling stock.

¹¹⁹ Network Rail, TDNS Freight Workshop Summary Report, meeting held 24th January 2020.

TRACK MAINTENANCE COSTS

- 5.5.53 Alternative traction modes have the potential to have both a positive and negative impact on infrastructure operating costs as this is strongly correlated with rolling stock weight.
- 5.5.54 Electric Multiple Units (EMUs) are typically lighter and have a lower axle load than diesel, battery, hydrogen and bi-mode vehicles, which are required to carry their own power sources. A reduced axle load translates into reduced track wear and tear and reduced infrastructure renewal frequency. Where savings compared with existing fleets exist these are passed on to train operators in the form of lower variable track access charges (VTAC).

ONGOING OPERATING COSTS

- 5.5.55 Analysis has identified that vehicles which draw power from the electric grid are significantly less expensive to run than those which use diesel.
- 5.5.56 Both electric and battery powered rolling stock have the potential to reduce overall fuel costs. Whilst the per km fuel cost of hydrogen is currently significantly higher than that of red diesel this is largely driven by the cost of electricity, but this cost differential could be offset by a number of factors¹²⁰. Equally as increased volumes of hydrogen fuel are provided within both rail and the wider economy the overall cost of hydrogen is likely to decrease.

ROLLING STOCK MAINTENANCE COSTS

- 5.5.57 Diesel trains have a significant number of moving parts which require extensive and regular maintenance. Alternative traction types largely provide greater simplicity of the equipment required to provide traction. Greater simplicity results in reduced downtime, a reduced need for depot stabling and reduction in storage of spares. This may not be the case with bi-mode and tri-mode vehicles as they have greater complexity.
- 5.5.58 Fourteen out of the twenty-two passenger train operators currently run a mixed fleet (electric and diesel) meaning there is not homogeneity within operators' fleets. Changing tractive type to allow a greater degree of homogeneity in operators' fleets could result in savings in depot operational costs and other aspects such as staff training.

¹²⁰ RSSB, 2020, Intelligent Power Solutions to Decarbonise Rail – Hydrogen Energy: Feasibility and Concept Design of Future Hydrail Enabled Railway Depots, p. 56.

SAFETY

5.5.59 Whilst there are likely to be few direct safety differences between traction technologies, there are a number of areas where deployment of technologies in order to decarbonise could impact on overall system safety. These areas are outlined below.

HEALTH ISSUES ASSOCIATED WITH DIESEL FUMES

5.5.60 The environmental benefits section below outlines a number of key aspects where improving air quality will bring significant benefits to staff. Whilst air quality improvements are required in a significantly shorter timescale than decarbonisation deployment of traction decarbonisation will provide a permanent long-term solution to staff exposure to diesel fumes.

INCREASES IN SAFETY RISK

5.5.61 Whilst not a new risk, deployment of significant volumes of electrification infrastructure will increase the potential for operations and maintenance staff to come into contact with live equipment.

5.5.62 Network Rail has extensive safety management procedures in place to prevent this from happening but with significant volumes of electrification the potential for occurrence does increase.

5.5.63 The same risk is equally increased for trespassers onto the railway. Whilst safety education programmes such as those seen recently on Midland Main Line are considered best practice (see case study 2 below), the increase in electrified lines does increase the potential for serious incidents.

Case Study 2 – Midland Mainline Electrification Education Programme

As part of the electrification of the Midland Mainline from Bedford to Kettering and Corby Network Rail undertook an education programme called “Always On. So Always Stay Off”.

The programme laid out to dangers, facts and fiction around electric infrastructure to make people who may never have experienced it aware of its dangers.

The education programme run as part of the electrification programme focused on a number of key groups who use and access the railway.

ELECTRIFIED LINES ARE

ALWAYS ON.

SO ALWAYS STAY OFF.

Young People in schools were taught about the dangers of trespass and contact with OLE.

Farmers were educated about the dangers of crop spraying and muck spreading.

Anglers were made aware of risks of carrying rods and casting lines near OLE.

Drone pilots taught about the dangers of flying near the railway.

5.5.64 Battery charging also increases the potential for staff and trespassers to come into contact with live equipment. Mitigation measures include the product approvals process and introduction of new operating processes.

5.5.65 Due to the combustion characteristics of hydrogen there will be a need for safety protection equipment and processes to safeguard against risks of ignition. As well as this, consideration of the Control of Major Accident Hazards (COMAH) regulations will be required as this will limit the volume of fuel which can be stored and thus the volume of fuelling which can be undertaken¹²¹. As with battery power, this could be addressed by suitable mitigations in the product approvals process and any newly introduced operating procedures and railway standards.

5.5.66 Industry experience has been developed around the safe operation of hydrogen through the deployment of hydrogen rail traction in Germany as outlined in Case Study 1 and within non-rail sectors where hydrogen is safely transported and used.

ENVIRONMENTAL – STRATEGIC BENEFITS

5.5.67 There are two main strategic benefits associated with the environmental theme:

- air quality benefits; and
- noise benefits.

These are explored in greater detail below.

AIR QUALITY BENEFITS

5.5.68 The proposals made as part of this traction decarbonisation network strategy could ultimately provide a long-term solution to air quality issues which have been explored as part of the rail industry Air Quality Strategic Framework¹²². However, these issues will need to be resolved significantly in advance of the decarbonisation initiatives being recommended as part of this work.

5.5.69 Clarity around the decarbonisation solution to be deployed and the timescales in which it is deployed will be essential in order to ensure any short-term mitigations required to solve the air quality problem are efficiently deployed with the most appropriate solutions introduced in the right locations at the right times. This will bring both strategic opportunities and risks as the relationships between short-term air quality and longer-term decarbonisation solutions are understood.

¹²¹ RSSB, 2020, Intelligent Power Solutions to Decarbonise Rail – Hydrogen Energy: Feasibility and Concept Design of Future Hydrail Enabled Railway Depots, p. 75.

¹²² RSSB, 2020, Air Quality Strategic Framework.

5.5.70 Line of route air quality and noise benefits are not currently covered within the TDNS economic analysis as these benefits have not been isolated or analysed at this stage but will require further consideration.

5.5.71 In the absence of a programme of decarbonisation it is difficult to understand the extent of these opportunities and risks. The relationship between these two major programmes will be considered in greater detail through the development of a programme of decarbonisation as part of the TDNS Programme Business Case.

NOISE BENEFITS

5.5.72 In general terms, the decarbonisation of the network will deliver a net reduction in the noise impact of the operation of the railway. Noise from the operation of trains has three principal components:

- aerodynamic noise;
- rolling rail contact noise; and
- engine noise.

5.5.73 Alternative traction trains are generally quieter in engine operation than diesel stock although all rolling stock including diesel is quieter than the recommended legal limit in residential areas. This reduction in noise will also translate into an improved on-board environment for passengers on multiple unit-operated services as underfloor diesel engines are not required.

5.5.74 Alternative traction will enable a higher proportion of trains that use electric motors to operate, which removes the engine noise component for passengers. For electric trains at very high speeds this would be accompanied by a small increase in aerodynamic noise from pantographs.

WIDER ECONOMY – STRATEGIC BENEFITS

5.5.75 There are two main strategic benefits associated with the wider economy theme:

- job creation and “Levelling Up”; and
- new technology development learning.

These are explored in greater detail below.

JOB CREATION AND “LEVELLING UP”

5.5.76 The volume of work to be delivered to achieve traction decarbonisation will be significant.

5.5.77 Opportunities will emerge for a new generation of overhead line engineers, technicians and lines-people as well as rolling stock engineers for both electric and alternative traction types. As well as this there will be opportunities within design and development activities and management as well as operations and staff required for ongoing maintenance.

5.5.78 There is already a forecast skills gap for the rail industry over the coming five years¹²³. Opportunities to continue to attract young talent to rail is key and the establishment of these green sector roles providing decarbonisation for the rail sector can be leveraged.

5.5.79 A consistent programme of work spanning the next thirty years and beyond will be required to successfully decarbonise traction. This will mean there could be both stability and longevity for those seeking these roles, with these also being roles within the green economy.

5.5.80 Due to the significant amount of unelectrified railway in Scotland, the North, Midlands, Wales and South West there is a strong likelihood that many new roles will be established in these areas, contributing to the “levelling up” of the economy.

NEW TECHNOLOGY DEPLOYMENT LEARNING

5.5.81 As outlined earlier there is currently only a small proportion of hydrogen energy used in the UK economy. Hydrogen has been identified as the ideal solution to decarbonise a number of sectors of the economy, including industry, shipping and home heating as well as with other transport modes as outlined earlier in this section.

5.5.82 Hydrogen application in rail is relatively advanced compared with other sectors and there is a strong possibility that rail could become both an early adopter and long-

¹²³ The National Skills Academy Rail, 2019, NSAR – An overview – National Skills Academy for Rail, p. 2.

term consumer of hydrogen. There is commercial interest from industrial gas supply companies and others in supplying hydrogen for rail application due to the size and stability of the requirements over a significant period of time¹²⁴.

5.5.83 The early adoption of hydrogen and skills and knowledge acquired by key individuals and groups with rail could be used to support the wider sectors of the economy as the use of hydrogen expands into these sectors. Equally work done through rail could encourage the development of highly cost-effective and competitive fuel supply solutions which can then be deployed more widely across the economy. The ability for this and the sharing of learning, experience and knowledge could ultimately support the adoption of hydrogen across other sectors more rapidly, bringing wider decarbonisation and economic benefits.

¹²⁴ RSSB, 2020, Intelligent Power Solutions to Decarbonise Rail – Hydrogen Energy: Feasibility and Concept Design of Future Hyrail Enabled Railway Depots, p. 3.

STRATEGIC BENEFITS SUMMARY

5.5.84 This section has outlined the key strategic benefits for each of the six themes identified as part of the strategic case for rail traction decarbonisation. The aspects explored are summarised in Figure 11 below.

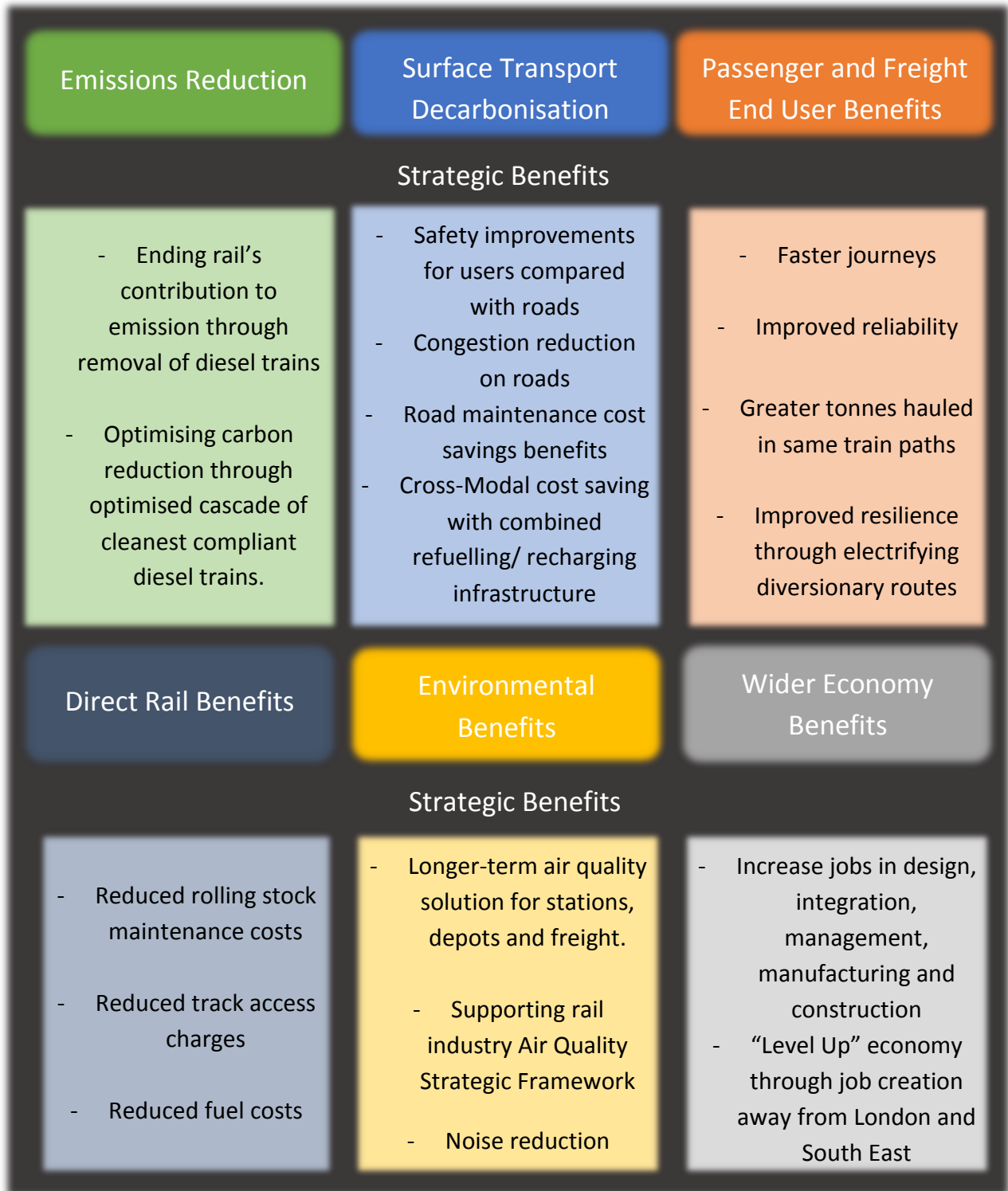

Figure 11: Summary of the Strategic Benefits of traction decarbonisation

STRATEGIC AND ECONOMIC BENEFITS SUMMARY

5.5.85 This section has outlined a significant number of benefits of traction decarbonisation and outlined the argument for using modal shift to rail as a contributor to the decarbonisation of the wider surface transport sector. The latter will play a key part of the DfT's Transport Decarbonisation Plan.

5.5.86 Appendix 5 provides a summary of the benefits outlined and the extent to which they are considered within TDNS from a qualitative and quantitative perspective.

5.6 DECARBONISATION TRACTION OPTIONS

5.6.1 As outlined in section 5.2, previous work has shown there are likely to be three traction technologies (battery, electrification and hydrogen) which will be sufficiently mature to achieve net-zero emissions in rail. These three technologies form the basis of the analysis provided with the Traction Decarbonisation Network Strategy work.

5.6.2 This section provides an overview of the three traction technologies, but also outlines a range of options which could be deployed to achieve both interim and end state decarbonisation of traction. These can be broadly arranged into two categories: Transitional Solutions and Full Solutions.

5.6.3 Transitional Solutions will support meeting interim targets required for the UK to achieve net zero greenhouse gas emissions. Full Solutions will be required to achieve zero emissions by 2050.

5.6.4 Where discrete projects are being developed from the recommendations made as part of TDNS consideration should be given to all the options outlined in this section during the optioneering process.

TRANSITIONAL SOLUTIONS

5.6.5 This section outlines the Transitional Solutions to achieve reductions in emissions from the rail network. Aspects considered within this section are not actively considered within TDNS but are presented here to ensure that those undertaking full and detailed appraisals are aware of potential options beyond deploying battery, electric and hydrogen rolling stock.

5.6.6 This section addresses five different possible options, describing them and outlining the circumstances under which they could be considered to support traction decarbonisation. The five areas are:

- utilisation of the existing electrified network;
- improved-efficiency diesel engines;

- emissions efficiency through Digital Railway;
- changes in freight operations; and
- is heavy rail the best option?

UTILISATION OF THE EXISTING ELECTRIFIED NETWORK

- 5.6.7 Around 30% of all current emissions from diesel trains come from trains operating over electrified sections of the network. Many of these trains require diesel power to operate on parts of their journeys and as a result are operated as diesel-only units. This is especially true for freight services which often operate for part of their journey away from the electrified network.
- 5.6.8 As well as this, there are areas of the existing electrified network where there are known power supply problems. In the most extreme cases, train numbers are being limited, meaning that some bi-mode services are running as diesel rather than electric to limit current draw.
- 5.6.9 If all trains operating with diesel traction over electrified infrastructure were to operate using the electrified infrastructure this is highly likely to require a significant number of power supply upgrade projects on those parts of the network where an autotransformer system is not installed.
- 5.6.10 Recent work undertaken exploring the potential enhancements works required within the York to Newcastle corridor has suggested that in this area alone an uplift of up to 167% in power may be required if all trains planned to operate from beyond 2030 were to utilise the electrified infrastructure¹²⁵.
- 5.6.11 A desktop exercise undertaken by Network Rail's Design Delivery (NRDD) organisation as part of TDNS has identified a number of areas of the existing electrified network where power supply uplift would be required if the existing infrastructure was to be utilised by all trains currently operating.
- 5.6.12 As well as identifying five supply points which are already at or over maximum capacity today if all trains including freight services were to utilise the existing infrastructure, there would be thirty-eight supply points which would require enhancement. This covers around 41% of all supply points on the network. Indications of capacity exceedance range from as little as 2% up to a maximum of 313%.
- 5.6.13 As the existing electrified network is outside of the direct scope of the TDNS, costs associated with increasing the supply capability of the existing electrified

¹²⁵ Network Rail, 2020, CMSP – Church Fenton to Newcastle Strategic Question, p. 23.

infrastructure are not currently included in this analysis. Further work will take place for the full TDNS PBC building on the desktop exercise undertaken by NRDD.

DIESEL – IMPROVED EFFICIENCY

5.6.14 There are two main sub-types of diesel traction: diesel-mechanical and diesel-electrical. The technical characteristics of these trains are outlined in Appendix 6.

5.6.15 As well as replacement of diesel engines to those with improved efficiency a number of other opportunities exist to improve the emissions efficiency of existing diesel trains. These include the following areas, which are explored in greater detail below:

- use of biofuels;
- conversion to using natural gas; and
- traction combinations with diesel.

BIOFUELS

5.6.16 Biofuels are a potential solution to diesel fuel with minimal or no changes required to the combustion process as outlined above.

5.6.17 Biofuels can be deployed either in full or as part of a biofuel/diesel blended mixture in order to improve the emissions characteristics of diesel. There are three main generations of biofuel¹²⁶.

- 1st Generation Biofuels – these are well established crop fuels which require significant resources and land which could be otherwise be used for human crop food consumption.
- 2nd Generation Biofuels – these are often referred to as advanced biofuels and are produced from a number of other types of biomass. Whilst this requires sophisticated chemical and manufacture processes which drives increases in costs, they are less resource consumptive.
- 3rd Generation Biofuels – these use algae to generate fuel, typically from waste material. These are potentially more efficient but are still in their infancy.

5.6.18 For rail traction decarbonisation specifically, it is unlikely that there will be any availability of biofuels at scale as this is more likely to be used in areas which will struggle to decarbonise by 2050 such as aviation and shipping¹²⁷. It is assumed that access to biofuels is not a credible solution to decarbonise rail traction. There are also potential air quality issues with biofuels.

¹²⁶ RSSB, 2018, T1145 Options for Traction Energy Decarbonisation in Rail, p. 15.

¹²⁷ IPCC, 2012, Renewable Energy Sources and Climate Change Mitigation, Chapter 2: Bioenergy, p. 252.

NATURAL GAS

5.6.19 Natural Gas, whilst still a GHG emitter itself, can be a viable alternative to diesel and has the potential to reduce emissions rates compared with diesel. It can be stored in two main ways: highly compressed (CNG) or liquid stored at low temperatures (LNG). The global supply is plentiful and as such it is relatively cheap in some geographical areas¹²⁸. Whilst the fuel is being encouraged for use in certain areas of the world such as North America and Eastern Europe, prices would have to be significantly reduced in the UK to make it commercially viable for traction purposes¹²⁹.

5.6.20 There are a number of safety considerations which would be required to be made for application in a rail environment¹³⁰. With a significantly lower energy density compared with diesel, much larger volumes are required to achieve a comparable operational range. For freight services especially this would mean the addition of fuel tender vehicles which could increase operational complexity and potentially impact commercial viability of services.

TRACTION COMBINATIONS (WITH DIESEL)

5.6.21 There are two potential methodologies of combining diesel fuel use with a secondary technology, hybridisation and multi-mode operation. These are explored in greater detail below.

5.6.22 Whilst hybrids and multi-mode operations are not the most operationally efficient due to the fact that trains are carrying multiple traction methods thus increasing weight, train complexity and maintenance requirements, these traction types do have the benefit of being able to use available infrastructure rather than relying on diesel combustion (i.e. a diesel train can use the electrical contact system when available). The ability to reduce the amount of diesel combustion would aid decreasing overall CO₂e emissions.

5.6.23 Implementing the volume of electrification required to achieve traction decarbonisation will take time. Having bi-mode vehicles operating in key strategic locations will allow incremental benefits to be realised as more and more of the network becomes electrified. This will be essential to assist in meeting interim emission targets. Where these trains can be converted with relative ease at a future point in time to a lower or zero carbon alternative this is even better as the full economic life of the vehicle can be realised.

¹²⁸ RSSB, 2018, T1145 Options for Traction Energy Decarbonisation in Rail, p. 15-16.

¹²⁹ RSSB, 2018, T1145 Options for Traction Energy Decarbonisation in Rail, p. 16.

¹³⁰ RSSB, 2018, T1145 Options for Traction Energy Decarbonisation in Rail, p. 16.

5.6.24 Recent work undertaken by Loughborough University on behalf of RSSB has indicated the potential to realise emissions reduction in high-speed diesel-electric bi-mode trains of up to 8% if selective engine shutdown technology is used, with some engines switched off when they are not needed¹³¹.

HYBRID DIESEL TRAINS

5.6.25 Hybridisation is where multiple traction modes are used simultaneously to improve fuel consumption. For diesel rolling stock this usually takes the form of a diesel engine and battery system working together with the aim of reducing diesel usage in high energy requirement areas (i.e. accelerating or moving from a stationary position).

5.6.26 Both diesel-mechanical and diesel-electric trains can be fitted with energy recovery and storage equipment to form a hybrid architecture. Hybrid architectures allow energy to flow automatically into and out of the energy storage system to make the most efficient use of the primary energy source, in this case a diesel engine.

5.6.27 The technical functionality of diesel hybrid vehicles is provided in Appendix 6.

MULTI-MODE TRAINS WITH DIESEL

5.6.28 Multi-Modes are where two (or three) traction systems are used to operate the vehicle. Rather than these systems working together as with hybrids they operate independently of each other with switch over between modes required. This is typically done when stationary in stations but more recently automatic power change over (APCO) has been introduced in certain areas. This uses a track side balise to instruct the train to change between traction types automatically. Most trains currently on the network which fall into this category are diesel/electric bi-modes.

EMISSIONS EFFICIENCY THROUGH DIGITAL RAILWAY

5.6.29 Driving styles can have an impact on fuel efficiency for both electric and diesel rolling stock. Depending on intensity of driving, especially during acceleration stages, this can increase electrical power draw or fuel consumption and hence the CO_{2e} emitted per train.

5.6.30 The advent of Driver Advisory Systems (DAS) and Connected-DAS could be a method by which driving style is normalised through these systems advising drivers how they can drive more carbon efficiently. Analysis undertaken by RSSB suggest that adjusting driving speed based on predicted arrival times at stations could yield up to a

¹³¹ RSSB, 2020, Decarbonising High-Speed Bi-Mode Railway Vehicles through Optimal Power Control, p. 17.

10% reduction in CO₂ emissions of high-speed trains compared with maximum acceleration and deceleration rates¹³².

5.6.31 Whilst these systems are not yet widespread, the roll out of the Digital Railway programme is likely to increase the number of vehicles fitted with these systems. Equally any new rolling stock fitted with these systems could be used to improve fuel efficiency and reduce emissions. Whilst the overall effect of these systems is likely to have a marginal impact overall, they could be used effectively to support wider interim emissions targets outlined in Table 3.

CHANGES IN FREIGHT OPERATIONS

5.6.32 A large number of freight services operate with diesel traction despite significant running over electrified infrastructure. This is usually because the “last mile” or final sections of the journey do not have electrified infrastructure. Recent introduction of Class 88 diesel/electric bi-mode locomotives is beginning to demonstrate the opportunities of utilising existing electrified infrastructure.

5.6.33 The extent of electrification on the network will have to increase if traction decarbonisation is to be achieved. It may, however, be appropriate to amend existing freight operating practices to support reduction of overall emissions. For example, rather than a freight train taking a full diagram of wagons from terminal to terminal it may be more appropriate to haul these diagrams to an arrival road or section of the network within the “last mile” of the terminal with a smaller shunting locomotive then used to carry the load into the terminal.

5.6.34 A number of examples of battery powered shunting locomotives are in existence now. These are principally operated for low speed high tonne freight movements (see case study 3 overleaf).

¹³² RSSB, 2020, Decarbonising High-Speed Bi-Mode Railway Vehicles through Optimal Power Control, p. 17.

Case Study 3 -Clayton Battery Locomotive Shunter

Clayton Equipment have recently introduced a new range of 80-135 tonne hybrid Bo-Bo, Bo-Bo-Bo and Co-Co shunting locomotives.

These locomotives can be manufactured, tested and commissioned in relatively short time frames and provide high torque and haulage capability with over **397kN tractive effort**, delivering **2500-tonne loads**, multiple working and operating on a **maximum gradient of 4%**.



Using lead-acid battery technology with on board hybrid batter charging these shunting locomotives can offer long-range haulage at relatively low speeds with zero-emissions. As well as this they operate at low noise levels and provide opportunities for operational and maintenance cost savings.

Units are currently in operation with groups in the UK including TATA Steel, Sellafield, Beacon Rail, London Underground, SPT and Ford.

Information and Picture provided with permission from Clayton Equipment

5.6.35 Whilst these vehicles have very limited top speeds which would be insufficient for main line operations, it may be possible to reduce the overall volume of electrification required and make the operation of the railway more emission-efficient.

5.6.36 A real-world example of where this style of operation occurs on today's network can be found at the Felixstowe Freight Terminal. Rather than a freight service from here travelling towards London on the Great Eastern Main Line (GEML) operating on diesel traction (due to the branch between Felixstowe and Ipswich being unelectrified), a diesel locomotive hauls the load from Felixstowe to Ipswich where it is swapped for an electric locomotive. There are a number of other examples of this around the network.

IS RAIL THE BEST OPTION?

5.6.37 There are areas of the network where it is possible that the provision of a heavy rail connection may not be the most appropriate solution for optimum passenger use. Equally decarbonising these parts of the network may require significant capital

investment in infrastructure and rolling stock which may not be the most optimum and cost-efficient investment to decarbonise.

5.6.38 These areas of the network would have to be completely devoid of freight traffic or potential freight traffic and as a result there are very few areas where this could be implemented.

5.6.39 In appropriate locations it may be possible to replace a heavy rail connection with either a light, or very light rail connection or an improved bus service (using zero-carbon buses). As well as being a more cost-efficient way to achieve decarbonisation these proposals could improve services and connections for local communities, assuming these services were integrated with other transport modes, including heavy rail services.

5.6.40 Case study 4 overleaf shows how the deployment of a Very Light Rail (VLR) technology could support decarbonisation, provide improved services and be achieved at a reduced capital cost.

Case Study 4 - Very Light Rail

Very Light Rail (VLR) is an emerging concept to describe vehicles which use rails, but typically weigh less than one tonne per linear metre. Due to their reduced weight the associated track and infrastructure they operate on can be less substantial.



VLR has emerged by transferring proven low-cost automotive technology into the rail environment. This can yield a number of benefits, which include:

- providing eco-friendly vehicles without the need for significant heavy rail infrastructure enhancements (i.e. overhead line electrification);
- using simpler lightweight infrastructure materials, reducing costs of new infrastructure;
- using simpler very lightweight vehicles reducing costs, or allowing larger numbers of vehicles to be provided;
- potential to deploy automation, removing key areas of operational cost; and
- reduction in the amount of buried service relocation required due to factory manufacturing of track system. This is often a cost area which causes issues in the deployment of traditional tram and light rail systems.

The technology is being targeted at segregated branch lines and re-openings as it can only be deployed away from mixed traffic areas. Some of its key specifications are summarised below:

- 18.5m long vehicle with extensive use of composite materials for body structure
- Persons of Reduced Mobility-Technical Standards for Interoperability compliant interior with 56 seats, one wheelchair space and room for up to sixty standing

A demonstration vehicle is currently being built and traction testing is completed. Further performance testing is planned during 2020 with demonstrations to take place in 2021.

FULL SOLUTIONS

5.6.41 The strategic case has outlined the three potential solutions being appraised as part of this document: battery, electric and hydrogen traction. This section outlines the technical aspects of the options. Further information is provided in Appendix 6.

5.6.42 Whilst the opportunity to use traction mixes is described, these are not considered as part of the TDNS appraisal. Often decisions around the deployment of traction mixes are driven by local geography or operating principles. These aspects will need to be considered by the Network Rail Regional teams when discrete project business cases are developed.

ELECTRIC TRACTION

5.6.43 Electric rolling stock takes the form of locomotives and multiple units, which share the common characteristic of taking electrical power from a continuous contact system and converting and controlling it to produce tractive effort. Locomotives will have all wheels driven, whereas the amount and distribution of motored wheels on multiple carriage units varies.

5.6.44 The UK network makes use of three different power systems, each with their own contact system:

- 750 V DC via top contact conductor rail, also known as third rail;
- 25 kV AC via Overhead Line Equipment (OLE), also known as Overhead Contact System (OCS); and
- DC overhead line systems used by Tyne and Wear Metro and Sheffield Supertram when operating over Network Rail infrastructure.

5.6.45 Electric trains powered by a contact system have the following advantages:

- energy is not limited by a requirement to carry a finite amount of fuel;
- as no energy storage equipment needs to be carried, mass compared with other trains types is lower;
- electric systems can be subject to short term overload to improve acceleration performance as the performance ceiling is usually limited predominantly by excess heat alone (especially when compared with onboard internal combustion engines); and
- under braking, energy can be regenerated and returned to the distribution network for use elsewhere, such as other trains.

5.6.46 In summary, if supplied with adequate infrastructure, electric trains can accelerate harder and travel faster than trains which carry energy onboard.

5.6.47 Electric trains powered by a contact system have the following disadvantages:

- contact systems and power distribution networks are required the full length of the route where the train is expected to fully function;
- the electrification system must have the capacity to support all the trains using it, or the performance of the train must be moderated; and
- the power distribution systems are reliant on the national grid to be effective, with failure potentially leading to a major operational event.

5.6.48 In summary, traditional electric trains require dedicated infrastructure, in the form of a contact system and power distribution network, along the full length of the route intended for their travel.

BATTERY POWERED TRACTION

5.6.49 Battery-powered trains are electric multiple units and locomotives which carry batteries in order to provide traction power for in-service use.

5.6.50 All trains carry some form of battery. This is to start the on-board systems or connect to the infrastructure to start primary energy sources e.g. engines or raise the pantograph. They also supply lighting and ventilation for a limited time during primary power failure. Some modern multiple units are sometimes able to make low speed moves around depots on such batteries.

5.6.51 The performance characteristics of battery powered trains are limited in some areas, such as range and top speed. Although it is possible to continue to fit more and more batteries to increase performance, the economic benefit may diminish. The market conditions in 2019 suggest the following performance characteristics:

- a range of 60-80 km on battery power. This depends on battery size, weight, average speed, terrain, stops and auxiliary requirements, operational reserve requirements and demanded battery warranty;
- realistic top speed of approximately 75 – 100 mph;
- fifteen minutes to fully charge;
- increased mass compared with an electric train; and
- auxiliary power e.g. heating and air conditioning, may need to be managed when on battery power to meet range requirements.

5.6.52 Charging on the move can make use of existing electrification systems i.e. 25 kV OLE and 750 V third rail, assuming the infrastructure has the capacity. Stationary charging can also use these methods, but other, potentially cheaper and/or faster systems may also be employed using systems specifically designed for the task.

5.6.53 Battery trains have the following advantages:

- they can travel on parts of the network without a contact system;
- they can recharge on the move from the existing contact system which under some circumstances can negate the need for additional infrastructure;
- require only electricity to recharge;
- quiet and produce no pollutants at the point of use;
- batteries can be near seamlessly integrated into existing electric trains; and
- they can bring additional benefit to a contact system in the form of peak load reduction and advanced rescue capability under power outage.

5.6.54 Battery trains have the following disadvantages:

- the cost and weight of batteries leads to an energy storage limit when it comes to economics and practicability;
- the energy storage limit leads to a range limit, and this range is traded for average speed and auxiliary load; and
- top speed is practically limited when compared with electric traction.

5.6.55 In summary, battery trains allow the introduction of emission-free trains on routes where the performance requirements do not exceed those of the trains. There is a potential requirement for electric charging infrastructure to facilitate this.

HYDROGEN POWERED TRACTION

5.6.56 Hydrogen-powered trains are electric multiple units which carry hydrogen, fuel cells, and batteries in order to provide traction power. There are other devices for the conversion of hydrogen to mechanical energy, such as internal combustion engines, and turbine solutions, but fuel cells are currently the most common.

5.6.57 The market in 2019 suggests hydrogen-powered trains will have the following capability:

- a predicted range of around 1000 km. This depends on tank size, weight, average speed, terrain, stops and auxiliary requirements and operational reserve requirements;
- economic top speed of approximately 90 - 100 mph; and
- fifteen minutes refuelling time.

5.6.58 Hydrogen-powered trains need to be regularly refuelled with compressed hydrogen gas. Whilst operation-specific, it is expected trains would need to be refuelled roughly once every twenty-four hours, such as during overnight stabling.

5.6.59 Hydrogen-powered trains have the following advantages:

- they can travel on parts of the network without a contact system;
- there are quiet and produce no pollutants at point of use; and
- can be configured as a bi-mode to be powered by a contact system.

5.6.60 Hydrogen-powered trains have the following disadvantages:

- for a specified range, hydrogen storage consumes around eight times the volume of diesel using 350 bar storage equipment. Long range application may lead to reduced saloon space;
- to date no hydrogen-powered trains for freight or capable of 125 mph have been announced; 145 km/h (90 mph) is the current maximum being made available;
- fleet deployment currently also requires a source of suitable hydrogen to be identified or constructed; and
- the efficiency of electrolysis, compression and the fuel cell combined lead to energy consumption around three times that of conventional electric trains.

5.6.61 In summary, hydrogen trains are capable delivering relatively long-distance services at speeds competitive with mid power diesel multiple units with no emissions at point of use. The carbon intensity is dictated by the footprint of the method used to produce the hydrogen. Hydrogen trains require little change to the mainline infrastructure; however, they require new fuelling systems (and potentially hydrogen production systems) to be constructed.

TRACTION COMBINATIONS WITHOUT DIESEL

5.6.62 The ability to combine different traction technologies in a similar vein to diesel electric combinations is also possible. Currently there is only the option to provide an electric-battery bi-mode train; however, electric-hydrogen trains have been identified as a possibility.

5.6.63 Whilst the mixture of multiple traction technologies is not optimal from a weight or maintenance perspective, the flexibility that bi-mode trains offer will be beneficial for services operating beyond the extent of the future electrified network.

5.6.64 Bi-mode operations will not only allow realisation of incremental benefits enabled by electrification as this is expanded progressively on the network, but also allow an interim zero-carbon traction solution to be deployed for areas of the network where electrification may take place post-2050. The extent of this will not be clear until the TDNS PBC is provided in October 2020.

- 5.6.65 Unlike with diesel, a bi-mode solution using the alternative energy solutions in conjunction with electric traction will provide a zero-emissions solution.
- 5.6.66 The extent to which electrification will be required to decarbonise traction for freight and long-distance passenger services as outlined in section 5.8 will mean that delivery of infrastructure has the potential to continue beyond the 2050 deadline in order to maximise delivery efficiency. This begins to be outlined as part of the Management Case but will ultimately be addressed as part of the TDNS PBC to be provided in October 2020.
- 5.6.67 For areas of the network where an end state solution is not achievable by the 2050 deadline, using alternative energy solutions to provide a zero-emission solution on an interim basis would become essential. Bi-mode operations using the technologies outlined in this section would provide the much-needed support to make this a reality.
- 5.6.68 One opportunity that can be considered when deploying bi-mode rolling stock is the possibility of providing discrete or discontinuous electrification. Discrete electrification is where a small section of railway is not electrified due to local constraints such as a bridge or tunnel. Discontinuous electrification is where sections of electrification are provided alongside sections of unelectrified railway, creating islands where electric traction can be used.
- 5.6.69 Work undertaken by Loughborough University on behalf of the RSSB has indicated that the deployment of discontinuous electrification can bring significant carbon benefits with less infrastructure required¹³³.
- 5.6.70 It should be noted that deployment of discontinuous and discrete electrification is not suitable for freight traffic as electric freight services require continuous contact with the electrical contact system. Also, infrastructure costs associated with these types of electrification may be higher as more feeding stations may be required.
- 5.6.71 The choice of deploying discontinuous or discrete electrification is for very geographically specific reasons and requires careful consideration during project development and optioneering. As TDNS is using a top-down appraisal it does not consider either discontinuous or discrete electrification. These will be considered by regional teams during project development.
- 5.6.72 The traction technologies which have been considered as part of TDNS have been included due to known characteristics of vehicles and their commercial availability, whether in revenue service or having undergone significant trials. Such examples

¹³³ RSSB, 2020, Decarbonising High-Speed Bi-Mode Railway Vehicles through Optimal Power Control (COF-IPS02), p. 14.

include the Alstom Coradia iLINT (outlined in Case Study 1) and Siemens Desiro ML ÖBB Cityjet eco. Battery and hydrogen traction technologies are represented in the UK by ongoing first-in-class units and well-developed proposals from ROSCOs and train manufacturers.

5.6.73 Other alternative traction technologies are beginning to emerge such as ammonia and liquid air traction. These are in their infancy and currently do not meet the level of development or deployment outlined by the examples above. As a result they are not considered by TDNS at this stage. Technologies which mature in time and have characteristics comparable with battery or hydrogen will be considered in future TDNS refreshes if they are sufficiently advanced.

EMBODIED CARBON AND ETHICS

5.6.74 Embodied carbon is the CO₂e emitted in the production of materials used. It includes the energy used to extract and transport raw materials as well as emission from the manufacturing process¹³⁴. There are also a number of ethical considerations.

5.6.75 Whilst the analysis within this document does not explicitly explore the embodied carbon or ethical nature of each of the technologies and ascribe values to them Appendix 7 outlines some of the key considerations for battery, electrification and hydrogen.

5.7 METHODOLOGY

5.7.1 This section outlines the methodology used to develop the Traction Decarbonisation Network Strategy.

5.7.2 The section introduces the technical considerations which have been established through previous research work underpinning the conclusions made by the Rail Industry Decarbonisation Taskforce and outlines how these technical considerations have been used to identify areas of the network where there is a “single technology solution” and those where “multiple technology solutions” could be deployed.

5.7.3 The methodology used for the economic appraisal is outlined within section 6.4.

5.7.4 The section concludes by outlining the programme of decarbonisation priorities which have been considered at this stage to define the programme of delivery which feeds into the economic analysis. This programme is only indicative at this stage. The Programme Business Case to be issued later this year will provide a more comprehensive programme of decarbonisation as part of the management case following consultation with key members of the rail industry.

¹³⁴ University College London, 2018, Embodied Carbon Factsheet, p. 2.

TECHNICAL CONSIDERATIONS

5.7.5 As outlined in section 5.6 each of the three technologies has technical limitations meaning that they are not suitable for application in every circumstance with each technology having advantages and disadvantages. Detailed technical ability is extensively covered in RSSB research work T1145, T1160 and the Rail Industry Decarbonisation Taskforce publications but ultimately Figure 12, below, summarises the key technical abilities of the technologies.

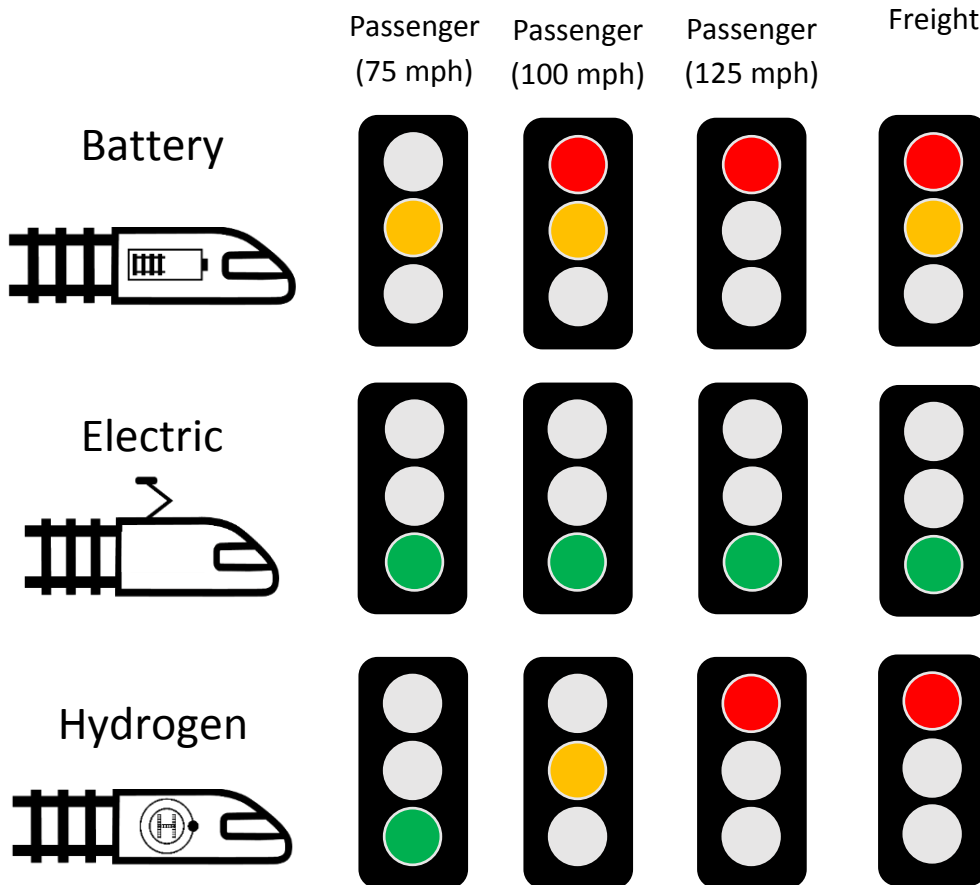

Figure 12: Summary of the technical abilities of the three traction technologies considered as part of TDNS

5.7.6 An economic model has been developed to undertake the economic appraisal as part of this document evaluating costs, benefits and direct emissions. In order to support inputs into this appraisal a decision tree has been developed to identify any segments of the unelectrified network where specific technologies may not be feasible due to their technical or operational characteristics, outlined in Figure 12 above, whilst still providing a level of service at least equal to the current service. This has identified segments of the unelectrified network where a “single option solution” exists.

- 5.7.7 Where there is no clear solution from a technical perspective this leaves the possible application of “multiple solutions”. These multiple solution segments will then be appraised using the economic model and operational considerations.
- 5.7.8 The RSSB research work summarised in Figure 12 above identifies that electric traction power is the only currently available low-carbon non-diesel solution able to provide services over speeds above 100 mph. It is also the only practical freight traction power solution, so routes with significant freight movements have been assigned to electric traction as the “single option solution”.
- 5.7.9 A high-level review of the intensity of use of the network indicates a number of areas of the network where there are clear choices for both battery and hydrogen technologies based on the technical capabilities and limitations of these technologies. For these areas of the network battery and hydrogen traction have been assigned as the “single option solution”.
- 5.7.10 For the remaining areas of the network where there is no clear option, a combination of economic analysis and operational considerations have been used to identify a proposed solution.
- 5.7.11 The decision tree below in Figure 13 summarises this approach.

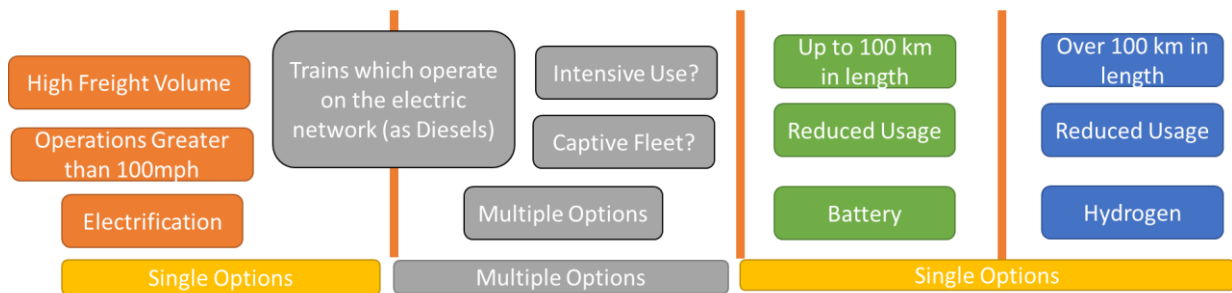

Figure 13: Decision Tree showing criteria for “single” and “multiple” option allocation

- 5.7.12 A pragmatic approach has been taken towards freight operations as the network wide assessment indicates that around 98% of the network would require electrification if all freight was to be operated entirely with electric traction. This is not unexpected given the go-anywhere nature of freight.
- 5.7.13 For a number of routes where freight volume did not meet the definition of “high volume” these segments were identified as “multiple option”. A number of these segments were subsequently recommended for electrification given the freight operations which occur. A smaller number were not proposed for electrification given the limited freight operations or volatility of freight flows identified. This approach would result in residual emissions of around 50 million kgCO₂e per year (around 3% of all traction emissions today) unless an alternatively fuelled freight locomotive was deployed.

PROGRAMME PRIORITIES

5.7.14 This document makes some high-level assumptions on the delivery programme required to achieve the outputs proposed in the next sections. This programme will be consulted with stakeholders and the analysis updated as a result of any changes before the completion of the TDNS Programme Business Case in October 2020.

5.7.15 It is envisaged that the key considerations made for prioritisation of the programme will include:

- carbon reduction contribution;
- air quality potential benefit (long-term solution);
- contribution to decarbonisation of a wider journey;
- achieves homogeneity of a fleet or service group;
- passenger aspiration priority;
- freight aspiration priority;
- impact on users; and
- operational considerations.

5.7.16 These items will be explored in greater detail in the TDNS Programme Business Case document to be completed in October 2020. The extent of the current programme used for economic modelling purposes and the key considerations from this are outlined in greater detail in the management case.

5.8 TRACTION DECARBONISATION RECOMMENDATIONS

5.8.1 The recommendations contained within this section ultimately outline what would be required in order to achieve net-zero emissions from rail traction based on known technological capability. The extent to which rail will be required to decarbonise traction in order to meet decarbonisation of the wider economy will be outlined as part of the DfT's Transport Decarbonisation Plan.

5.8.2 The map in Figure 14 overleaf shows the outputs of the methodology on the national network. A detailed geographic breakdown of these recommendations alongside commentary associated with the recommendations are outlined in Appendix 8.

5.8.3 The recommendations do not indicate a delivery prioritisation and simply represent the end-state position for traction decarbonisation. The recommendations are far reaching and will require a significant period of time to deliver and their delivery may extend beyond 2050 in order to maximise efficiency and minimise disruption to the network. As such, in order to achieve zero emissions by 2050 there may be a need to deploy interim solutions for certain areas. This notion begins to be explored in the

commentary provided alongside the recommendations but will need further consideration as the programme of decarbonisation emerges as part of the PBC.

- 5.8.4 The final recommendations made as part of the TDNS Programme Business Case will illustrate a programme of decarbonisation. The implications of these recommendations on the Network Rail regions are explored in sections 5.9 - 5.13 of this document.
- 5.8.5 In deploying the methodology outlined in section 5.7 there were a number of areas of the network which were only marginally within the parameters of “single option”.
- 5.8.6 For electrification, these areas are identified on the maps as “ancillary” electrification. For the purpose of the analysis these routes have not been split out as the methodology identifies them as requiring electrification. However, it was felt prudent to identify areas which when assessed emerged marginal. For battery and hydrogen, where distance is on the fringe of the capability of the relevant technology this has been identified in the supporting commentary contained within Appendix 8.
- 5.8.7 At a national scale, of the 15,400 STKs of unelectrified railway, the following volumes of battery, electrification and hydrogen are proposed for deployment:
- c. 11,700 STKs of electrification is required for long-distance high-speed passenger and freight services;
 - hydrogen train deployment over c. 900 STKs of infrastructure;
 - battery train deployment over c. 400 STKs of infrastructure; and
 - there are 2,400 STKs where a single technology is not immediately clear.
- 5.8.8 Of this 2,400 STKs, further analysis suggests the deployment of:
- a further c. 1,340 STKs of electrification;
 - hydrogen train deployment over c. 400 STKs of infrastructure;
 - battery train deployment over c. 400 STKs of infrastructure; and
 - there remains 260 STKs where a technology choice is yet to be made.
- 5.8.9 These recommendations would result in up to 96% of passenger unit kilometres operated using electric traction with the remaining 4% operated using hydrogen and battery units. For freight, around 90% of train kilometres could be operated electrically with the remaining 10% requiring either diesel or alternative traction locomotives.
- 5.8.10 Whilst these recommendations are extensive, there are a number of areas where freight services would operate beyond the proposed electrification. Modelling suggests this residual emission to be around 50 million kgCO₂e per year (this is around 3% of today’s total traction emissions). The residual emissions from these remaining services would either need to be offset or removed using an alternatively

fuelled freight locomotive (which is not currently available in the UK) in order to remove the requirement to electrify almost all of the network.

5.8.11 The need to provide electrification to support long-distance high-speed CrossCountry services has also been clear and has resulted in both complementary and further electrification beyond that identified for freight services.

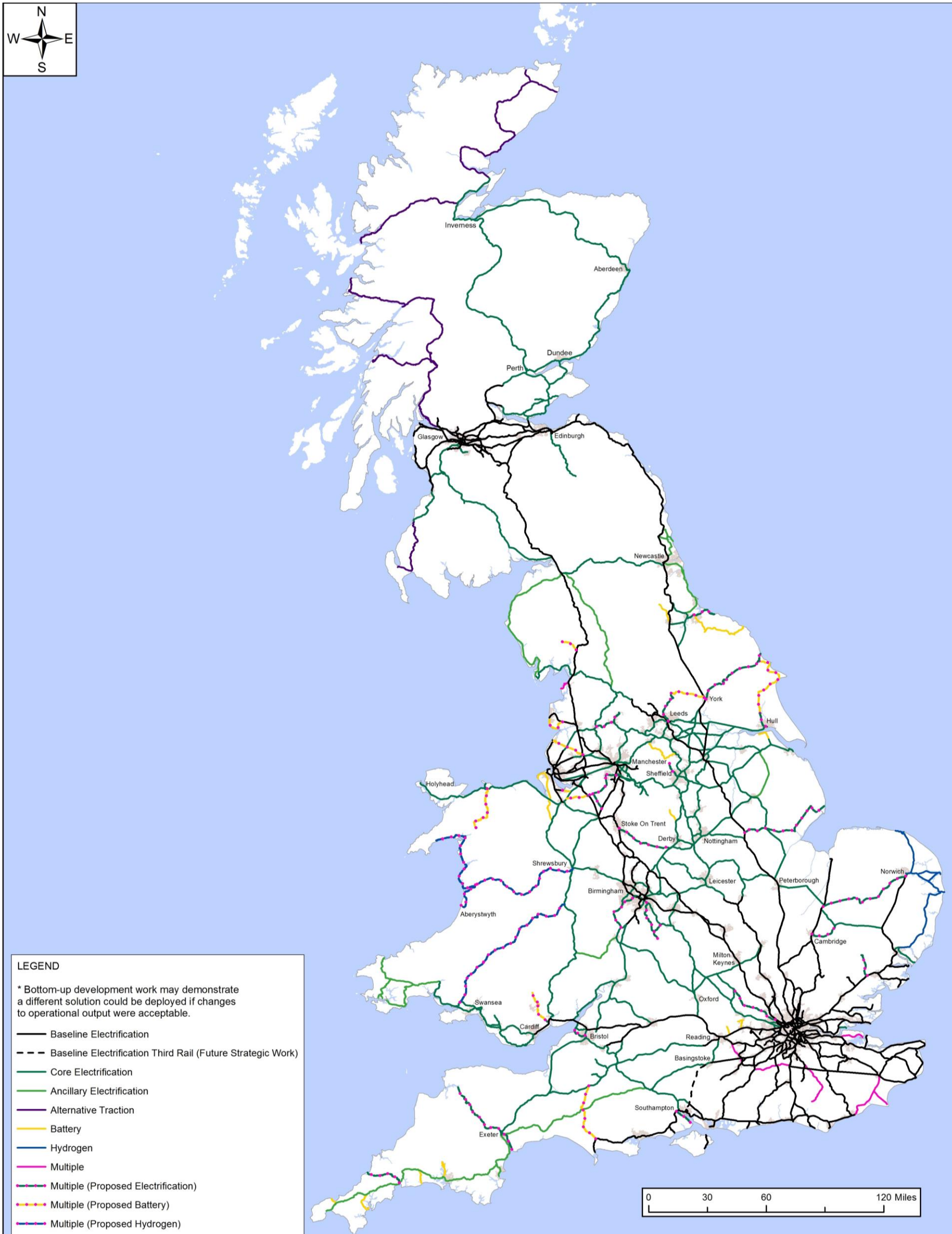

Figure 14: Recommended technology deployment to decarbonise the unelectrified UK railway

5.8.12 As well as the recommendations outlined over the previous sections, there are a number of other areas where careful consideration will need to be made in supporting wider traction decarbonisation. These areas are explored in more detail below.

EXTENSION OF THE EXISTING NETWORK

5.8.13 As part of the Budget announcement in March 2020 a fund was identified to support the reversal of Beeching closures of the railway which occurred during the 1960s and 70s. A number of proposed schemes are emerging which both utilise existing freight-only parts of the network or propose extensions beyond the railway's current geography.

5.8.14 It is critical that the proposals made are cognisant both of the recommendations made within this document and also of the net-zero emissions targets and the recommendations around transition to a zero-carbon railway.

5.8.15 It is recommended that any new railway being proposed considers the need to operate using zero carbon rolling stock (i.e. battery, electric or hydrogen), in conjunction with the wider network to which it is linked.

THE ROLE OF DIESEL ROLLING STOCK

5.8.16 As was outlined in section 5.6 there is a major role for diesel rolling stock in supporting the work needed to achieve interim emissions targets in advance of 2050. Hybridisation and the use of multi-mode trains offer an excellent opportunity to progressively realise both emissions reduction and the benefits of electrification and as such, whilst not an optimum long-term solution, should be considered in conjunction with the programme of electrification projects.

5.8.17 These vehicles are even more effective where they are reconfigurable and thus provide the flexibility to remove diesel generator sets or engines and replace these with a zero-carbon alternative.

5.8.18 Ultimately diesel cannot play any part in a zero-carbon railway and procurement of new diesel-only trains is likely to carry a significant volume of risk that they will be made redundant beyond 2050. Procurement of diesel-only units should only be pursued where there is a clear strategic and economic rationale for doing so.

LEARNING LESSONS FOR ALTERNATIVE TRACTION

5.8.19 Battery and hydrogen operations have a key role to play in traction decarbonisation. The introduction of new battery and hydrogen rolling stock and the infrastructure they will require will be complex and will require new standards, operating procedures and products. Whilst rolling stock technology is at a developed stage,

whole-system operational experience (i.e. infrastructure and rolling stock together) will be essential to inform the successful wider deployment of these technologies. As with any new technology introductions, there will be key lessons to be learned and embedded in operational best practice in advance of their wider roll-out. As a result, introduction of battery and hydrogen operations where this is the optimum solution ought to commence to ensure these key lessons are learned and embedded in advance of further deployments.

MODAL SHIFT

5.8.20 The role rail has to play in decarbonisation of the wider economy is clear. With rail currently being the only viable surface transport mode by which passengers and goods can be moved with a zero-emission solution, moving people and freight to rail is key. Whilst the DfT Transport Decarbonisation Plan will outline this in greater detail, projects and programmes which increase capacity would encourage modal shift to rail. This is especially the case for freight capacity projects where rail offers significant benefits compared with HGVs. All of these projects and programmes could draw on the strategic and economic benefits of decarbonisation and modal shift as part of their own business case.

EFFICIENT DELIVERY

5.8.21 The delivery of the recommendations made as part of this document will require significant investment in infrastructure and rolling stock and there may be efficiency and deliverability risks (associated with the level of disruption to the network) which challenge achieving the 2050 target date.

5.8.22 In order to ensure efficient delivery of traction decarbonisation a smooth and progressive programme is recommended whilst embedding lessons from previous activity. This programme is likely to include interim solutions to best use resources and keep disruption to the network to as low a level as possible, whilst realising reduction of emissions in line with targets. This programme will be considered as part of the TDNS Programme Business Case.

5.9 RECOMMENDATIONS – SCOTLAND’S RAILWAY

The work which has been led by Transport Scotland and Network Rail’s Scotland’s Railway region has been instrumental in establishing a long-term rolling programme of electrification for Scotland as outlined in the Transport Scotland Decarbonisation Action Plan.

The TDNS team has been working closely with colleagues from Scotland’s Railway and Transport Scotland to ensure the work presented in TDNS mirrors this plan which provides the rationale for the decarbonisation of Scotland’s domestic passenger services by 2035.

The remaining diesel services in Scotland will be those not within the direct control of Transport Scotland for cross border services from Scotland to the Midlands and South West as well as the major freight flows from Teesside and Felixstowe.

The DAP identifies “alternative traction” for the routes north west of Glasgow and north and west of Inverness and South of Girvan and a more detailed assessment will be needed to confirm the definitive approach to be adopted on these routes.

Together the Decarbonisation Action Plan and Traction Decarbonisation Network Strategy provide a clear picture of a zero emissions railway for Scotland.

A special thanks to colleagues in Transport Scotland and Scotland’s Railway Region for supporting TDNS to ensure the recommendations made by both nations are fully aligned and integrated.

5.10 RECOMMENDATIONS - EASTERN

The existing projects on the Midland Main Line and Transpennine provide a key delivery opportunity to provide further electrification of these routes. Continuation of current delivery will give a smooth programme of works that allows skills and experience to be retained for the large volume of electrification work required within the wider region. The deployment of further electrification in these areas is likely to feature as a high priority for delivery.

Freight flows feature heavily in recommendations from across the region, with major routes from Teesport, Felixstowe, London Gateway, Doncaster and Immingham all requiring electrification. This, coupled with major aggregates flows in West and South Yorkshire and the Midlands and the complexity of operations around the Leeds and Doncaster areas, means that overall a significant volume of electrification is required for freight. A number of the major routes from these ports and terminals see cross-

border traffic between Eastern and Scotland's Railway where decarbonisation targets are in advance of those in England and Wales and this will require consideration when programming the delivery of these schemes.

Equally prevalent are the long-distance high-speed operations of a number of operators. A notable focus here is on both the Midland Main Line, one of the last remaining long-distance high-speed routes to be operated using diesel traction, as well as the major CrossCountry flows from Scotland and the North East to the Midlands and the South and South West.

The complexity of operations and pathing and flighting of both passenger and freight services and the diversity of services using the wider Leeds Suburban network results in all of the wider Leeds suburban network being electrified. As an added benefit this will provide long-term air quality solutions for Leeds station itself, which is a major area of focus for local stakeholders.

Alternative traction is required for areas around the North East and the coastal areas of East Anglia. The intensive diagramming in both of these areas means the technology choice adopted will be critical and, especially for the North East, alternative arrangements may be needed until electrification roll out reaches a critical mass.

With the greatest extent of unelectrified network in the country, decarbonisation of traction within Eastern was always going to be complex and require significant volumes of both infrastructure and rolling stock. It is critical that the prioritisation and delivery of both electrification and alternative traction rolling stock is given detailed consideration.

As well as this there are a number of areas of key consideration for the Eastern Region.

- There are a number of major freight flows across the region, which will be critical in supporting decarbonisation of freight services in Scotland where the targets to achieve net-zero are in advance of those in England.
- Electrification of the Durham Coast would require careful consideration to ensure it aligns with Tyne and Wear Metro traction system and new rolling stock.
- East-West Rail infrastructure could be used in conjunction with Network Rail infrastructure to serve a key freight flow from Felixstowe to Oxford and beyond. If this emerged the section between Newmarket and Cambridge would need to be electrified to support these freight flows.

5.11 RECOMMENDATIONS - SOUTHERN

With a large proportion of the network in Southern electrified using the 750v DC third rail system the recommended deployment of 25kV in the Western parts of the region would introduce a novel technology for which new skills and experience in delivery and maintenance would either need to be developed or leveraged from Wales and Western Region or another third party. Further work will be needed to understand the impact of this with the option chosen to address this likely to be dictated by the volume of 25kV electrification to be delivered. As part of this, detailed consideration of the impact that 25kV OHL may have on isolation times and possession times will be needed as well as a careful assessment of the number of interfaces between AC and DC areas and how they could be managed.

Whilst not explored in detail as part of this work, more detailed consideration is required for the Southampton to Basingstoke corridor. As this route sees significant freight flow as well as long-distance high-speed trains operated by CrossCountry consideration of the use of third rail and the impact this could have are needed. This would need to consider all options including do-nothing with residual diesel emissions; enhancing the current flow of the third rail as was done in Kent to support heavy freight operations using third rail; or conversion to 25kV overhead line. Conversion to 25kV is likely to be costly, disruptive and time-consuming.

Further East the network within Sussex and Kent is slightly different. Providing a 25kV overhead line system on small sections between third rail infrastructure does not make operational sense. A piece of strategic work is currently underway between Network Rail, RSSB and the ORR to establish the feasibility of providing a modern-day conductor rail system for these areas. This will report in late 2021. If this work identifies the inability to deploy further third rail electrification it is likely that battery operation would be required to achieve a zero-carbon solution.

The role which third rail traction has to play in supporting freight services needs further investigation. Work undertaken in the Kent Route to increase current rates to support heavy electric freight traction using the third rail of services from the Channel Tunnel has shown the potential exists to utilise third rail, but areas where this enhancement is required need to be understood in conjunction with other options. Alongside this, the potential need to deploy AC/DC electric locomotives and the commercial impact this may have on freight operations will require careful consideration. If a solution cannot readily be found and delivered this means there is a potential risk of residual diesel emissions from freight in the Southern region if diesel-electric bi-mode locomotives have to be deployed.

5.12 RECOMMENDATIONS – WALES AND WESTERN

There are a number of complex freight movements from quarries, wharfs and ports in the Wales and Western region, including some of the heaviest freight trains on the network. These flows often travel significant distances with a number of flows from Wales and Western to Scotland where the targets to achieve net-zero are in advance of those in England. Freight flows from South Wales in particular are numerous and travel to destinations well beyond the region resulting in a number of areas of electrification outlined within this document.

Long-distance high-speed operations beyond the extent of the recently commissioned electrification will require extension including beyond Cardiff and Bristol.

CrossCountry long-distance high-speed services from the West Midlands to the South West and South Coast alongside the major freight flows leads to a number of routes requiring electrification.

The recent completion of the electrification programme within the area means there are a number of experienced delivery personnel who could readily support the efficient delivery of further electrification work. These skills will begin to be lost if work is not undertaken in a timely manner. It is envisaged that further proposed electrification in these areas would be a high priority in order to support this.

A large number of diversionary routes exist both in Wales and Western routes that are utilised by both passenger and freight services and careful consideration will have to be given to these.

The deployment of alternative traction is principally focused around the Devon and Cornwall branch lines as well as the regional routes in central Wales, with battery and hydrogen both required.

5.13 RECOMMENDATIONS – NORTH WEST AND CENTRAL

A number of freight flows converge within the North West and Central Region, and with the WCML being one of the heaviest freight corridors in the UK, freight routes within this region are critical. Flows from the South Coast, South Wales and Western all converge in the key network nodes of Birmingham and Crewe, and with Nuneaton playing a major role in both North-South and East-West flows from Felixstowe in Eastern the extent of electrification required for freight is significant.

Similarly, a number of CrossCountry passenger flows converge and diverge in the Birmingham and Manchester areas. This, coupled with the long-distance flows between London and Birmingham via the Chiltern Main Line, results in complementary and further electrification to support these services as well as the extensive volume of freight services which use these routes. Increasing this electrification north of Birmingham Snow Hill and including branches to Aylesbury and Stratford-Upon-Avon would allow wider fleet homogeneity and provide greater flexibility. This should be considered for delivery in tandem with electrification of the Chiltern Main Line. Operations beyond the existing WCML network to Shrewsbury and North Wales also result in further electrification.

The wider suburban networks around Manchester and Liverpool benefit from electrification due to the complex passenger and freight flows that operate across these corridors. Routes into Manchester via the Castlefield corridor would especially benefit from electrification, which would allow an improved uniformity of service through this corridor as opposed to the mixture of diesel and electric as seen today. This and a number of other interventions, will play a significant part in the emerging Manchester Rail Strategy.

The existing electrification projects in the North West and Transpennine provide a key delivery opportunity to provide further electrification of these routes. Continuation of current delivery will give a smooth programme of works that allows skills and experience to be retained for the large volume of electrification work required within the wider region. The deployment of further electrification in these areas is likely to feature as a high priority for delivery.

On the assumption that East-West Rail will be electrified to some extent, whilst noting this is not currently committed, there would be a long-term need to have the wider route electrified beyond the current East-West Rail route. This will be essential if freight services from Felixstowe to the West are to be accommodated.

With a number of shorter branch lines, most routes not provided with electrification are most likely to utilise battery operation.

5.14 TRACTION DECARBONISATION PROGRAMME

5.14.1 The intention of both this TDNS Interim Programme Business Case and the further TDNS Programme Business Case to be issued later this year is to outline the proposals to achieve traction decarbonisation. Significant follow-up work will be required to realise the delivery of these recommendations.

5.14.2 The delivery of this “Traction Decarbonisation Programme” will be outlined in the programme of decarbonisation section included as part of the Management Case.

5.14.3 A number of strategic assumptions have been made as part of the Traction Decarbonisation Network Strategy deliverables alongside a number of key strategic risks and opportunities which have been identified. These are summarised in Appendix 9.

5.15 STRATEGIC CASE: CONCLUSION

Climate change is a global issue which poses a significant threat to humanity and the ecosystems in which we live. This has been recognised at a global scale through the introduction of the Paris Climate Agreement which has established a binding target to limit the impacts of global warming and the associated climate change implications.

The UK government has responded to this obligation by becoming one of the first governments in the world to establish a legally binding net-zero emissions target. Achieving this target will require significant investment across the economy.

Whilst rail currently contributes only a very small amount of the national annual greenhouse gas emissions, it has an important role to play. Rail is one of the greenest modes of transport for both people and goods and can offer support in decarbonising the wider surface transport sector in the UK through modal shift to rail. Where this modal shift occurs to a zero-emissions rail network the benefits will become even greater.

Traction emissions from diesel trains are the largest contributor to rail’s annual emissions and if rail is to become a zero-emissions transport mode diesel must be removed and replaced with other technologies. The economic case will begin to outline these possible solutions in greater detail.

The removal of diesel trains not only provides the primary benefit of reducing rail’s contribution to greenhouse gas emissions, but also has the potential to bring several significant secondary benefits. The six key areas which have been outlined in this strategic case present these primary and secondary benefits of traction decarbonisation.



Three principal solutions exist for decarbonisation of traction within rail: battery, electrification and hydrogen. These three technologies have been described and, based on their technical capabilities, areas of the network where they are suitable for deployment have been established.

This has resulted in the recommendation of:

- c. 11,700 STKs of electrification for long-distance high-speed passenger and freight services;
- hydrogen train deployment over c. 900 STKs of infrastructure;
- battery train deployment over c. 400 STKs of infrastructure; and
- 2,400 STKs where a single technology is not immediately clear.

Of this 2,400 STKs further analysis suggests the deployment of:

- a further c. 1,340 STKs of electrification;
- hydrogen train deployment over c. 400 STKs of infrastructure;
- battery train deployment over c. 400 STKs of infrastructure; and
- there remains 260 STKs where a technology choice is yet to be made.

Whilst these recommendations are extensive there are a number of areas where freight services would operate beyond the proposed electrification. Modelling suggests this residual emission to be around 50 million kgCO_{2e} per year (this is around 3% of today's total traction emissions). The residual emissions from these remaining services would either need to be offset or removed using an alternatively fuelled freight locomotive (which is not currently available in the UK) in order to remove the requirement to electrify almost all of the network.

The extent of the deployment of these technologies has been illustrated using maps with summaries provided for each of the Network Rail regions and a national perspective.

The economic case explores the costs and benefits associated with the technology recommendations made as part of this strategic case, outlining the order of magnitude costs and benefits for these. Whilst the focus of this document is not the commercial, financial or management aspects of traction decarbonisation, (as these will be contained within the TDNS Programme Business Case to be issued in October 2020) the initial areas of focus are outlined and summarised following the economic case.

6. ECONOMIC CASE

6.1 ECONOMIC CASE: SUMMARY

As has been outlined in the strategic case, whilst rail's overall contribution to UK emissions as a whole is small, the opportunities for rail to support wider transport decarbonisation are clear, especially where a decarbonised rail network is provided. Current rail traction related emissions from the UK rail network total approximately 1.8 billion kgCO₂e per year¹³⁵. Building on the work presented in the strategic case, the economic case considers the economic impact of eliminating these rail related emissions and provides an indicative assessment of the net economic value from different approaches towards meeting this goal.

The results presented in the economic case establish an initial, nationwide view of the potential order of magnitude of costs and benefits from the recommendations outlined in section 5.8. It should be stressed that this analysis provides an initial, limited view of benefits and costs and has been based on a number of assumptions that carry limitations and caveats which are outlined in section 6.8. The analysis has been provided to enable further discussions on the decarbonisation of traction power. This case outlines this initial analysis providing:

- economic results which indicate the potential of long-term value from pursuing rail enhancement schemes which seek to decarbonise parts of the network;
- demonstration of economic impact from different pathways for traction decarbonisation;
- identification of key areas of uncertainty in economic costs and benefits; and
- identification of the key interactions between economic value and the strategic, commercial, financial, and management cases.

The economic case has tested multiple pathways for reducing rail emissions to between 19 and circa 300 million kgCO₂e per annum, with end realisation dates ranging between the years 2040 and 2068.

The resulting Net Present Value (NPV) to the economy ranges between £-3.7bn to £1.6bn (2010 PV) for the tested pathways, observed over an appraisal period between

¹³⁵ TDNS modelled figures for 2019/20 calibrated using ORR 2018/19 figures

2020 and 2110. In most pathways, this represents net value to the UK economy over the next ninety years.

6.2 INTRODUCTION

- 6.2.1 The rationale for decarbonising traction power on the UK rail network has been comprehensively outlined within the strategic case. The economic case is focussed on understanding the trade-offs that are likely to be involved in following different decarbonisation pathways to achieve the recommendations outlined in section 5.8.
- 6.2.2 The core output of the economic case is a comparison of economic value that could be derived from different implementation approaches for these recommendations, compared with a base case of no future traction decarbonisation. The aim has been to capture all the relevant impacts and present them in as balanced a way as possible, highlighting caveats to the analysis where necessary and signposting clear strategic choices wherever possible. Likewise, while efforts have been made to ensure that the analysis is as comprehensive as possible, a number of simplifying assumptions have been used to differentiate between the different pathways.
- 6.2.3 Unlike most traditional economic cases provided to funders, this analysis is not designed to inform a single identifiable investment decision. Instead, it is intended to set the strategic direction of travel for the industry in an important area of policy over the next thirty-years. The economic case therefore follows the Department for Transport's Transport Appraisal Guidance (TAG) guidance but contains a few key exceptions where appropriate. These have been agreed by key stakeholders as part of this initial analysis and will be kept under review. These variations are explained where they occur.
- 6.2.4 Rail projects established with the purpose of decarbonising transport will in some instances have a far broader scope than simply decarbonising traction. This will become more relevant as projects are developed which build on the TDNS. It is important to note that the economic analysis provided as part of this appraisal only considers costs and benefits associated directly with interventions required to achieve traction decarbonisation.

MEASURES OF SOCIO-ECONOMIC VALUE

- 6.2.5 In traditional rail business cases, cost-benefit analysis (summarised by a benefit-cost ratio (BCR)) is often used. The use of a BCR is of limited use (and potentially misleading) in this economic case due to the programmatic nature of the

interventions with no clear start year or total duration and benefits realised progressively. For this reason, the Net Present Value (NPV) is employed in conjunction with a measure of cost-effectiveness.

- 6.2.6 Additionally, value-for-money estimates for electrification schemes in particular can be sensitive to relatively small changes in cost due to the way benefit-cost ratios are calculated as a significant amount of cost and “benefit” are recorded as capital costs or operational cost savings.
- 6.2.7 For these reasons, Net Present Values (NPVs) – which are less subject to volatility are employed in conjunction with a measure of cost-effectiveness.
- 6.2.8 Cost-effectiveness is a measure of efficiency in terms of meeting a quantifiable objective for example, the economic cost of reducing emissions of a tonne of CO₂e. It is appropriate in this instance to employ cost-effectiveness because it is relatively easy to apply across all transport modes and is therefore a useful comparator for investment between different modes of transport.

SCOPE OF COST AND BENEFIT ANALYSIS

6.2.9 The strategic benefits (including non-quantified benefits) were outlined in detail in section 5.5 of the strategic case and an overview of the relationship between these and the benefits considered within this economic case is summarised in Appendix 5. The economic benefits quantified within this appraisal are shown below.

- **Carbon reduction benefits** – the value of reduced CO₂e emissions emitted into the atmosphere from passenger and freight trains.
- **Journey time benefits** – the value of journey time savings from improvements in rolling stock acceleration and deceleration.
- **Performance benefits** - the value of more reliable passenger journeys due to improved reliability of non-diesel passenger and freight rolling stock.
- **Road decongestion benefits** – the value of marginal reduction in congestion on the road network, driven by abstraction of demand from road to rail. This delivers road decongestion benefits, reductions in road accidents, reductions in road maintenance costs, improved air quality around roads, and reduced noise pollution. These benefits are partly offset by the reduced taxation income from road users.
- **Passenger revenue** – additional journeys stimulated by a more attractive journey time, in addition to reliability improvements.

6.2.10 The extent of the recommendations outlined within section 5.8 will clearly require a significant amount of both upfront capital investment and also ongoing operational costs for rolling stock and infrastructure as well as disruption dis-benefit during construction. The costs and dis-benefits quantified within this appraisal are shown below.

- **Infrastructure capital and renewal costs** – a range of capital and renewals expenditure over time, reflecting the cost of overhead electrification, hydrogen refuelling points, and battery charging points.
- **Infrastructure maintenance costs** – the increased maintenance cost of additional overhead line.
- **Disruption during construction disbenefits** – the costs of increased passenger journey times from reduced rail services during the construction period for new or enhanced rail infrastructure.
- **Rolling stock maintenance costs** – changes in maintenance costs according to mileage covered by each rolling stock type in operation in the passenger timetable.
- **Rolling stock fuel costs** – changes in fuel costs according to mileage and consumption rate covered by each rolling stock type in operation in the passenger timetable.
- **Rolling stock lease costs** – changes in lease costs due to the different rolling stock in operation in the passenger timetable.
- **NR maintenance costs** – changes in track maintenance costs and electrical asset maintenance costs due to the mileage covered by each rolling stock type in operation in the passenger timetable.

6.2.11 Costs attributable to the private sector are not included in the economic analysis as these are outside of the scope of a TAG compliant appraisal. Direct upfront capital costs for passenger rolling stock, freight locomotives and rail freight operations costs are excluded from the economic appraisal in line with appraisal guidelines and are discussed in greater detail within the financial case.

6.3 PATHWAYS APPRAISED

ESTABLISHING A BASELINE – THE DO-MINIMUM

6.3.1 The economic efficiency of each option is discussed in comparison with a baseline position. The baseline position is the assumed state of the network and the services operating on it at a point in time in the near future. It is important

to note that the baseline position is not intended to reflect the state of the network and the state of services in their present position, i.e. it is not a “do-nothing” position.

- 6.3.2 Rather, it is a position which takes account of future investments and commitments which the governments have made, but which have yet to be delivered.
- 6.3.3 The assumptions developed for the do-minimum have been done so in collaboration with funders and key stakeholders to reflect a realistic view of current commitments.
- 6.3.4 The material assumptions contained within the do-minimum are shown below.
- **Start year timetable** – passenger services are assumed to run according to the weekday May 2019 timetable. Freight services are assumed to run according to the pattern of services observed between period 9 (P09) 2018/19 and period 4 (P04) 2019/20, pro-rated to a whole year.
 - **December 2019 timetable changes** – passenger services in the May 2019 timetable running on diesel traction power, but intended for operation with an IET, have been allocated to an appropriate diesel electric bi-mode rolling stock.
 - **HS2** – HS2 Phase 1, 2a and 2b will be delivered as per the current delivery timetable and the current parliamentary powers.
 - **Post HS2 timetable** – the post-HS2 Phase 2b timetable is assumed to be delivered by 2037¹³⁶. Indications at this stage suggest this will introduce a number of new services on the conventional network as capacity is reallocated. Indications are that this would increase mileage on currently non-electrified routes particularly in the north of England. Demand impacts to the conventional network associated with the HS2 Phase 2B have not been modelled as part of this analysis due to the complexity of modelling this.
 - **Core Valley Lines** - these transitioned in ownership on 28th March 2020 from Network Rail to the Welsh Government through their transport authority, Transport for Wales. TfW infrastructure has outlined proposals to partly electrify this infrastructure and operate electric/battery tram-train vehicles. For the purposes of the do-

¹³⁶ <https://www.parliament.uk/business/publications/written-questions-answers-statements/written-statement/Commons/2019-09-03/HCWS1809/> - Written Statement from the DfT Secretary of State, 03 September 2019 – “He expects Phase 2b, the full high-speed line to Manchester and Leeds, to open between 2035 and 2040”

minimum baseline it is assumed that this is a committed scheme and that these services will be operated using decarbonised traction. Services in operation only on the Core Valley Lines have been excluded from the analysis.

- **Other schemes** - Several projects with decarbonisation elements within them are currently progressing through the RNEP (England & Wales) and RECI (Scotland) processes but are yet to have reached a decision based on a Full Business Case. These projects have not been included in the do-minimum assumptions.

TRACTION DECARBONISATION PATHWAYS

- 6.3.5 The pathways under consideration have been developed to highlight the key trade-offs which funders will need to consider depending on the extent and pace at which the recommendation made within section 5.8 could be delivered.
- 6.3.6 Each of the pathways will carry different levels of feasibility, with this considering many different aspects (commercial, financial, and management) that will determine an overall view of the feasibility of their implementation. There will be a number of potential trade-offs to be considered, including for instance, higher single track kilometre (STK) delivery rates for electrification which would subsequently change the spend profile over time.
- 6.3.7 Five primary decarbonisation pathways have been identified for appraisal at this stage. These are shown alongside the do-minimum in Table 4 overleaf.

Pathway	Ambition	Aspiration for each modelled Pathway
Do-minimum	None	No changes to the current status of the railway except for the operational impact of the post HS2 Phase 2b timetable change on the conventional network.
Pathway 1	Low	The do-minimum plus a decarbonisation strategy that achieves an 80% reduction in traction power carbon emissions from 2019 levels. ¹³⁷
Pathway 2	Low-Medium	The do-minimum plus a decarbonisation strategy that achieves an 95% reduction in traction power carbon emissions from 2019 levels. ¹³⁷
Pathway 3	Medium	The do-minimum plus a decarbonisation strategy that achieves Net-Zero carbon emissions for traction power from 2019 levels by 2050.
Pathway 4	High	The do-minimum plus a decarbonisation strategy that achieves Net-Zero carbon emissions for traction power from 2019 levels by 2040.
Pathway 5	Medium	The do-minimum plus a decarbonisation strategy that achieves Net-Zero carbon emissions for traction power from 2019 levels by 2061.

Table 4: Traction decarbonisation pathways modelled within the TDNS economic model.

- 6.3.8 At this stage a programme of decarbonisation to deliver the recommendations outlined in section 5.8 has not been fully established and this will be a principal focus of the TDNS Programme Business Case to be provided in October 2020.
- 6.3.9 For the purposes of economic modelling only indicative programmes have been established for the pathways outlined above based around carbon reduction prioritisation and known stakeholder priorities.
- 6.3.10 Working with industry stakeholders, a more detailed programme of decarbonisation will be developed, which will subsequently be modelled as part of the TDNS Programme Business Case. The recommendations outlined previously indicate a significant volume of electrification is required to achieve traction decarbonisation and this forms the majority of the indicative programmes established for the relevant pathways.

¹³⁷ These pathways only introduce enough of the recommendations outlined in the strategic case to achieve 80% and 95% tailpipe emissions reduction respectively.

6.3.11 Table 5 below identifies the average STK electrification delivery rate over the relevant pathway programmes as well as identifying the largest single year maximum within the programme.

Traction Decarbonisation Pathway	Average Annual STKs over programme	Maximum STKs in any one year
Pathway 1 (-80%)	259	377
Pathway 2 (-95%)	303	447
Pathway 3 (Net-Zero by 2050)	355	691
Pathway 4 (Net-Zero by 2040)	658	922
Pathway 5 (Net-Zero by 2061)	303	447

Table 5: Indicative electrification infrastructure volumes from economic pathways

6.3.12 As outlined, these programmes are indicative, and work will be undertaken between network Rail and the wider industry in conjunction with RIA and the industry supply chain to provide a more detailed programme of decarbonisation in the full TDNS Programme Business Case. This is explored in greater detail in Section 7.3.

6.4 ECONOMIC APPROACH

LENGTH OF APPRAISAL

- 6.4.1 A key consideration for the work undertaken has been the appraisal period. Under TAG guidance, a sixty-year appraisal period is the standard assumption in a rail project. This appraisal length is based on asset life (civil engineering assets such as embankments and bridges have long asset lives, whereas assets such as rolling stock and signalling have much shorter asset lives). In addition, the opening date of a project (i.e. the date from which economic benefits would be expected to accrue to the funder) tends to be in the near future in a typical infrastructure project appraisal.
- 6.4.2 In a longer-term programme such as the TDNS, where project opening dates are numerous and potentially stretch up to and beyond 2050, the rationale for a 60-year appraisal is less clear. This is because it would significantly foreshorten the modelled asset lives of the later projects within the programme, thus failing to capture the significance of such a transformational long-term infrastructure investment in the appraisal.
- 6.4.3 Where capital costs are significant (as is the case in the TDNS programme), an investment will tend to yield a higher NPV over a longer appraisal period purely because this allows a longer period of time for the scheme to “pay back” the

initial capital costs, either in terms of economic benefits or a reduction in operating costs (or a combination of the two).

- 6.4.4 In line with UK Green Book evaluation guidance¹³⁸ the analysis undertaken for TDNS is based on much longer appraisal periods stretching up to 2110, allowing a 60 year window to account for benefit and cost impacts from delivery of infrastructure as late as 2050, which represents the median date for when the modelled pathways complete the delivery of infrastructure. This approach has been agreed with the DfT.

GROWTH

- 6.4.5 The benefits associated with decarbonising railway traction are to some degree a function of the number of passenger and freight journeys that are made by rail. Likewise, the number of journeys that are made by rail is to a large degree a function of so-called 'exogenous' demand drivers. Exogenous demand drivers are factors that influence the demand for travel that are outside the control of the rail industry. Examples of exogenous demand drivers are population and employment.
- 6.4.6 Given that the timescale of the TDNS programme is relatively long, estimates of growth for exogenous factors are necessarily subject to significant uncertainty even without considering how behavioural assumptions could affect how these factors are translated into rail demand. Not only are aggregate growth rates subject to this uncertainty, there is likely to be significant inter-regional variations that could lead to significantly different outcomes for regional demand drivers.
- 6.4.7 However, the strategic objective of the TDNS is to decarbonise railway traction rather than to provide an appropriate level of capacity to satisfy a given level of growth (or reduction) in demand.
- 6.4.8 For this reason, the growth rates are applied to the first 20 years of the appraisal period, 2020 to 2039¹³⁹, after which population growth is applied in compliance with TAG¹⁴⁰. These growth rates are shown in Table 6 overleaf.

¹³⁸ HM Treasury, 2020, The Green Book, p.24.

¹³⁹ EDGE April 2020 passenger journeys growth for all flows

¹⁴⁰ Although the TDNS covers the whole of the GB network including Scotland, it should be noted that it follows the DfT's appraisal guidance. For the most part, the relevant assumptions informing the model are identical. The only substantive difference between the Scottish Transport Appraisal Guidance (STAG) and TAG is the demand cap. In Scotland, the demand cap is applied in 2032 whereas TAG applies a twenty-year cap. A separate analysis will be provided for Scotland in the Programme Business Case.

Parameter	CAGR
Passenger growth assumed from 2020 to 2039	1.04%

Table 6: Exogenous growth

6.4.9 It should be noted that for other, broader elements of transport decarbonisation, capacity discussions (and therefore discussions relating to demand growth) will clearly be more relevant: the narrow scope of the TDNS mean that its economic case is far less sensitive to growth assumptions than it would be with broader transport decarbonisation objectives.

6.4.10 Considerations of passenger crowding effects are therefore excluded from the analysis at this stage. It is expected that the relative impact these would have on the estimation of passenger benefits and revenue at this stage are small compared to the overall impact of passenger journey time savings and performance improvement.

KEY APPRAISAL PARAMETERS

6.4.11 The key appraisal parameters for the modelled pathways is summarised in Table 7 below.

Appraisal period	90 years
Discount rate	3.5% for years 1-30; 3.0% for years 31-60; and 2.5% for years 61-90.
Appraisal base year	2020
Appraisal price base year	2010

Table 7: Key appraisal parameters for all modelled pathways

6.4.12 The remainder of this section outlines the approach taken for capital cost, operational costs and economic benefits.

CAPITAL COSTS

6.4.13 The majority of capital cost expenditure in each of the pathways arises from the cost of overhead electrification and associated works required to deliver this. The cost of battery charging points and hydrogen refuelling make up the

remainder of capital costs and are comparatively smaller due to the size of deployment recommended.

- 6.4.14 The capital costs included as part of this appraisal comprise only of the costs required to be able to deliver electrification, battery and hydrogen trains. For many areas of the country when electrification especially is being delivered, there may be efficiencies and benefits in delivering other renewals and/or enhancements work at the same time, for example track renewals, signalling replacement (deployment of ETCS) and capacity enhancements.
- 6.4.15 The costs and benefits of any works beyond those required for the core decarbonisation programme are not included in the economic assessment within this analysis and would be identified by development of business cases for individual programmes of work to inform funding decisions made through Investment Decision Framework.
- 6.4.16 For this appraisal, capital costs were estimated by dividing the unelectrified rail network into 151 segments with each assigned a cost rate for a single-track kilometre of electrification based on their complexity. Complexity has been assessed using the range of criteria outlined below to assess complexity:
- length of segment;
 - complexity of civil engineering (i.e. considering the number and nature of bridges and tunnels on the segment);
 - economic cost of disrupting traffic on the segment; and
 - likely project duration.
- 6.4.17 Complexity scoring has been jointly agreed with Network Rail regional representatives.
- 6.4.18 Capital costs at this stage have been estimated using a wide total cost bracket spanning from £1m/STK to £2.5m/STK (2020 prices). These costs are based on historical project outturn costs rather than estimates. More information on this is provided in section 8.2.
- 6.4.19 Capital cost of battery charging points and hydrogen refuelling locations were determined using preliminary estimates from RSSB's T1199 project. These costs were then scaled according to the number of battery and hydrogen multiple units required to operate the defined segments of the network.
- 6.4.20 The capital costs for electrification, battery and hydrogen were then profiled over time according to the relevant pathway programme outlined in section 6.3.

- 6.4.21 The capital cost estimates for each pathway are presented as a range, to reflect the uncertainty in the complexity and corresponding approach towards delivering OLE.
- 6.4.22 Applying optimism bias to TDNS costs would not be appropriate because the capital costs used in the analysis are presented as a range rather than as a central estimate. This cost range reflects the known uncertainty at this stage. This approach has been agreed by all stakeholders. The projects which are developed as a result of the TDNS may be broader in scope than just traction decarbonisation but this additional scope (which will be the source of additional cost and benefit) is outside of the scope of this appraisal.
- 6.4.23 This choice avoids the conflation of the uncertainty in STK rate cost with the uncertainty expected from with typical rail project appraisals at early GRIP stages. TDNS faces a series of risks and uncertainty on a much larger scale compared with a typical enhancement scheme, and as such, careful consideration of how these translate into an economic case requires further investigation.
- 6.4.24 As they are developed, enhancement projects which have rail traction decarbonisation as a component will need to have optimism bias applied as per the TAG guidance.
- 6.4.25 Capital cost savings may be possible through the deployment of discontinuous or discrete electrification where this is operationally possible. The decisions behind deploying such a solution are localised and as outlined in section 5.6, and will require consideration in specific project business cases where more detailed development work is completed.

OPERATIONAL COSTS

- 6.4.26 An operational cost model has been used to determine changes in passenger rolling stock costs, carbon emissions, and rolling stock reliability in response to changes in infrastructure inputs. In addition, carbon emissions from changes in freight rolling stock have also been estimated in response to the same infrastructure inputs. The measures considered in the operational cost modelling are set out overleaf in Table 8.

Measure	Unit	Passenger/Freight services
Rolling Stock Reliability	km per technical incident	Passenger & Freight
Electricity Consumption	Million kWh per year	Passenger
Diesel consumption	Million litres per year	Passenger ¹⁴¹
Hydrogen consumption	Million kg per year	Passenger
Carbon emissions by Electricity (affected by grid mix assumptions)	Million kgCO ₂ e per year	Passenger & Freight
Carbon emissions by Diesel	Million kgCO ₂ e per year	Passenger & Freight
Carbon emissions by Hydrogen	Million kgCO ₂ e per year	Passenger
Maintenance costs	£m per year	Passenger
Track Access Charges	£m per year	Passenger
Electricity Access Charges	£m per year	Passenger
Estimated Lease Costs	£m per year	Passenger

Table 8: Components of operational cost calculations within TDNS

6.4.27 The sources of capital and operational aspects considered within the economic model is summarised in Appendix 10.

6.4.28 Using the infrastructure identified as part of section 5.8 and the delivery programmes developed for each modelled pathway, a level of network capability to operate non-diesel traction was determined for a series of defined future years, and provided as an input into the operational cost model. The individually modelled years are set out overleaf in Table 9.

¹⁴¹ The fuel consumption of freight trains is also estimated in the modelling, but the costs associated with this are excluded from this appraisal.

Modelled Year	Rationale
2019/20	Base Year used for calibration
2027/28	End of 4 th Carbon Budget
2032/33	End of 5 th Carbon Budget
2037/38	End of 6 th Carbon Budget
2050/51	Aspirational date to achieve zero carbon
20XX/XX	Additional year to model the final state of each pathway. The year modelled varies by pathway.

Table 9: Modelled years

6.4.29 The operational cost model was then used to determine how to make changes in rolling stock allocation in the do-minimum, replacing diesel rolling stock on passenger and freight services as and when future infrastructure states made this possible in each pathway. On the basis of these amended rolling stock allocations, modelled estimates for each of the metrics listed in Table 8 were produced. A profile of future costs and carbon emissions were then created by interpolating the results in each modelled year.

ECONOMIC BENEFITS

6.4.30 Passenger benefits and revenue were estimated for journey reliability improvements and journey time improvements corresponding to rolling stock changes.

6.4.31 Using the changes in rolling stock allocation to passenger and freight services in the operational cost calculation stage, a summary of rolling stock reliability and unit kms by traction power was produced. These metrics were calculated on a service code level (there are just over 400 of these) and used to estimate changes in average passenger lateness and total passenger journey time for each service code. These calculations were based on upon the assumptions in Table 10, Table 11 and Table 12 overleaf.

% of Delay Minutes corresponding to rolling stock reliability	Source
30%	Total of 701D delays as a proportion of all delays to passenger services in the 2 years to 2019/20_P02

Table 10: Performance assumptions

Change in traction power	% of reliability improvement transmitted to passenger (account for a corresponding increase in OLE related delays).
Diesel to Electric	60%
Diesel to Hydrogen	100%
Diesel to Battery	100%

Table 11: Performance Assumptions

	Diesel -> Electric Traction	Diesel -> Hydrogen Traction	Diesel -> Battery Traction
Average JT Saving vs Diesel - Short Distance	-7.2%	-6.8%	-6.8%
Average JT Saving vs Diesel - Long Distance	-1.2%	-1.0%	-1.0%
NB: % JT improvements were deduced based on Capability Analysis assessment of a short-distance journey of 31KM and a long-distance of 179KM			

Table 12: Journey time savings assumptions

6.4.32 The estimated change in passenger lateness and journey times were then used to estimate an increase in passenger numbers, using Passenger Demand Forecasting Handbook (PDFH) methodology, as faster and more reliable journeys attract additional customers. Based on these increases in demand, a corresponding increase in passenger revenue was calculated, along with a decrease in road congestion levels which are classed as non-user benefits.

6.4.33 Crowding effects were not considered as part of this appraisal as the impact of inclusion would be disproportionate to the complexity of the analysis required at this stage.

6.4.34 It should also be noted that additional upside considerations such as a reduction in the number of electric vehicles to operate a comparative diesel service has also not been taken into account at this stage of the analysis.

6.5 ECONOMIC OUTPUTS

6.5.1 As discussed in section 6.2, the analysis in this economic case differs from a typical TAG compliant appraisal, and as such, a Benefit to Cost Ratio (BCR) is not provided in the results. The more appropriate measures of Net Present Value (NPV) and a Cost Effectiveness Indicator (CEI) are used to assess the value delivered by each of the different pathways.

6.5.2 The NPV summarises the net increase in economic welfare to the UK economy over the span of the appraisal period. A Net Present Value analysis can yield either a positive or a negative result. This indicates whether or not the investment implied by an investment pathway yields a net return to the economy during the appraisal period.

6.5.3 Present Value of Benefits (PVB), Present Value of Costs (PVC) and Revenue are the summary of benefits and costs of the scheme in terms of their overall present day value to the economy. These values are then used to calculate the NPV such that:

$$NPV = PVB - PVC$$

$$\text{Where: } PVC = \text{Costs} - \text{Revenue}$$

6.5.4 Note that the PVC is shown as a range to reflect high and low capital cost estimates of each pathway. These capital costs are also used to estimate the compensation to train operators for disruption during construction, and therefore the compensation to passengers during disruption which is captured in the PVB. The PVB is therefore shown as a range, although much smaller compared to the range in PVC.

6.5.5 The CEI evaluates the cost to the economy (in terms of £ per CO₂e avoided) of reducing future emissions for each investment pathway. As well as enabling the pathways to be compared, this measure of cost effectiveness is likely to provide a point of comparison against analysis of other transport modes. This is expected to be undertaken as part of the Department for Transport's wider Transport Decarbonisation Plan (TDP).

6.5.6 Across the appraisal period from 2020 to 2110, a total of circa 100–140 billion KgCO₂e is saved across each of the modelled pathways. The tailpipe emissions reduction pathways of each of the pathways is shown in Figure 15.

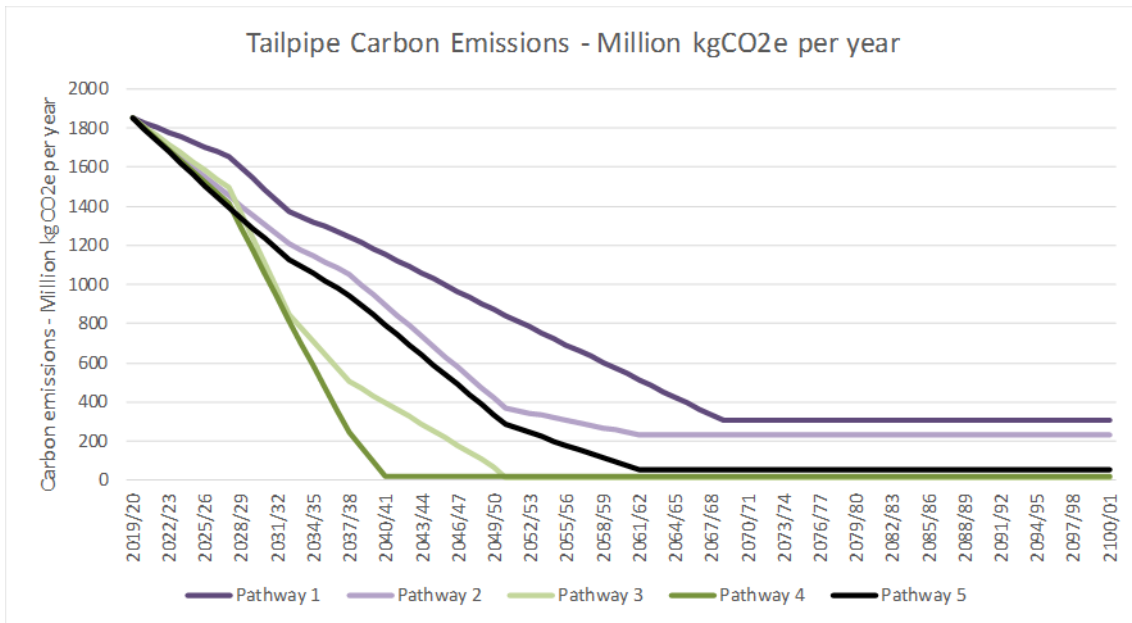

Figure 15: CO₂e tailpipe emissions reduction for TDNS modelled pathways

6.5.7 For pathways 3, 4 and 5 all passenger emissions are removed with the residual emissions beyond the relevant end dates a result of freight train operation over unelectrified segments of the proposed network. A mixture of engineering trains, yellow plant and general freight services operate over the segments not proposed for electrification. The residual emissions from these remaining services would either need to be offset, removed using an alternatively fuelled locomotive or by providing further electrification. Providing electrification in order to remove these services would require an additional 2,100 STKs of electrification with a capital cost increase of £3bn-£4bn (2020 prices). This has not been modelled as part of this appraisal.

6.5.8 The value ranges for each of the modelled pathways for these factors and a summary of the CEI is provided in Table 13 overleaf.

	Pathway 1	Pathway 2	Pathway 3	Pathway 4	Pathway 5
Description	80% reduction	95% reduction	Net-Zero by 2050	Net-Zero by 2040	Net-Zero by 2061
Million KgCO ₂ e saved	-97,000	-110,000	-129,000	-132,000	-121,000
Present Value of Benefits (PVB) (£m 2010 PV)	£4,700 to £5,000	£5,700 to £6,000	£6,900 to £7,300	£7,100 to £7,600	£6,500 to £6,800
Present Value of Costs – Revenue (PVC) (£m 2010 PV)	£4,800 to £7,300	£5,200 to £7,900	£6,300 to £9,700	£7,200 to £10,900	£5,200 to £8,100
Net Present Value (£m 2010 PV)	-£2,500 to £300	-£2,200 to £800	-£2,800 to £1,000	-£3,700 to £400	-£1,600 to £1,600
Cost Effectiveness Ranking (using £/CO ₂ e removed)	£33 to £62	£30 to £57	£30 to £59	£35 to £66	£23 to £51

Table 13: Summary of NPV and CEI for TDNS modelled pathways

6.5.9 The NPVs for each pathway are shown as a range, with pathways 2, 3 and 5 resulting in the higher NPVs. This is also reflected in the cost effectiveness indicator, which show them to be the most cost efficient of the five appraised pathways.

6.5.10 The relationships between costs and benefits over time and how they interact to form the NPV for Pathway 3 are shown in Figure 16 below.

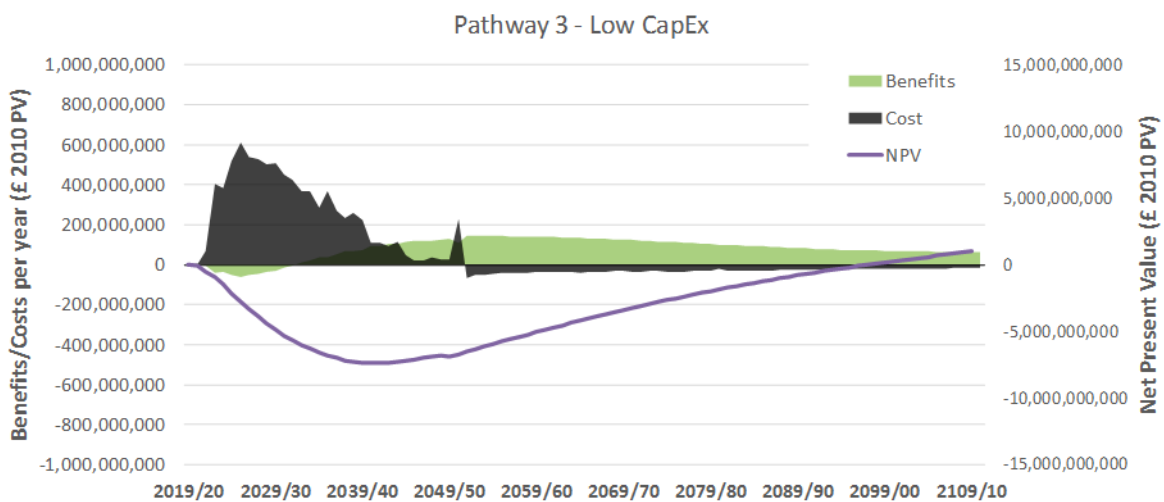

Figure 16: Benefits (green) and costs (black) per year with cumulative NPV trend (purple).

6.5.11 As can be seen over ninety years, the profile of costs is front loaded, representing the initial capital outlay. There is a lag in the benefits occurring, but they build as infrastructure is delivered and capital costs diminish. Eventually, costs become negative, when the capital investment is finished, and the operational cost savings and revenue generated outweigh any ongoing renewals required.

6.5.12 The NPV traces the differential over time, accumulating benefits as they grow, becoming positive in this case around eighty years from the beginning of the appraisal. The graph highlights the importance of understanding the sensitivities around the length of the appraisal, with the assumed 90-year appraisal period meaning that the NPV for this option rises to just under £1bn (2010 PV). The NPV in this instance reaches -£7bn (2010 PV) by 2040 further highlighting the significance of the investment and the time required for it to “pay-back” the investment.

6.5.13 Comparing this against Pathway 5, in Figure 17 below, a similar profile of upfront costs, albeit over a longer period of time, and the steady rise in benefits after the initial lag is visible, showing an improved affordability profile. Equally the overall value for money improves with the NPV becoming positive around seventy years into the appraisal and a total NPV of £1.6 bn (2010 PV). The NPV over time reaches as low as -£5bn (2010 PV) in this pathway.

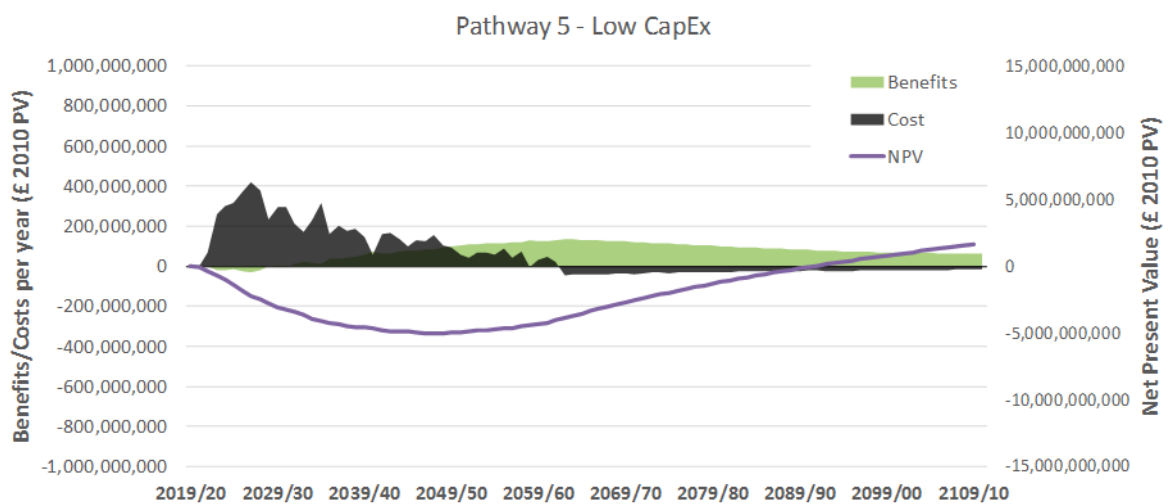

Figure 17: Benefits (green) and costs (black) per year with cumulative NPV trend (purple).

6.5.14 Comparing these against Pathway 1, in Figure 18 overleaf, again a similar profile of upfront costs is seen although this time over an even longer period of time,

this also results in a slower realisation of benefits with the NPV being diminished to only £300m (2010 PV).

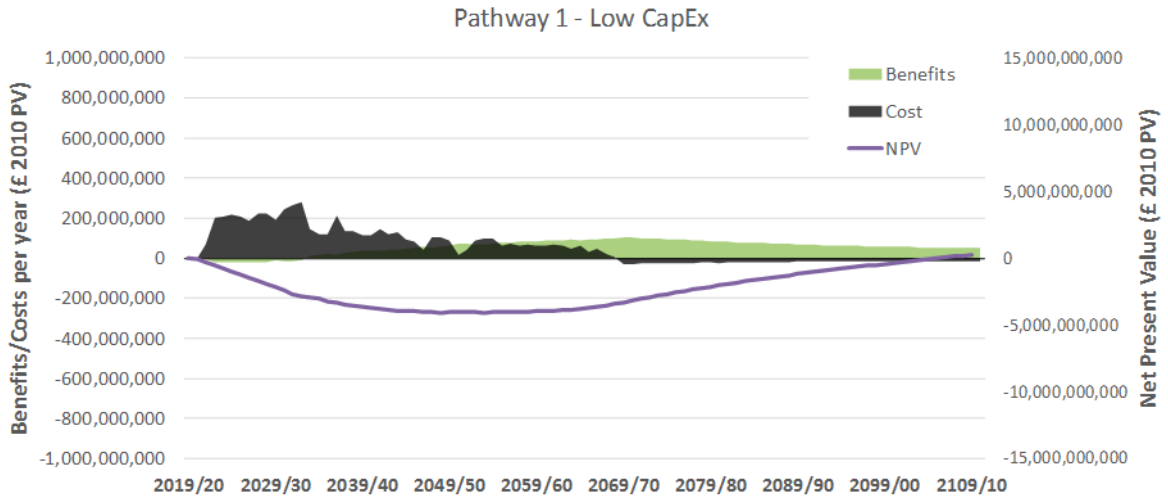

Figure 18: Benefits (green) and costs (black) per year with cumulative NPV trend (purple).

6.5.15 Finally, in Figure 19 the fast paced and high ambition pathway 4 is shown to have a significant upfront cost in comparison to pathways 2,3 and 5. The consequence is that the NPV over time reaches as low as -£10bn (2010 PV) around 2035, and whilst benefits accumulate earlier, they only pay back fast enough to achieve an overall NPV of £400m (2010 PV).

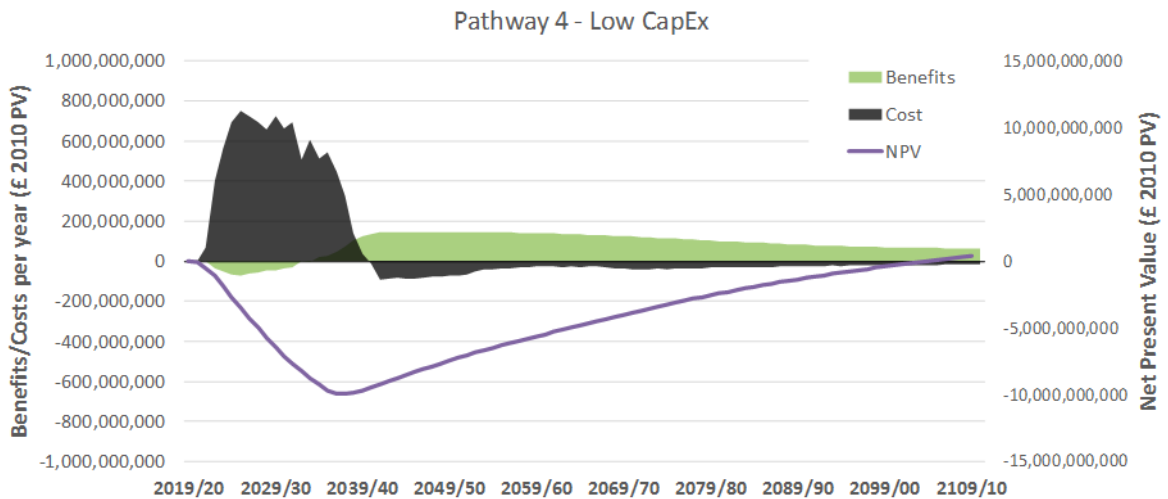

Figure 19: Benefits (green) and costs (black) per year with cumulative NPV trend (purple).

6.5.16 This ultimately shows that the pathways which provided higher emissions reductions delivered over a longer period provide a good balance of value for money and affordability.

6.6 ANALYSIS OF OUTPUTS

BREAKDOWN OF BENEFITS

6.6.1 Figure 20 summarises the average composition of economic benefit across the decarbonisation pathways. This section outlines the key considerations associated with each of these in greater detail.

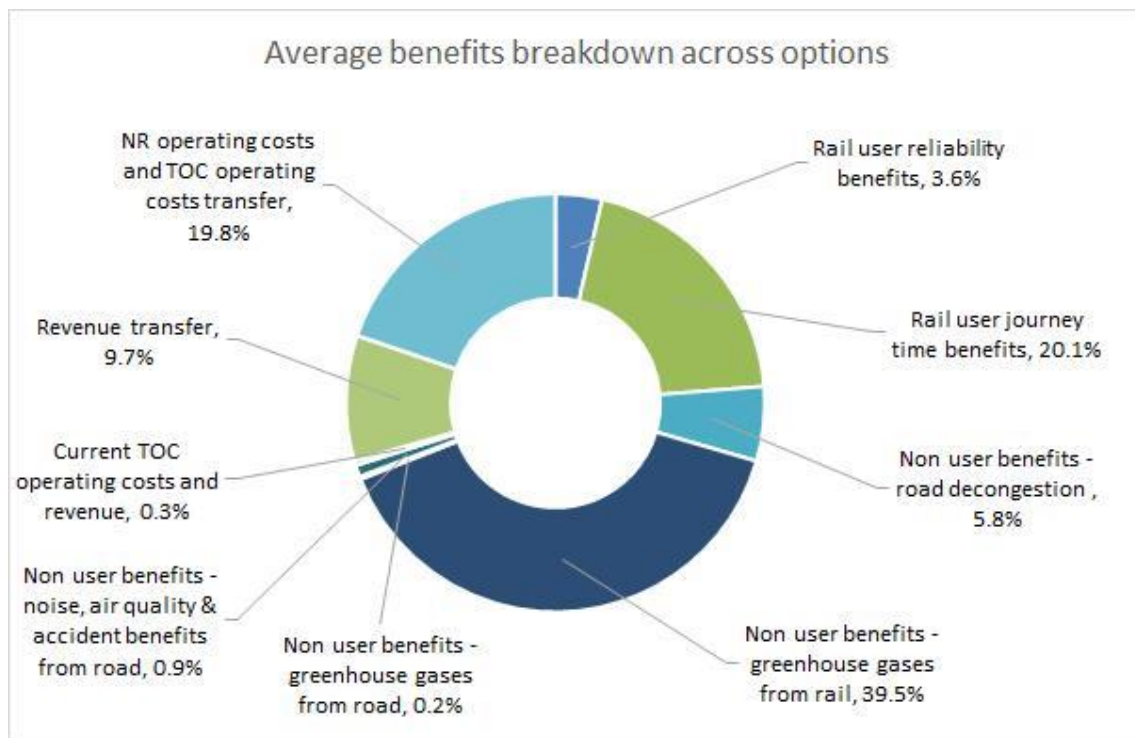

Figure 20: Average benefits breakdown across the decarbonisation pathways

NON-USER BENEFITS – EMISSIONS, NOISE AND ACCIDENTS

6.6.2 Of the quantified benefits, approximately half are classed as ‘non-user’ benefits. This includes the reduction in CO_{2e} from removal of diesel trains, as well as the benefits of reducing the number of cars on the road. This is unsurprising given the primary objective of the programme and the interventions have been focussed exclusively on meeting this objective.

6.6.3 The estimated breakdown of benefit associated with decarbonisation of passenger and freight traction suggests that approximately 20% of overall CO_{2e} benefits come from decarbonising freight traction, with the remainder being derived from decarbonising passenger traction.

JOURNEY TIME IMPROVEMENT

6.6.4 Rail user journey time benefits alone account for around one-fifth of overall economic benefit. Journey time benefits are accrued primarily through the enhanced acceleration and deceleration of trains powered by non-diesel traction. Capacity analysis work undertaken as part of TDNS has identified that there is a higher proportional journey time saving for shorter journeys than for longer journeys.

ROAD DECONGESTION

6.6.5 Road decongestion provides a further 5% of overall economic benefit. Estimates of road decongestion benefit are based on long-standing evidence that improving the passenger service – either through direct journey time improvements or improvements to train service performance – will increase the demand for rail travel. Improving train services relative to the offer of other modes is assumed to have the effect of improving rail’s market share at the expense of other modes.

6.6.6 In most rail appraisals, road decongestion effects tend to be the primary source of non-user benefit (as opposed to the decarbonisation of traction). However, with the principal focus on traction decarbonisation rather than the broader decarbonisation of travel, the quantified results show that non-user benefits are primarily from carbon reduction achieved by the removal of diesel services.

6.6.7 As outlined in the strategic case there is a strong case for using rail to support in the decarbonisation of the wider surface transport sector, especially for freight. The DfT’s Transport Decarbonisation Plan will explore in greater detail the modal shift opportunities which exist.

IMPROVED RELIABILITY

6.6.8 All three traction types are significantly more reliable than diesel as a result of greater simplicity and a reduction in the number of moving parts. 4% of overall economic benefit comes from improved reliability of train services as a result of the change of traction type away from diesel. How this is calculated is explained in greater detail below.

6.6.9 Reducing train failures has an impact on rail users by reducing so-called “primary” delays (i.e. a train fails and the passengers on that train experience delay) but also by reducing so-called “reactionary” or knock-on delays (i.e. passengers on the trains delayed by the failed train also experience delay). Reactionary delay comprises circa 75% of overall delay, so even a marginal

improvement in train reliability is likely to drive broadly three times the value of this direct impact in terms of improved performance at a network level.

- 6.6.10 The change in reliability with regard to AC electric rolling stock is well understood as it is an established technology on the mainline railway. Reliability of the other technology options – battery and hydrogen – is less well established but with evidence emerging as these trains enter operational service both in the UK and wider Europe this will become clearer.
- 6.6.11 For electric traction which relies on fixed infrastructure to operate reliably considerations of the infrastructure also must be made. For these trains, analysis of train operating company delays by delay category per 1000 unit kms up to March 2020 suggests circa forty percent of reliability improvements from train delays are offset by an increase in electrical infrastructure related delays. As a result, assumed reliability benefits for electric traction are around 60% of the theoretical performance improvement total.
- 6.6.12 The TDNS analysis identifies that a rolling stock reliability increase of between 14%-23% relative to the do-minimum is possible for passenger rolling stock. Alongside this freight rolling stock reliability improvements of 100%-150% are assumed. The assumption that only 60% of these benefits are then captured for rolling stock using electrical infrastructure (and 100% for other rolling stock) is subsequently applied to calculate the reliability benefits passed onto passengers.

OPERATIONAL COST SAVINGS AND REVENUE

- 6.6.13 The focus of the appraisal is on the economic return in the form of economic benefit and operating cost reduction that Government achieves by way of decarbonising traction. Increasing rail revenues will – all other things remaining equal – reduce the cost to government of funding the railway. On average 30% of the quantified impacts stem from increased revenue and the corresponding reduction in in the cost to government.
- 6.6.14 Across all the pathways, the capital investment costs are partly offset by revenue increases and operational cost savings with around 32% of initial capital expenditure recouped over the 90-year appraisal period as a result of reduced operating expenditure and increased passenger revenue.

DISRUPTION DISBENEFIT

- 6.6.15 Electrification schemes tend to be disruptive to passengers and freight operators during construction. As a result of this disruption, train operators are compensated for the financial loss to their business, passengers are adversely

affected, and this reduces the economic benefit of the programme overall as this must be recorded as a disruption “dis-benefit”.

6.6.16 Without doing detailed development work it is not possible to accurately quantify the quantum of this. However, an assumption for the Schedule 4 cost as a proportion of overall capital cost has been used within TDNS. On the basis of this assumption, benefits lost as a result of disruption during construction equates to an overall reduction of economic benefit of circa 10% reduction of the economic benefit outlined in Figure 20 and discussed above.

BREAKDOWN OF COSTS

6.6.17 There is a fundamental economic difference between the three technologies with a clear trade-off between capital and operational cost. The optimum technology from a cost-per-vehicle-km perspective is dependent on the level of network activity for a given area or service.

6.6.18 Electrification involves relatively high one-off or long-lived asset costs but very low marginal costs for the train services which use it. Conversely, battery and hydrogen traction involve a relatively lower capital cost but higher on-going operational costs.

6.6.19 The balance between capital and operational expenditure has been considered with initial findings on the cost functions for electric, battery and hydrogen shown in Figure 21 overleaf.

6.6.20 The full Programme Business Case in October will explore these cost functions in more detail, outline the major uncertainties which will affect them and how these can be managed as a result of wider aspects contained within the commercial, financial and management cases.

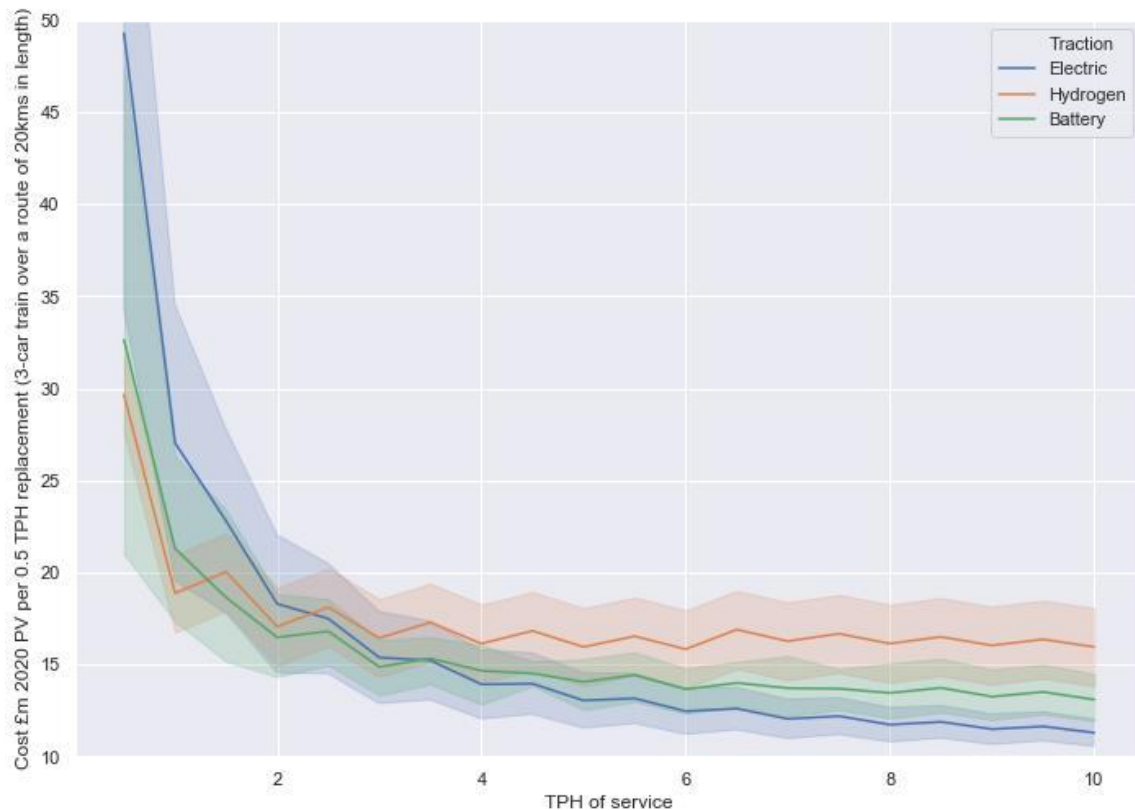

Figure 21: Whole Life-Cycle cost function analysis for electric, hydrogen and battery traction based on intensity of service.

6.6.21 This initial graph shows that the technology selection based on whole life cost alone is unclear between the three traction technologies where there is a relatively low service provision. However, beyond the point where four or more three-car DMU's per hour operate, AC electrification begins to provide the lowest whole-life cost for traction decarbonisation. Note that this is based on the high-end capital cost assumptions.

SCHEME BASED CONSIDERATIONS

6.6.22 The considerations made within TDNS are at a macro scale and given the limitations and uncertainty associated with this analysis cannot factor in specific benefits which may be realised at scheme level. Individual schemes looking at traction changes away from diesel will typically consider other areas such as service frequency changes.

6.6.23 Equally for electrification this may be delivered in conjunction with other works such as alterations to track alignments, signalling or station alterations as part of a wider line of route upgrade. Each of these aspects will introduce costs and

benefits of their own but as this would be scheme-specific they are out of the scope of TDNS and are subsequently not considered.

6.6.24 This analysis uses high level “top-down” cost and benefits assumptions in order to provide an indication of the magnitudes of cost and benefit and their subsequent relationship. Careful consideration should be taken by Network Rail Regional teams and others when developing discrete projects as a result of TDNS that scheme economic analysis considers all factors (both costs and benefits) through “bottom-up” development work. Where projects and programmes undertake additional scope, beyond that considered as part of this appraisal, costs will increase but equally greater levels of benefit should also be realised.

6.7 SENSITIVITIES

CHANGES TECHNOLOGY

- 6.7.1 At present the TDNS economic modelling and subsequent outputs are predicated on a number of underlying assumptions. Most notably the recommendations made throughout TDNS for battery and hydrogen technology are based on the capabilities of these technologies at a fixed point in time with some small increases in baseline capability.
- 6.7.2 Equally, assumptions around changes in diesel engine efficiency have not been included in either the do-minimum or do-something pathways as there is no credible evidence to provide an assumption. The cost effectiveness of improving diesel engine efficiency is likely to be heavily influenced by the timescales in which the end state recommendations made in section 5.8 are delivered.
- 6.7.3 In the full PBC the impact of an assumed increase in power output for hydrogen and battery powered rolling stock will be assessed with a view to establishing potential ranges of change.
- 6.7.4 As TDNS is planned to be refreshed on a cyclical basis (this is outlined further within the Management Case) it is envisaged that changes to the fundamental characteristics of the technologies, as well as changes to potential costs and benefits, will be picked up as part of this.

THE ECONOMIC VALUE OF CARBON

- 6.7.5 As outlined in section 6.6, the key driver of benefit is emissions reduction and as a result the benefit of this across the decarbonisation pathways is sensitive to changes in the value of carbon removal that is applied.

- 6.7.6 At present, the value of carbon is derived from the Department of Business, Energy and Industrial Strategy (BEIS) estimates¹⁴². The UK Government adopts a target-consistent approach, based on estimates of the abatement costs that will need to be incurred in order to meet specific emissions reduction targets rather than on the cost of climate change-related damage.
- 6.7.7 Whilst the importance of uncertainty in this area is recognised, consideration of this uncertainty will affect all elements of decarbonisation business cases across all sectors of the economy.
- 6.7.8 Nonetheless, in the full TDNS PBC, the impact of a range of carbon values on the value for money of decarbonisation will be assessed.

PASSENGER JOURNEY AND REVENUE GROWTH

- 6.7.9 The TDNS analysis started before the Covid-19 health crisis and the associated restrictions on travel that were subsequently introduced. Broadly 50% of modelled benefits are dependent to some degree on the volume of passenger demand. Clearly the short-term collapse in passenger demand would – if sustained – have an impact on both the value for money and the cost-effectiveness of the programme.
- 6.7.10 The impacts of Covid-19 are not included as part of this analysis, this will require careful ongoing consideration as these impacts become clearer. This is outlined further in section 6.8.

CAPITAL COSTS

- 6.7.11 Some programmes within the CP5 electrification portfolio demonstrated significant cost escalation during their lifecycle. The reasons for the cost escalation have been identified via a number of reviews¹⁴³. Work undertaken by the Rail Industry Association (RIA) and Network Rail (see case study 5) has demonstrated the opportunities for efficient delivery of electrification, and it is envisaged that embedding the lessons learned combined with a long-term delivery programme will enable efficiencies to be realised.
- 6.7.12 The full TDNS PBC will contain high and low cost sensitivities. The high cost sensitivity will apply a greater percentage uplift to the upper bound of the central case cost limit and the low-cost sensitivity will apply a lower level of cost from the lower bound of the central case. Given the level of economic, technological, and social uncertainty that infrastructure schemes face

¹⁴² Department for Business, Energy and Industrial Strategy, Carbon Valuation, <https://www.gov.uk/government/collections/carbon-valuation--2>.

¹⁴³ National Audit Office, 2015, Planning and delivery of the 2014-2019 rail investment programme, p.4.

compounded with the foreseeable risks that have historically materialised, these sensitivities will present a wider range of electrification costs. This will capture the impacts of the potential risks, opportunities and factors determining the successful delivery of efficient and affordable decarbonisation at an early stage.

6.8 ECONOMIC CASE LIMITATIONS

6.8.1 As the analytical assessment of the economic case has been taken at a strategic level and to ensure proportionality, a number of simplifying assumptions have been made that underpin the limitations and caveats of the analysis. These have been stated in the relevant sections of the document. They are summarised below.

- To achieve each pathway target and net zero there is an assumption made that the demand on, and the capability of, the supply chain to deliver electrification is stable and continuous. This makes the assessment insensitive to factors that have historically impacted the costs of electrification, for example the stop/start profile in previous years. Embedding the lessons learned from previous programmes is critical to efficient delivery.
- For representative purposes a national assumption for passenger time reduction has been taken in line with Table 12.
- An assumption of 1.04% passenger growth per annum - this assumes a constant linear projection of rail passenger growth and, given the recency of the crisis, does not consider the impacts of Covid-19. Due to the uncertainty in rail passenger growth, the transport user benefits presented in the assessment have a higher level of uncertainty and may be higher or lower than those shown, dependent on passenger growth. This uncertainty is likely to be unsymmetrical with negative impacts more likely than positive impacts. For the TDNS PBC, the economic assessment will be updated to include Covid-19 related sensitivities.
- Alongside the uncertainty in Covid-19 related effects, the recent March 2020 economic forecasts from the Office for Budget Responsibility (OBR) project significantly lower productivity and income growth compared to previous forecasts. This latest forecast does not feature in the 1.04% per annum passenger growth figure used in the analysis. These OBR forecasts will be closely monitored going forward and it is recommended that enhancement schemes which seek to decarbonise the rail network consider such forecasts.

- No change in timetabling or fleet management opportunities have been assumed due to the introduction of electrification on services. This potentially has the capability to unlock further transport user benefits as journey times can be further optimised.
- Air quality and noise benefits have not been assessed or included – see section 5.5. Line of route air quality and noise benefits are not currently covered within the separate workstreams identified and, whilst it is difficult to isolate these benefits, these will be considered to some level within the TDNS Programme Business Case.
- An assessment of crowding impacts has not been included as outlined in section 6.4. If accounted for, the level of benefits/dis-benefits incurred would depend on the relative amount of new passenger demand that electrification would induce due to mode shift.
- The costs of alternative fuels have been assumed constant and the analysis is insensitive to cost fluctuations. The technologies are premature in their development compared to electrification and so are subject to greater cost uncertainty. This limits the assessment in fully accounting for cost implications that could arise as such technologies mature.
- Costs and benefits of wider route upgrades (e.g. signalling upgrade work, capacity or capability improvements) that electrification schemes are usually a part of have not been included in the economic assessment as they have been considered out of scope due to the assumption for analytical purposes that the non-carbon outputs of the network will be held constant.
- Continuous electrification infrastructure has been assumed (as opposed to discontinuous electrification and the whole system costs and benefits associated with this will need to be identified through local programme development).
- The timetable assumed for the do-minimum is set out in section 6.3. This is based on today's passenger and freight timetables with an assumption as to the level of service change associated with HS2 delivery. This assumption was based on timetable data provided from the Department for Transport.

6.9 ECONOMIC CASE: CONCLUSIONS

The capital cost for infrastructure associated with the modelled pathways ranges between £18bn and £26bn (in 2020 prices). The total capital expenditure estimated for each of the modelled pathways represents multiples of between circa. 1.7 to 2.4 times the total CP6 enhancements budget¹⁴⁴ and would be spread over at least five control periods (i.e. five year funding periods). When spread out over the length of delivery for each pathway, the average capital cost expenditure per control period amounts to between 17% and 58% of the equivalent CP6 enhancements budget.

The financial and affordability implications of this will be considered in the full PBC, but for the purposes of this economic case, the capital cost is important because it drives how efficient, from an NPV and cost-effectiveness viewpoint, each pathway is.

Additional capital costs from line-of-route upgrades would be expected alongside these strictly decarbonisation related costs, as individual projects to deliver decarbonisation will likely be designed to deliver additional improvements. Equally there will be additional costs for rolling stock for both passenger and freight operations.

The higher real-terms capital cost investment in Pathways 3, 4 and 5, in comparison to Pathways 1 and 2 leads to higher overall Net Present Value. However, the rate at which that investment is made has a significant influence on the net present value. This is shown overleaf in Figure 22, which shows the discounted capital cost expenditure of each pathway compared with the resulting Net Present Value. The graph demonstrates that higher emissions reduction ambition delivered over a longer investment period leads to improved value for money over less ambitious or faster rates of investment.

¹⁴⁴ see <https://www.networkrail.co.uk/wp-content/uploads/2020/03/cp6-delivery-plan-update.pdf>.

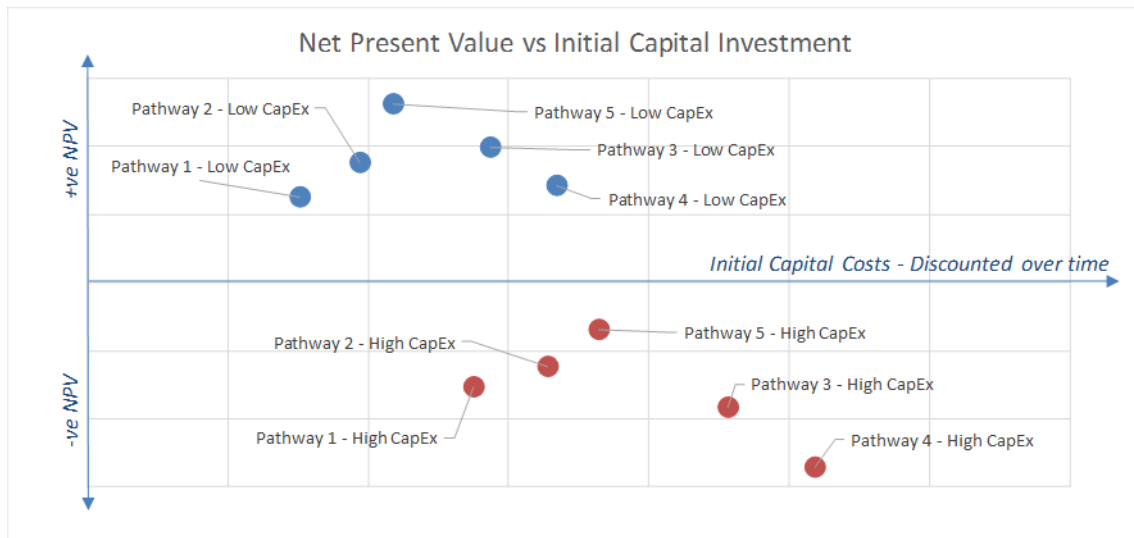

Figure 22: Comparison of capital cost and NPV

Out of the total 40% of direct emissions reduction benefits in the appraisal results, the reduction in diesel freight locomotives on the network contributes approximately 20% of this. In addition to this, the replacement of diesel locomotives with newer electric locomotives is estimated to improve rolling stock reliability, such that knock on delays to passengers are reduced. This contributes circa 25% out of the total 4% journey reliability benefits in this appraisal. Both passenger and freight services bring value to the economic case, and both are important to offsetting the capital investment costs required for decarbonisation.

The economic analysis shows that rail decarbonisation can generate a return in value within a ninety-year period from 2020. This is subject to the speed of capital investment, scope of decarbonisation, and how cost estimates for decarbonisation mature over time.

There are a number of uncertainties associated with this analysis which have been identified throughout the case. The TDNS PBC will explore some of these uncertainties in greater detail.

Further development of rail decarbonisation is therefore likely to be a worthwhile objective on its own terms, and comparison of this analysis with other modes will help to inform where the greatest decarbonisation opportunities lie within the wider transport sector.

Finally, although broadening the economic case for rail-focussed decarbonisation beyond traction will mean additional costs, it will also drive a more diverse range of benefits. Having a more broadly-based set of objectives post-TDNS will therefore make uncertainty more manageable and will be likely to make TDNS-focussed project business cases more robust.

7. COMMERCIAL CASE

7.1 INTRODUCTION

Whilst the commercial case for traction decarbonisation will not be considered in full until the TDNS Programme Business Case is issued in October 2020, this section has been populated in order to outline the emerging thinking and planned work to be undertaken as part of the PBC.

This case, along with the financial and management cases, analyses the feasibility of delivering TDNS. The commercial case outlines the current railway market in Britain and its possible evolution as a result of the Williams Rail Review. It also outlines the interactions between the proposals made so far in this document and the existing and future possible commercial models of railway operations and capital delivery.

There are currently no commercial barriers in delivering the decarbonisation projects proposed by TDNS, but capability and capacity of Network Rail and supply chain resources will need to be considered further now the extent of intervention required is clearer. The existing commercial arrangements between the National Governments, Network Rail, and individual TOCs and FOCs may be altered by the implementation of changes following the Williams Rail Review. The proposals made within TDNS are suitable for different models of industry structures so that rail services are placed to serve an increasing demand, and with the potential to increase modal share. If the Williams Rail Review is published in advance of the TDNS Programme Business Case in October 2020, emerging changes in the industry structure can be explored. If this is not the case, a further update to the commercial case will need to be provided beyond October 2020 once the review has been made available and its impacts understood.

The capabilities of a constrained and specialised supply chain identify a realistic upper limit of decarbonisation that could be delivered in a reference period and these begin to be outlined in this case. Without doubt, there will be a significant upscaling required to transition from the present situation, which is dependent on a boom-and-bust cycle of investment, to a sustained supply of materials and workforce. However, a sustainable programme of decarbonisation is required if the 2050 targets are to be met.

7.2 NETWORK RAIL CAPABILITY

- 7.2.1 There is currently an imbalance in the geographical split of electrified lines in Britain, with the South East and routes to and from London, along with routes between Edinburgh and Glasgow, consisting mostly of electrified infrastructure. Many of the regional lines proposed for electrification lie away from these areas.
- 7.2.2 It is envisaged that schemes recommended as part of the TDNS will proceed through the Rail Network Enhancements Pipeline (RNEP) process. To support the progression through the RNEP of the required volume of electrification per year, each region will need to assess the capabilities of its own staff to support project development and delivery. This is of particular relevance for the North West and Central and Eastern regions, which have significant volumes of electrification required.

7.3 SUPPLY CHAIN CAPABILITY

INFRASTRUCTURE

- 7.3.1 The historic analysis in the Electrification Cost Challenge report published by RIA in 2019, shows that for overhead line electrification a goal of 450 STK of delivery per year is within the capabilities of the supply chain, subject to steadily building up activity from the present low level. The historic volumes are shown in Figure 23 below.

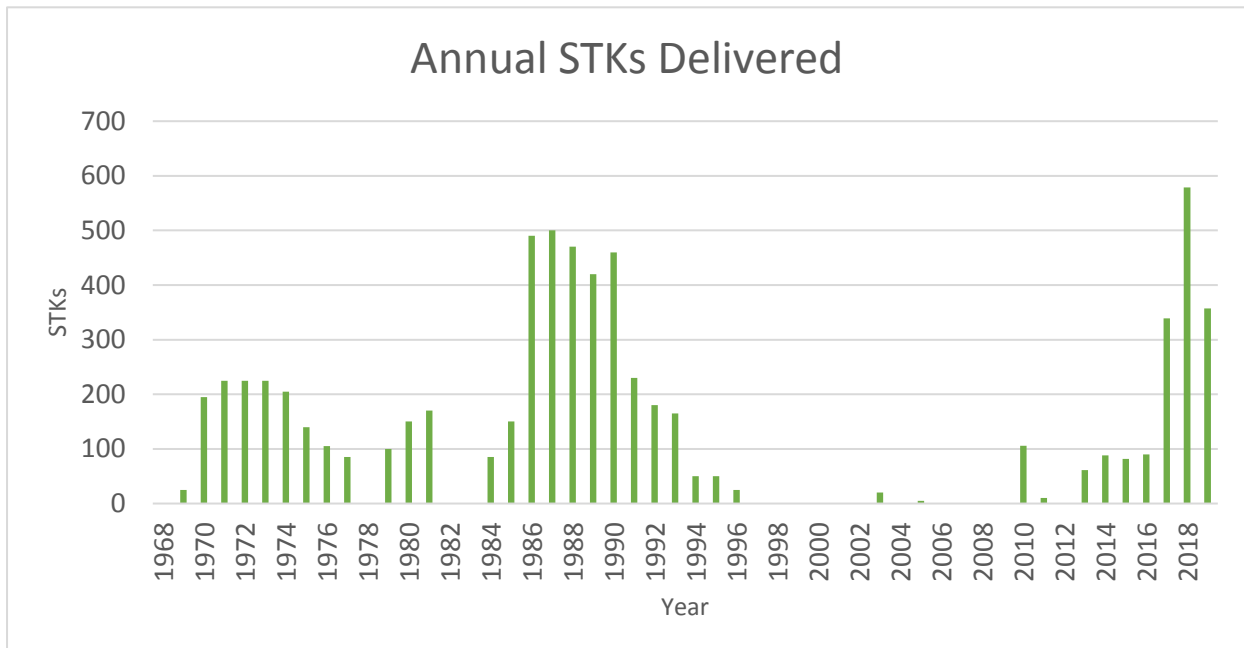

Figure 23: Historic STK delivery volumes 1968-2019

- 7.3.2 These numbers could be reached by employing delivery teams consistently in action, by the means of a continual programme of electrification, with each team delivering 75 to 100 STK/year.
- 7.3.3 It is recognised that electrification requires a highly specialised workforce in order to hit the performance goal of around 450 STK a year. As extensively discussed in the Electrification Cost Challenge report published by RIA in 2019, establishing a long-term programme of electrification would ensure that training the needed workforce would be cost-effective as these jobs would be retained.
- 7.3.4 With this analysis having been undertaken in advance of the TDNS recommendations outlined in this document, the industry capability is considered indicative. TDNS will be working closely with the supply chain through RIA to undertake a market sounding exercise as part of the development of the TDNS PBC.
- 7.3.5 Table 14 outlines the volumes of electrification required as part of TDNS from the economic modelling runs used as part of this analysis. As can be seen, if a 100% reduction by 2050 is required, greater annual volumes will be needed than those identified by the previous RIA work. The findings of the proposed market sounding exercise and a comprehensive summary of the supply chain's capability will be outlined in the Programme Business Case.
- 7.3.6 The decarbonisation construction projects would be primary drivers of the green economy, helping both to create jobs involved in sustainability and stimulating demand through a highly specialised and advanced supply chain. This would not be limited to the supply of machinery and plant but would also maintain and create skills among the engineering firms involved with these projects. For the companies supplying the design and engineering services, TDNS projects would add significant material to a project portfolio, potentially helping them compete on the international market.

Traction Decarbonisation Pathway	Average Annual STKs over programme	Maximum STKs in any one year
Pathway 1 (-80%)	259	377
Pathway 2 (-95%)	303	447
Pathway 3 (Net-Zero by 2050)	355	691
Pathway 4 (Net-Zero by 2040)	658	922
Pathway 5 (Net-Zero by 2061)	303	447

Table 14: Indicative electrification infrastructure volumes from economic pathways

- 7.3.7 As a point of context, the volumes of delivery seen during major electrification programmes such as East Coast in the late 1980s and more recently the CP5 electrification schemes saw an annual average delivery rate of between 300 to 450 STKs as shown above in Figure 23.
- 7.3.8 Where electrification work is undertaken there are times when signalling immunisation work may be required. This will require utilisation of signalling resources which are a critical resource within their own right. Ensuring the signalling supply chain is capable of delivering these associated works will also be an area requiring consideration.
- 7.3.9 Whilst it appears in principle to be feasible to deliver the volumes of electrification required to achieve zero emissions by 2050, consideration will need to be given around the efficiency of delivery and the disruption impact on the rail network. As outlined in the economic case, there is a clear tipping point between slower and faster delivery which subsequently impacts the value for money of the programme as a whole. In order to ensure this efficient delivery and minimise disruption to the network, it may be necessary to deploy interim solutions with the electrification programme extending beyond 2050. This will be explored in greater detail in the TDNS Programme Business Case.

ROLLING STOCK

- 7.3.10 The number of new vehicles committed for delivery in CP5 and in the early years of CP6 is above 7,000, at a capital cost of more than £13 billion.¹⁴⁵ These numbers are at record levels, especially if compared with the total fleet of around 14,000 vehicles. As many older vehicles will be retired, the average age of the national fleet will fall to 15 years by 2021. It looks therefore within the capabilities of the manufacturing industry to supply new and modified vehicles as required by the TDNS projects.
- 7.3.11 The vision for TDNS is to have railway services completely operated by non-diesel rolling stock. Before this target is met, several discrete steps are needed where diesel trains will continue operating. One of the key considerations for the programme of decarbonisation, from an operational point of view, is to prioritise the replacement of vehicles with the shortest remaining asset life.
- 7.3.12 The TDNS delivery programme will be structured so that, by aligning to rolling stock renewals, a continuity of orders can be ensured, and order numbers can be maximised. This will be presented as part of the TDNS Programme Business Case in October 2020.

¹⁴⁵ RDG, 2018, Long term passenger rolling stock strategy for the rail industry, p.1.

7.3.13 As freight services collectively use a more limited number of vehicles compared with passenger services, and the lifespan of freight locomotives is longer than a typical passenger train, the market for freight rolling stock is smaller, and the ability to deliver freight locomotives in a cost-effective manner is more affected by order sizes.

7.4 DELIVERY STRUCTURES AND PROCUREMENT

CIVIL AND OLE WORKS

- 7.4.1 It is expected that the delivery of the infrastructure necessary to deliver TDNS projects will follow the usual NR procurement processes.
- 7.4.2 Depending on the size and scale of discrete projects, different contracting methodologies will be required. When determining the contracting strategies, consideration will be given to other enhancements not necessarily associated with electrification or a rolling stock change, such as track alterations or deployment of digital signalling. Economies of scale may be achieved by combining enhancements together as part of a line of route upgrade.
- 7.4.3 Whilst TDNS does not consider these aspects and only outlines costs and approaches for delivering infrastructure and rolling stock associated with achieving traction decarbonisation, considerations of synergy with other enhancements should be made during the development of discrete projects and programmes to deliver the recommendations set out as part of TDNS.

ROLLING STOCK AND ASSET RENEWAL CONSIDERATIONS

- 7.4.4 The ability to purchase and lease more non-diesel stock would lead to savings directly related to the lower capital costs of procuring electric units.
- 7.4.5 Under this model, operators could be able to procure the rolling stock under the usual leasing options.
- 7.4.6 As FOCs operate competitively without direct public funding, under current arrangements, they will bear the costs of replacing diesel locomotives with electric ones. As a consequence of a long operational life of up to thirty years for freight locomotives, there is a delay between the introduction of new technologies and the renewal of rolling stock. This would be similar for the newest passenger rolling stock also.
- 7.4.7 This puts the rail freight sector at a disadvantage compared with the road freight sector, where the choice of technology today will not impact significantly

operations for more than one asset lifecycle, of around ten years. At the same time, TDNS will provide certainties to the rail freight sector to support investment in rolling stock of a specified traction type.

7.4.8 As outlined earlier, decisions regarding the purchase of new electric locomotives will be required in the short-term, but the technology choice will affect operations for a long period and require commitments from funders. As further electrification of the network is completed, FOCs are likely to increase their numbers of electrically hauled locomotives.

7.4.9 Given the size and scale of the recommendations made as part of this work it is likely there will be significant consideration required by the industry as to the most appropriate way to procure and operate electric locomotives. This may include the need for grants or support as the transition occurs. These aspects will be outlined in further detail within the TDNS Programme Business Case.

7.5 COMMERCIAL CASE: CONCLUSIONS

Converting the unelectrified railway lines in Britain to non-diesel operations is evidently not a small task. However, the projects that TDNS comprises and the proposal of delivering them through a programme of decarbonisation are both commercially feasible considering the current capabilities of the supply chain. Considerations around electrification and signalling resources as well as the level of network disruption which can be accommodated in delivering the required infrastructure will be considered as part of the Programme Business Case.

This case has assessed that the infrastructure required by the TDNS electrification projects can be delivered given the existing market capabilities, if a programme of development and delivery is established to ensure workforce and supply chain are kept in active operation and the peculiar skills necessary to deliver OLE construction works are maintained. The potential delivery volumes for electrification will be defined as part of a market sounding exercise to be undertaken as part of the TDNS Programme Business Case.

BMUs and HMUs, while not in need of as extensive infrastructure and therefore design and construction works, will require provision of new depot locations and modifications to existing depots to conduct refuelling and maintenance activities, as well as charging points at stations for on-the-go battery recharging. These however are not as disruptive to passenger and freight operations as electrification. Introducing these changes is not expected to be disruptive to the supply chain, given the limited number of areas where such works are expected to take place concurrently. Introducing new technologies is expected to necessitate a learning curve to conduct maintenance activities as efficiently as for rolling stock of established traction types.

Several benefits arising from the lower overall capital and operating costs of non-diesel rolling stock will mean either increased farebox revenue or lower operating expenditure for the infrastructure owner and the service operators.

This case has begun to outline the emerging thinking being undertaken as part of TDNS. A comprehensive set of findings will be presented as part of the TDNS Programme Business Case in October 2020.

8. FINANCIAL CASE

8.1 FINANCIAL CASE: SUMMARY

This section assesses the affordability of delivering TDNS considering the initial capital expenditure needed in order to convert unelectrified lines into a decarbonised traction type and the availability of funding strategies.

TDNS project spending will have to be considered within the overall budget for the Control Periods where projects are forecasted to be delivered.

Despite TDNS proposing an ambitious programme of decarbonisation, the level of infrastructure expenditure identified over a thirty-year time period is consistent with government funded rail infrastructure investment over the last decade and is therefore assumed to be affordable. It is expected that the initial capital expenditure for infrastructure will be funded by Governments, subject to the usual demonstration of efficient and effective development, procurement and delivery.

The return on investment will be generated by operating cost savings, increased revenue, either direct or through corporate tax, and lower GHG emissions. This return will be independent from the commercial agreement in place with the actual operators of a passenger service and will be reflected in either revenue or subsidies. The Economic Case has outlined that there is potential to achieve benefits up to the value of £1.5bn more than capital costs required.

8.2 SPEND PROFILE

CAPITAL COSTS

8.2.1 In order to allocate infrastructure capital costs, the unelectrified rail network was defined using one-hundred and fifty-one segments.

8.2.2 The development of individual TDNS projects will result in detailed construction scheduling and will likely see amalgamation of some of these segments into specific geographic scopes. For the purpose of TDNS all the appraised segments used in the analysis have been assigned a cost rate for a single-track kilometre of electrification based on their complexity. Complexity has been assessed using the range of criteria outlined below:

- length of segment;
- complexity of civil engineering (i.e. considering the number and nature of bridges and tunnels on the segment);

- economic cost of disrupting traffic on the segment; and
- likely project duration.

8.2.3 Electrification capital costs at this stage have been estimated using a wide total cost bracket spanning from £1m/STK to £2.5m/STK. The lower end is a generally accepted figure for OLE construction where civil works are negligible, as per the RIA Electrification Cost Challenge and Efficient Electrification Executive Summary reports. A summary of the Efficient Electrification Executive Summary is provided in Case Study 5. The upper limit has been empirically derived from electrification projects of greater civil engineering complexity and has been validated by the Network Rail regional teams.

8.2.4 Overall there were one-hundred and seven different segments identified for electrification as part of the TDNS analysis outlined in section 5.8 equating to 13,200 single track kilometres. The cost allocation for these segments and their associated single-track kilometres are summarised in Figure 24 below.

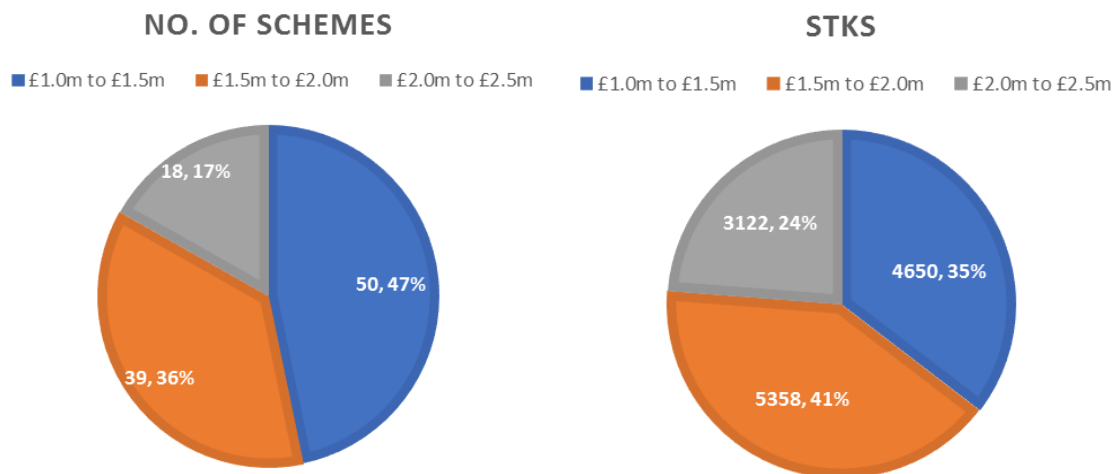

Figure 24 Number and percentage of electrification schemes (left) and STKs (right) allocated to each complexity group

Case Study 5 – Enabling Efficient Electrification

Network Rail Technical Authority in response to the challenges outlined by the Rail Industry Decarbonisation Taskforce undertook an appraisal of electrification costs in collaboration with Scotland's Railway Region to determine the most appropriate efficient cost allocation for electrification projects. This culminated with the Efficient Electrification Executive Summary which outlines the most appropriate cost allocation and considerations for future electrification schemes.

The paper identified that costs of electrification projects vary significantly as a result of variations in: track access arrangements; geography; gauge of existing structures; topography; ground conditions; traction power capacity and programme duration. The vast majority of electrification project cost is not on electrification items, with direct electrification materials comprising less than 5% of overall project cost.

As well as indicating a range of STK outputs of between £1.25m and £2.9m per STK for historic projects in Scotland the paper outlines a number of potential opportunity areas with an order of magnitude saving. These include:

- Clearances to overline structures (potential saving of 0-8%).
- Clearances to platforms (potential saving of 0.2%).
- Access Improvements (potential saving of 0-11%).
- OLE Technology (potential saving of 0-1%).
- Substation IPC (potential saving of 0-1%).
- Consecutive delivery (rolling programme) (potential saving of 0-2%).

Subsequent work undertaken by Network Rail's Technical Authority and the Great Western Electrification Programme has shown the potential to minimise electrical clearances in complex areas. This was achieved at Cardiff Intersection Bridge, where reduced electrical clearances were agreed to support electrification of a complex area.

EU regulations outline the need to provide up to 1.8m high bridge parapets for bridges over electrified railway. Work being led by Network Rail's Technical Authority and Scotland's Railway is challenging the need for this based on the disproportionate costs this brings. Analysis work following the EGIP programme has identified that providing parapet heights of 1.8m increased the cost of bridge work by around £135k per structure compared to providing 1.5m high parapets.

On average across the ECML and WCML the number of bridges per track kilometre is around 0.42. If this rate was the same across the wider network where 13,000 STKs of electrification are proposed by TDNS this would equate to an additional total cost of £737m compared to the cost in providing 1.5m high parapets.

- 8.2.5 Battery and Hydrogen infrastructure costs have been allocated in line with the RSSB T1199 research study and are based around the location of interventions (i.e. at depot or in a termini) and the number of trains required to be serviced.
- 8.2.6 In total a capital investment of between £18bn and £26bn (2020 prices) would be required for infrastructure for the recommendations outlined in section 5.8. The pace at which decarbonisation is delivered results in various levels of annual cost.
- 8.2.7 In Figure 25 below the extent of funding required on an annual basis (in 2020 prices) for the various pathways considered as part of the Economic Case is shown.

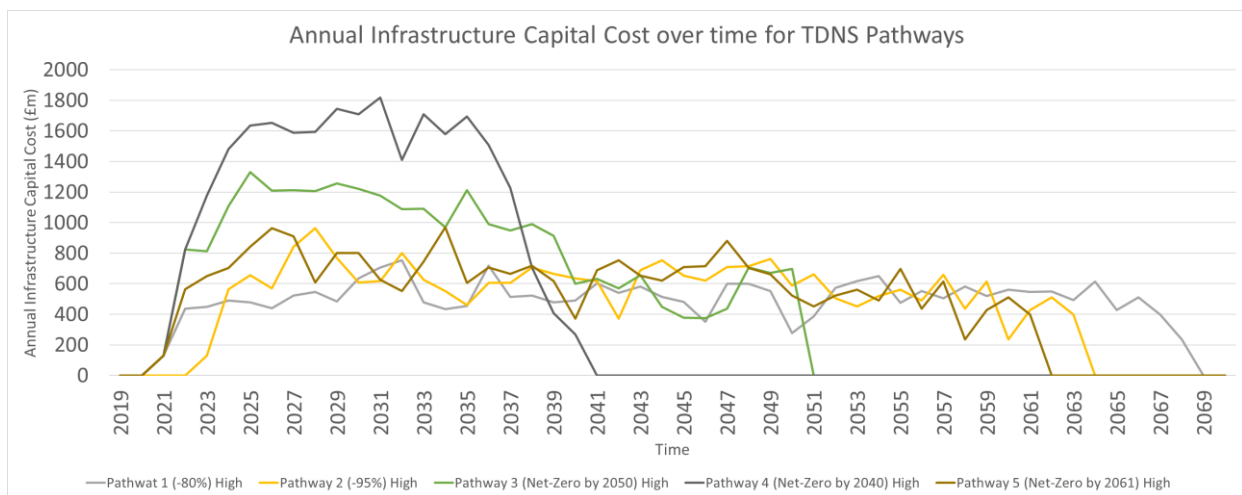

Figure 25: Annual infrastructure capital cost over time of TDNS pathways

- 8.2.8 For pathways 3, 4 and 5 all passenger emissions are removed with the residual emissions beyond the relevant end dates a result of freight train operation over unelectrified segments of the network. The residual emissions from these remaining services would either need to be offset, removed using an alternatively fuelled locomotive or by providing further electrification. Providing electrification in order to remove these services would require an additional 2,100 STKs of electrification with a capital cost increase of £3bn-£4bn (2020 prices).
- 8.2.9 Whilst rolling stock is not directly procured by government there will nonetheless be a capital expenditure required. Analysis of the recommendations suggests that between 3,600 and 3,800 electric and between 150 and 200 battery and hydrogen passenger units will be required for the end state network outlined across section 5.8.

8.2.10 As a programme of decarbonisation is defined as part of the TDNS PBC it is likely that areas where interim alternative traction solutions are required will be identified. This will increase the number of battery and hydrogen trains needed, though possibly only in the interim. Replacement for freight locomotives would likely take the form of a mixed fleet of straight electric and bi-mode rolling stock.

8.2.11 Whilst from an economic analysis perspective rolling stock costs are accounted for in lease costs there will nonetheless be an upfront capital cost required. Analysis suggests the capital cost of the rolling stock required to fulfil the recommendations outlined in section 5.8 for passenger is likely to be between £15bn-£17bn (2020 prices) with freight locomotives an additional £3bn-£4bn (2020 prices).

OPERATING COSTS

8.2.12 Operating cost savings will be realised as a consequence of the increasing share of non-diesel rolling stock on the network. For the purposes of the economic modelling, the following costs have been considered and modelled:

- staff costs;
- vehicle costs;
- fuel costs; and
- Track Access Charges.

8.2.13 Operating cost savings are directly impacted by TDNS projects as they remove diesel trains from the railway network. Cost savings have been estimated to be in the range of £12bn-£17bn (2020 prices) over the ninety-year period considered as part of this analysis.

8.2.14 Whilst operating costs for freight operations are not easily quantified due to the commercial nature of the freight industry, there are likely to be clear operational costs savings through operating pure electric locomotives compared with diesel. These will most likely be focused on fuel costs and other vehicle costs such as maintenance.

8.3 FINANCIAL CASE: CONCLUSIONS

The decarbonisation of all railway lines is dependent on achieving a balance between an optimum development and delivery of electrification and civil engineering works, and the need to make the best use of the available capital funding during the next Control Periods.

TDNS as it is proposed is expected to incur capital costs for infrastructure of between £18bn and £26bn (2020 prices). The median capital spend per year is between 18%-54% of CP6 enhancement budgeted levels in the low cost range and between 24%-72% in the high cost range. Rolling stock costs are expected to be between £15bn-£17bn (2020 prices) for passenger and a further £3bn-£4bn (2020 prices) for freight.

This results in a combined capital cost of £36bn-£47bn (2020 prices). These proposals result in a small level of residual diesel emission from freight services operating over unelectrified network segments. These emissions would either need to be offset, or removed using an alternatively fuelled locomotive or by providing further electrification. Providing further electrification would require a capital cost increase of £3bn-£4bn (2020 prices) to the upper cost estimate.

There will be additional operational costs on top of these, but compared with continued diesel operation it is envisaged that a £12bn-£17bn (2020 prices) cost saving for passenger operations could be achieved with further cost savings for the private freight operators.

The evaluation undertaken in the section reflects the current programme used for undertaking economic modelling of the delivery of TDNS recommendations. This will change as a more detailed programme of decarbonisation is provided as part of the TDNS Programme Business Case in October 2020. This section will be updated as part of the programme business case to reflect the programme established, although it is envisaged that any further work will produce costs which lie within the cost envelope outlined above.

9. MANAGEMENT CASE

9.1 MANAGEMENT CASE: SUMMARY

The successful delivery of TDNS will necessitate a well-planned and achievable programme scheduled around several milestones.

As there are multiple paths to achieve net-zero carbon emissions, the aim of this case is to make sure that the organisation in place to support and deliver TDNS projects is efficient and capable of hitting the required control points along the decarbonisation curve.

The TDNS programme will need to be managed and achievable to make the best possible use of public funding. The regional project leadership responsible for individual TDNS projects will need to work together with the industry to allow this programme to be achieved successfully.

The programme and outputs presented as part of this case reflect the current thinking as part of TDNS. Defining a programme of decarbonisation is complex and requires consideration of multiple priorities. Work is being undertaken by the TDNS team working with stakeholders from across the industry to define the programme of decarbonisation for TDNS. This will be provided in October 2020 as part of the TDNS PBC.

9.2 PROGRAMME OF DECARBONISATION

INFRASTRUCTURE REQUIREMENTS

- 9.2.1 The programme of decarbonisation details the activities, in the form of discrete projects, that need to take place to convert all the services currently specified as diesel-powered operations.
- 9.2.2 With over 13,000 STKs of electrification needed and recent supply chain activity averaging 450 STKs per year but having fallen to much lower levels, there is a clear challenge to re-build capability to the required volumes whilst maintaining the delivery efficiency that is currently being achieved. Following the publication of this document Network Rail will be working with the Network Rail regions, RIA and the supply chain in undertaking a market sounding exercise to validate the volume of delivery which can be efficiently achieved each year on a national scale and to understand how capability would be built up in order to deliver a successful decarbonisation programme.

9.2.3 As outlined in Table 14, and replicated below as Table 15, the potential volumes required to achieve net zero targets for 2040 appear ambitious compared with historic and delivery rates outlined as part of the RIA Electrification Cost Challenge. As noted, volumes of delivery seen historically during major electrification programmes such as East Coast in the late 1980s and more recently the CP5 electrification schemes saw an annual average delivery rate of between 300 to 450 STKs. This would suggest that achieving net zero by 2050 (Pathway 3) could be possible but to achieve this by 2040 is unrealistic without an unprecedented change in delivery capability.

Pathways	Average Annual STKs over programme	Maximum STKs in any one year
Pathway 1 (-80%)	259	377
Pathway 2 (-95%)	303	447
Pathway 3 (Net-Zero by 2050)	355	691
Pathway 4 (Net-Zero by 2040)	658	922
Pathway 5 (Net-Zero by 2061)	303	447

Table 15: Indicative electrification infrastructure volumes from economic modelling runs

9.2.4 The pathway programmes developed are indicative at this stage and further work is required to be undertaken with industry stakeholders to explore and provide a programme of decarbonisation to successfully implement to TDNS recommendations.

9.2.5 This market sounding exercise, coupled with further work with Network Rail and industry stakeholders, will provide a framework programme identifying the relevant priorities of the various interventions outlined in section 5.8. The prioritisation undertaken as part of the TDNS PBC will set out a programme informed by:

- carbon reduction contribution;
- air quality potential benefit (long term solution);
- contribution to decarbonisation of a wider journey;
- achieving homogeneity of a fleet or service group;
- rolling stock renewals;
- passenger aspiration priority;
- freight aspiration priority;
- impact on users; and
- operational considerations

ROLLING STOCK REQUIREMENTS

- 9.2.6 Cascade of the cleanest compliant diesel trains as these are displaced by electrification and alternative traction technologies will be required in order to achieve optimum carbon reductions and achieve interim targets outlined in Table 3. This cascade also has the potential to improve capacity in the short-term, mainly through providing longer trains. Eventually, after all diesel-only trains are removed from the network, it is expected that most cascaded units will be diesel/electric bi-modes to make the most of the increasingly electrified network.
- 9.2.7 The deployment of diesel /electric bi mode units will be essential in realising incremental benefits as the electrification element of the programme of decarbonisation is delivered as they will be able to progressively use electric traction more and more as greater volumes of electrification are provided resulting in progressive reduction in emissions.

OVERALL PROGRAMME OF DECARBONISATION

- 9.2.8 As it stands the programmes used for economic modelling purposes are broadly based on prioritisation from previous route utilisation study work undertaken by Network Rail and known stakeholder priorities. The programme has not been replicated here as the relative priorities require industry buy-in and agreement as well as a clear understanding as to the volumes of electrification which can be delivered on an annual basis.
- 9.2.9 This will be the focus of the TDNS Programme Business Case which will be completed in October 2020 and will outline a programme of decarbonisation. At this stage it is envisaged that this programme will take the form of a framework indicating a window of time in which a project would take place in accordance with the official carbon reporting windows. Initially each project will be assigned an arbitrary score whereby, if there is a desire to promote a scheme, a project or projects of total equal value must be demoted to allow the desired scheme to be promoted. The score attributed to the project will be in line with its relative complexity which was considered as part of the cost attribution process outlined in Section 8.2. An indication of what this might look like is provided in Figure 26 overleaf.

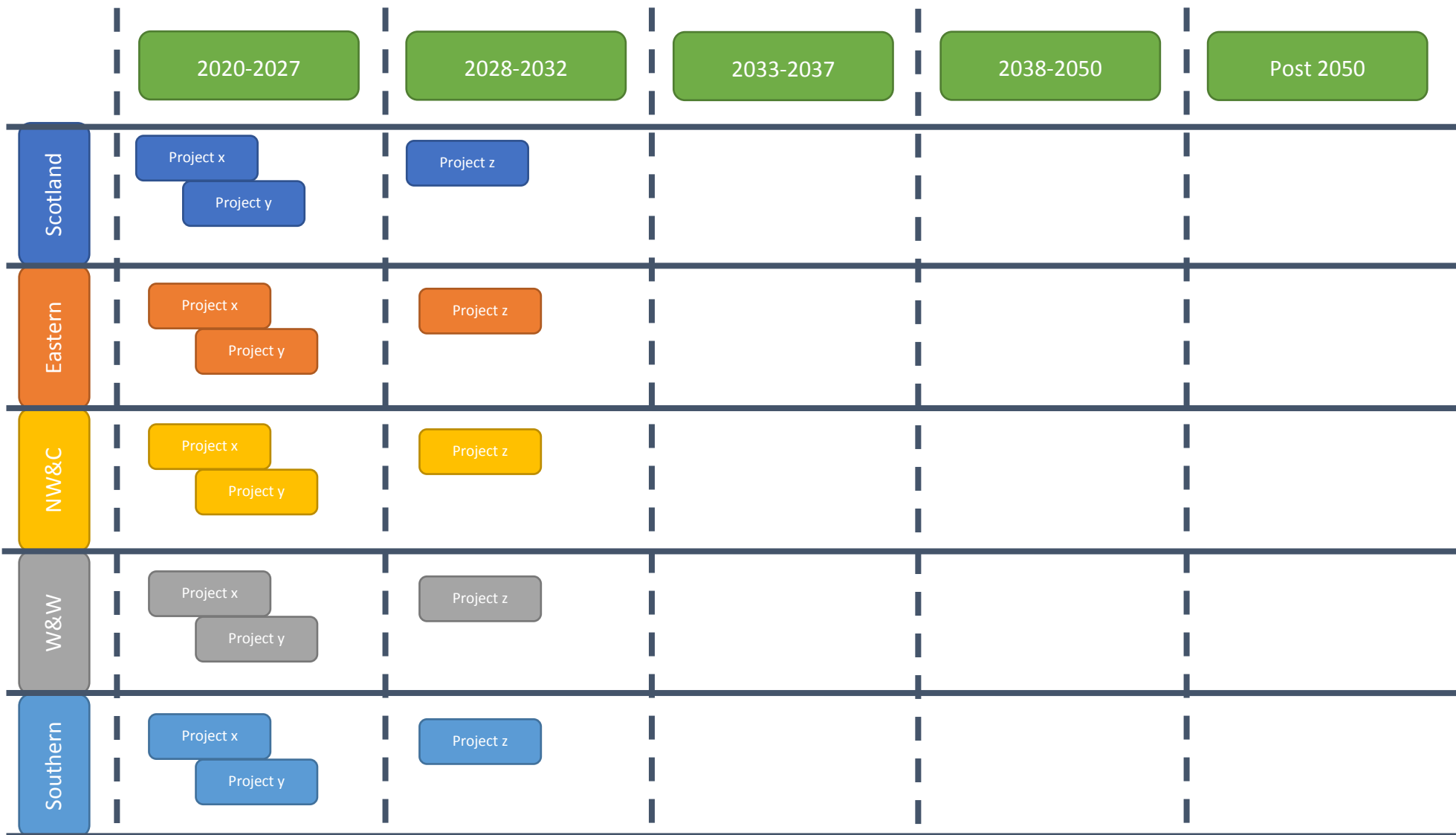

Figure 26 Indication of what the TDNS programme of decarbonisation may look like in the TDNS PBC

PROGRAMME DEPENDENCIES

- 9.2.10 The Transport Decarbonisation Plan (TDP), being prepared by the DfT, will be the main policy document governing transport decarbonisation in the UK. TDNS will directly inform the policies set out for rail in the plan. The TDP will consider policies to sustain decarbonisation through modal shift, and it is expected that the rail sector will represent the main public transport system capable of attracting private vehicle trips, especially in the medium- and long-distance categories.
- 9.2.11 It is expected that undertaking the TDNS recommendations will provide a significant boost to rail freight modal shift, as an energy-efficient and cost-effective way of moving goods along long distances. As the logistics industry is consolidating into larger warehousing facilities and distribution centres, rail freight is in the unique position where it can decarbonise the large part of container traffic while providing increased capacity and reliability compared with road transport.¹⁴⁶
- 9.2.12 There is scope for undertaking works related to TDNS electrification in conjunction with other enhancement projects. Specifically, TDNS projects along key freight corridors could explore the opportunity to deliver civil engineering works to achieve the W10, W12 and GB1 loading gauge aspirations set out in the Freight Network Study.
- 9.2.13 There are a number of other major programmes which TDNS will have to consider and align with. This will include the Long-Term Deployment Plan (Digital Railway), HS2, NPR and projects emerging as a result of the rail industry Air Quality Strategic Framework. These will be considered in greater detail in the TDNS PBC.
- 9.2.14 Several enhancement programmes could follow the successful delivery of TDNS in the long-term future. As skilled electrification development and delivery teams will need to transition to new activities once TDNS projects are completed, there is scope to consider the conversion of the legacy third rail electrification systems to OLE. Given the volume of electrification required for the unelectrified network it is highly unlikely that, if conversion were to happen at all, this would commence before 2050-2060 at the earliest.
- 9.2.15 There could be a need arising from the obsolescence of the electrification systems along those lines, and there could be an opportunity to upgrade at least part of the third rail lines to OLE to provide increased traction power, safer working conditions, reduced electricity losses and to support freight operations. This could also provide long term skills for electrification staff beyond the proposed programme.

¹⁴⁶ A McKinnon et al., 2010, Green Logistics: Improving the Environmental Sustainability of Logistics.

9.3 GOVERNANCE

9.3.1 TDNS is governed by a cross-industry board that has overseen the overall programme. Board members have been chosen to represent the breadth of Network Rail alongside representation from the DfT, Transport Scotland, Welsh Government, passenger and freight service operators, ROSCOs, RSSB, RFG and the Railway Industry Association to represent the priorities of the wider supply chain. The composition of the Programme Board is summarised in Figure 27 below. This also shows how the programme board is used to onward brief the wider rail industry.

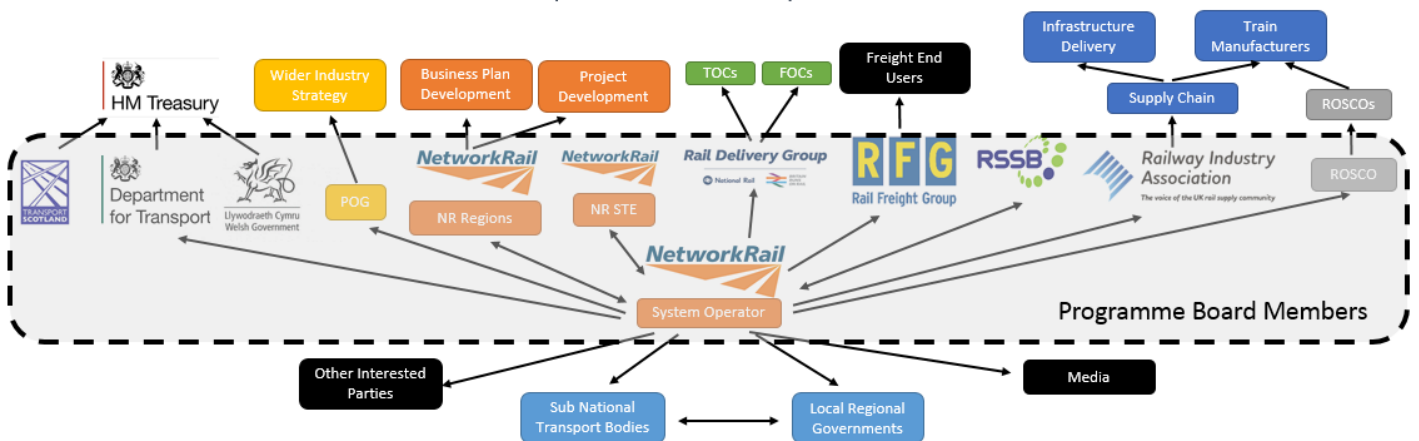

Figure 27: TDNS Programme Board composition and relationship with wider industry

9.3.2 The delivery of TDNS is devolved to NR regions and is subject to funding from HM Government, the Scottish Government, and the Welsh Government. Individual projects will be governed by the RNEP and GRIP processes.

9.4 PROJECT BUSINESS CASE DEVELOPMENT

9.4.1 The TDNS Programme Business Case aims to cover all pre-GRIP discussions, especially concerning the strategic case for decarbonisation and the need to address climate change for all sectors of society.

9.4.2 Individual NR Regions will own the development of TDNS projects falling within their geographical boundaries.

REGIONAL LEADERSHIP

9.4.3 The remit of TDNS is to provide decarbonisation options for the DfT, Transport Scotland and Welsh Government by examining the suitability of different traction options for each part of the rail network, and the cost and timing of their possible deployment.

- 9.4.4 The programme informs the government as to the scale and pace of rail decarbonisation between now and 2050, while the Transport Decarbonisation Plan will integrate TDNS findings within a cross-modal plan for a decarbonised future transport system.
- 9.4.5 Individual schemes will be developed through the RNEP to deliver an affordable and deliverable discrete segmentation of decarbonisation. GRIP will govern individual TDNS projects, while the Programme Business Case aims to definitively cover the entirety of the pre-GRIP stage. It is envisaged that Regional teams will be able to utilise the TDNS PBC when compiling discrete business cases ideally allowing time to be saved in the SOBC/SOC stage of project development.
- 9.4.6 Different approaches may be required to electrify lines in different parts of the country as a result of geographic and topological differences of the network.
- 9.4.7 The regional delivery teams will make decisions regarding the cost, appropriate standards, design, power supply and delivery methodology for each TDNS project. These will be specified for the level of service necessary to each decarbonisation project. The option appraisal stage will have to critically review each option against the required performance, leaving reasonable flexibility on the specifications.

LEARNING LESSONS FROM PREVIOUS PROJECTS AND OVERSEAS DEPLOYMENT

- 9.4.8 TDNS is committed to using all the experience from previous and ongoing electrification projects in Britain and abroad. All TDNS projects will need to follow the best practices around efficient electrification from inception.
- Realistic programme targets.
 - Mature estimates.
 - Proven technologies.
 - Optimised design.
 - Strong technical leadership.
 - Lean programme management.
 - Output specification.
- 9.4.9 These are extensively discussed in the Electrification Cost Challenge report produced by RIA in July 2019 and revolve around choosing to optimise the performance outputs, versus only specifying the technical inputs, during all phases of any electrification project.

9.4.10 As battery and hydrogen trains enter operational service it will be critical to ensure lessons are captured and learned across the industry. There are also a number of lessons which have been learned so far as the technologies have emerged. These include:

- clear system specification definition, buy-in from all stakeholders;
- understanding of the desired outcomes and contractual and commercial structure needed for successful implementation;
- integrated approach for hydrogen fuel provision and distribution to ensure best overall value for money; and
- sufficient time is allowed for planning, consents and approvals.

9.5 FURTHER SYNERGIES

9.5.1 This document has begun to outline a number of areas where further work may be required. A comprehensive recommendation for further areas of work will be provided as part of the TDNS PBC. At this stage it is envisaged that as a minimum this will include the below areas.

- Greater understanding of the power shortfalls of the existing electrified network and the role of regional traction power strategies.
- Understanding the procurement mechanisms for freight locomotives.
- Identification of the characteristics of existing diesel and diesel bi-mode rolling stock and establishing a cascade hierarchy as vehicles are released as a result of the deployment of the programme of decarbonisation.
- Development of regional delivery strategies for electrification, including how best to engage with the supply chain and the commercial arrangements this will entail.
- Establishing the benefits and practicalities of multi-modal refuelling and recharging hubs.
- Consideration of how electrification needed for freight services is integrated with freight depots, terminals, etc. and the associated operational impacts.

9.6 MANAGEMENT CASE: CONCLUSIONS

The programme of delivery for the recommendations made as part of this Interim Programme Business Case is a clear focus for the TDNS PBC which will be complete in October 2020. Network Rail will continue to work with the industry and supply chain to define this programme and prioritise the infrastructure and rolling stock interventions which will be required to achieve traction decarbonisation.

Whilst at an early stage, this case (along with the preceding commercial and financial cases) has demonstrated the enormity of the challenge of delivering traction decarbonisation. The cases have also demonstrated that it is possible to achieve this within cost and time envelopes if required. Whilst the TDNS PBC work is ongoing it is envisaged that a number of early schemes will begin to emerge, and these will be factored into the decarbonisation programme. Equally the opportunity to achieve synergies with in-flight programmes such as the Trans-Pennine Route Upgrade will be critical.

The governance framework which has been established as part of the development of TDNS and the role of key industry stakeholders in overseeing this work has been invaluable. As discrete projects continue to be developed and delivered this engagement should continue at both a local and national level.

There are a number of areas of further work which will be required following the completion of the TDNS as it will not provide a full suite of answers. As technologies mature and the programme of decarbonisation begins to be delivered, progress will be required to be checked and validated and as such TDNS is envisaging being refreshed on a five-yearly basis. There will undoubtedly be other areas where further work is required and the impacts of clear policy choices and targets as part of work led by UK Governments will outline any further considerations required.

APPENDIX 1 – NETWORK RAIL REGIONS AND SERVICE OVERVIEW

SCOTLAND'S RAILWAY

The Scotland's Railway Region contains only one Route (Scotland Route). Scotland's Railway is responsible for the entire railway in Scotland from the England-Scotland border to the Far North.

Significant investment in electrification has taken place in Scotland over the past five to ten years, with a large volume of route kilometres electrified. This has principally focused around electrification of key routes between Glasgow and Edinburgh, and the wider Central Belt of Scotland. Both the main cross-border routes into Scotland on the West Coast Main Line (WCML), and East Coast Main Line (ECML) are also electrified.

Beyond the wider Central Belt, and to the border with England, very little of the railway in Scotland is currently electrified; and a number of diesel services operate between the major cities including Aberdeen, Dundee, Inverness, Perth and Stirling and into Glasgow and Edinburgh.

Away from the major cities a number of branch lines are found with lines from Inverness to Wick, Thurso and Kyle of Lochalsh in the Far North and lines from Glasgow to Oban and Fort William in the North West; and Stranraer and Dumfries in the South West.

Freight flows are primarily cross-border, with many domestic intermodal services originating from England, travelling to the Central Belt and North. There are also a number of intra-Scotland flows. Scotland is seeking to grow rail freight significantly and already regularly exports timber and spirits in reverse workings to England.

Rail in Scotland has devolved accountability to the Scottish Government. As a result, funding and investment decisions are the responsibility of Transport Scotland (TS). The Scottish Government has revised its climate change legislation, committing Scotland to a net zero GHG emissions target by 2045. As part of a decarbonisation programme for Scotland, TS is seeking to decarbonise the traction of domestic passenger services in Scotland by 2035.

EASTERN

Eastern comprises four routes: Anglia, East Coast, East Midlands and North and East. It is the largest region, both in terms of total route kilometres and also unelectrified route kilometres. As a result, it is also the largest CO₂ emitting region for direct diesel emissions. These routes and the railway contained within them are summarised below.

ANGLIA

A large proportion of the network on the Anglia route is electrified. This includes each of the three main lines to and from London: the Great Eastern Main Line (GEML) and West Anglia Main Line (WAML) to and from London Liverpool Street station and the Thameside route to and from London Fenchurch Street. Orbital routes within London are also nearly all electrified.

‘Regional’ routes in Norfolk and Suffolk are unelectrified, however, and are operated by either diesel or diesel-bi mode trains (which are currently being introduced to replace the whole diesel-only fleet). ‘Cross-country’ routes, such as those from between Ely and Norwich and between Felixstowe and Peterborough, are also unelectrified.

Major freight flows operate between Felixstowe and London and Peterborough. Whilst a number of the Felixstowe to London flows use electric traction from Ipswich, all other flows via Peterborough operate under diesel traction. There are equally significant intermodal, aggregate and construction flows from the Essex Thameside area from London Gateway and Tilbury.

EAST COAST

The East Coast Main Line (ECML) is fully electrified from King’s Cross to the Scottish Borders running through the cities of Peterborough, Doncaster, York and Newcastle. This allows all of the commuter networks into London King’s Cross to be operated electrically.

Freight services on the ECML are operated using diesel traction, even though the route is electrified throughout. This is principally due to the fact that their origins or destinations are away from the electrified ECML or they are routed on unelectrified sections away from the ECML. There are also power limitations on the most northern part of the network.

A number of bi-mode passenger services also operate on the East Coast which originate from non-electrified destinations in England and Scotland, as well as diesel services serving TransPennine and cross-country markets on the northern sections of the route as well as some services from the North East to London.

EAST MIDLANDS

The main backbone of the East Midlands is the Midland Main Line (MML), which still operates long-distance high-speed services using diesel rolling stock. Part of the MML from Market Harborough to London is now electrified (or committed to be electrified), which allows Thameslink services and regional commuter services from Corby and Kettering into London St Pancras and central London to be operated electrically. Plans are emerging to replace diesel long-distance high-speed rolling stock with diesel-electric bi-mode units, which will also be able to utilise electrification to Market Harborough.

A large number of regional services in the East Midlands between the major conurbations of Derby, Nottingham, Sheffield, Doncaster, Peterborough and Lincoln are diesel-operated.

Freight services from Anglia operate across the East Midlands route, including through Lincolnshire towards Doncaster and the East Midlands towards Nuneaton and Birmingham. There are also significant aggregates flows from quarries in the East Midlands into London and other major urban areas.

CrossCountry services use the ECML between Edinburgh, Newcastle and York, but also operate on the unelectrified corridors between York, Leeds, the Midlands and Birmingham. These services are operated by diesel trains throughout.

NORTH AND EAST

The North and East route covers all the local and regional services north of Doncaster. This includes regional commuter services to a large number of major urban areas including Leeds, York, Hull and Newcastle.

There are also a number of major freight flows from a number of ports to the Midlands and Scotland.

Major east/west flows operate across the Pennines between Manchester and Leeds. Almost all these services are diesel-operated, and the extent of electrification is minimal in the North and East Route, with only the main route between Doncaster and Leeds electrified.

SOUTHERN

Southern comprises four Routes: Kent, Sussex, Wessex and High Speed 1 (HS1). The Kent, Wessex and Sussex Routes are mostly electrified with 750V DC third rail, with the HS1 route electrified using 25kV AC overhead line. Since electrification of the conventional network, which was undertaken mostly in the post WWII era, the deployment of further third rail infrastructure has been limited. A workstream jointly led by Network Rail, RSSB and ORR is exploring the opportunity to provide new infill third rail electrification. A summary of the key flows for each route is summarised below.

KENT

Kent principally provides regional commuter services into London Victoria and Charing Cross. A number of cross-regional flows can be found away from London, linking up major towns and cities in the Kent region.

The only unelectrified route within Kent for passenger services is between Ashford and Hastings. Branches to the Isle of Grain and Dungeness are also unelectrified but are

currently used exclusively by freight. There are aspirations to re-introduce passenger services to the Isle of Grain.

Most freight services currently operate on diesel traction as there is a very limited pool of freight locomotives able to use third rail as a tractive method, with operating restrictions in place in some locations.

SUSSEX

Sussex Route provides regional commuter services into London Victoria and other central London stations through the Thameslink core. The principal route within Sussex is from Brighton into central London via Gatwick airport.

Almost all services again are electric, with the only exceptions being services using the line between Guildford, Dorking and Redhill, and the Uckfield branch.

There are limited freight flows within Sussex, but there are some aggregates services.

WESSEX

Wessex similarly provides regional commuter services into London Waterloo. Unlike the other two routes, whilst links between Weymouth, Southampton and Portsmouth as well as to Basingstoke are electrified using third rail, a number of routes are operated by diesel trains, including those operating beyond Basingstoke both to Reading and Exeter and services north from Southampton to Salisbury and Westbury.

There are a large number of freight flows, operating principally from the ports on the south coast. This is a mixture of intermodal and automotive traffic. Aggregates flows are also found from quarries in the Western route. All freight operates using diesel locomotives.

HIGH SPEED 1

High Speed 1 is the rail link between the Channel Tunnel and London St Pancras International. It is used by Eurostar services from mainland Europe and a domestic high-speed service serving Ebbsfleet, Ashford and other towns within Kent. Domestic services are operated by fully electric AC/DC rolling stock in order to utilise the 25kV overhead line on the high-speed network and the 750V DC third rail on the conventional network.

Rail freight entering the UK directly from Europe accesses via the Channel Tunnel and can access London via HS1 or via the conventional routes through Kent.

WALES AND WESTERN

The Wales and Western Region has a broad geographic scope and has significant volumes of unelectrified railway. Until recently it contained one of the largest unelectrified long-distance-high-speed networks in the UK.

This has changed through the investment made to the route as part of the Great Western Electrification Programme electrifying the Great Western Main Line (GWML) from London Paddington to Chippenham, Bristol Parkway and Cardiff. Through the introduction of new diesel-electric bi-mode trains (Class 800 and 802) significant proportions of passenger journeys are now made with electric traction, realising environmental and journey time benefits when compared with the previous Intercity 125 (HST) trains which they replaced.

WALES

Almost all the railway in Wales is unelectrified, with only the Great Western Main Line into Cardiff providing electric services. The transition of the Cardiff Valley Lines from Network Rail to the Welsh Government will see them fully or partly electrify the lines to provide a metro-style service into Cardiff. Beyond this, all other services operate under diesel traction including Great Western intercity services to Swansea.

There are a number of significant freight flows from Central Wales and the South Wales coast to North Wales and England; this is mostly steel, oil and aggregates traffic.

WESTERN

Despite extensive electrification as outlined above there remain a number of services on the Great Western Main Line which continue to operate with diesel traction. Services provided by diesel electric bi-mode trains use diesel traction when away from electrified infrastructure when serving Oxford, Bath and Bristol Temple Meads. The railway from Bristol to Penzance is a significant length and is also operated fully by diesel or diesel bi-mode trains. A number of regional lines to coastal towns in Devon and Cornwall branch off this route.

A number of major aggregate flows originate from the Western route, which provide significant volumes of material both to the London and wider UK construction industry. Intermodal flows from the South coast utilise the GWML between Reading and Didcot on route to the West Midlands.

Similarly to the Eastern region, there are significant CrossCountry flows which currently operate as diesel services despite the extensive electrification programme. These are principally services from Birmingham to Devon and Cornwall as well as to Oxford, Reading and the south coast.

NORTH WEST AND CENTRAL

North West and Central Region comprises three routes: North West, Central and West Coast Main Line South. With a number of major cities throughout the region, this area is one of the busiest parts of the rail network outside London.

WEST COAST MAIN LINE SOUTH

Like the East Coast Main Line (ECML), the West Coast Main Line (WCML) is electrified and is used by a mixture of long-distance high-speed services to Birmingham, Manchester, Liverpool and Scotland as well as supporting a significant suburban commuter market Milton Keynes, Rugby and Coventry to London and Birmingham. Despite the West Coast being electrified throughout, a number of long-distance high-speed services serving destinations off the WCML operate as diesel throughout, although plans are emerging to replace these with diesel-electric bi-mode units.

The WCML is the major electric freight artery between England and Scotland and almost all the UK rail freight which is electrically hauled operates on this corridor. The WCML is one of the busiest freight routes on the UK network.

CENTRAL

Separate from the WCML, but roughly parallel, the Chiltern Main Line runs from London to Birmingham via Oxford and Leamington Spa. This line is diesel operated throughout, with a mixture of regional commuter traffic and longer distance services. The section of the route between Banbury and Birmingham is a major corridor for freight from south coast ports to destinations in the Midlands and north of England.

Similarly to Eastern Region and Western and Wales Region there are CrossCountry flows which operate with diesel traction. These are principally services from Birmingham to Oxford, Reading and the south coast.

Whilst a significant proportion of the suburban rail network into Birmingham is electrified there are a number of areas which are not, in particular services into Birmingham Snow Hill from both north and south.

NORTH WEST

As well as containing the northern portion of the WCML, this Route also includes the major commuter networks into Manchester and Liverpool. A proportion of these networks is electrified, including the Merseyrail 750V DC third rail network in Liverpool, but there remains significant and widespread diesel operation.

The WCML is the major electric freight artery between England and Scotland and almost all the UK rail freight which is electrically hauled operates on this corridor. The WCML is one of the busiest freight routes on the UK network.

Away from the major cities, routes across the Pennines and through the Lake District, Lancashire and Cumbria provide rural services as well as freight flows, all with diesel traction.

APPENDIX 2 – ROLLING STOCK TABLES

The table below shows the diesel rolling stock considered as part of this work and the operators at the time of analysis (Summer 2019 Timetable). This was the known position at the time and a number of rolling stock moves and scrappages have occurred in the time since. This includes diesel bi-mode passenger rolling stock.

Class	Traction	Formation	Entry Year	Operators
139	Flywheel	1 car	2007-08	WMR
142	D	2 car	1985-87	NR, TfW
143	D	2 car	1985-86	TfW, GWR
144	D	2 or 3 car	1986-87	NR
150	D	2 or 3 car	1984-87	GWR, NR, TfW
153	D	1 car	1991-92	NR, EMT, TfW, GA
155	D	2 car	1988	NR
156	D	2 car	1987-89	EMT, GA, NR, SR
158	D	2 or 3 car	1990-92	SR, NR, TfW, GWR, EMT, SWR
159	D	3 car	1991-93	SWR
165	D	2 or 3 car	1990-93	CR, GWR
166	D	3 car	1992-93	GWR
168	D	3 or 4 car	1997-06	CR
170	D	2 or 3 car	1998-05	CC, GA, SR, SR, WMR
171	D	2 or 4 car	2000-05	GTR
172	D	2 or 3 car	2010-11	CR, WMR
175	D	2 or 3 car	1999-01	TfW
180	D	5 car	2000-01	GC, FHT
185	D	3 car	2005-07	TPE

Class	Traction	Formation	Entry Year	Operators
195	D	2 or 3 car	2018-20	NR
220	D	4 car	2000-01	CC
221	D	5 car	2001-02	AWC, CC
222	D	4, 5 or 7 car	2004-05	EMT
230	D/B Bi	2 or 3 car	2019	Vivarail, WMT, Tfw
755	D/E Bi	4 or 5 car	2019-20	GA
769	D/E Bi-Tri	4 car	2019-20	NR, GWR, Tfw
800	D/E Bi	5 or 9 car	2017-19	GWR, LNER
802	D/E Bi	5 or 9 car	2017-20	GWR, TPE, FHT

The table below shows the electric rolling stock considered as part of this work and the operators at the time of analysis (Summer 2019 Timetable). This was the known position at the time and a number of rolling stock moves and scrappages have occurred in the time since.

Class	Traction	Formation	Entry Year	Operators
313	E (AC-DC)	3 car	1976-77	GTR, Network Rail
314	E (AC)	3 car	1979-80	SR
315	E (AC)	4 car	1980-81	LO, TfL
317	E (AC)	4 car	1981-86	GA, LO
318	E (AC)	3 car	1985-86	SR
319	E (AC)	4 car	1987-90	NR, WMR, Off-lease
320	E (AC)	3 car	1990	SR
321	E (AC)	4 car	1988-91	NR
322	E (AC)	4 car	1990	NR
323	E (AC)	3 car	1992-93	NR, WMR
325	E (AC)	4 car	1995-96	DB Cargo

Class	Traction	Formation	Entry Year	Operators
331	E (AC)	3 or 4 car	2018-20	NR
332	E (AC)	4 or 5 car	1997-02	BAA, GWR
333	E (AC)	4 car	2000-03	NR
334	E (AC)	3 car	1999-02	SR
345	E (AC)	9 car	2017-19	TfL
350	E (AC)	4 car	2004-09	WMR, TPE
357	E (AC)	4 car	1999-02	C2C
360	E (AC)	4 or 5 car	2002-06	GA, HC, GWR
365	E (AC)	4 car	1994-95	GTR
373	E (AC)	10 car	1992-96	Eurostar
374	E (AC)	16 car	2015-18	Eurostar
375	E (DC-AC)	4 car	1999-04	SE
376	E (DC)	5 car	2004-05	SE
377	E (DC-AC)	3 or 4 car	2001-14	GTR, SE
378	E (DC-AC)	5 car	2009-11	LO
379	E (AC)	4 car	2010-11	GA
380	E (AC)	3 or 4 car	2010-11	SR
385	E (AC)	3 or 4 car	2017-19	SR
387	E (AC-DC)	4 car	2014-18	GTR, C2C
390	E (AC)	9 or 11 car	2001-11	AWC
395	E (AC-DC)	6 car	2007-09	SE
397	E (AC)	5 car	2018-19	TPE
399	E (AC-DC)	3 car	2017-18	SST
442	E (DC)	5 car	1988-89	SWR, Off-Lease

Class	Traction	Formation	Entry Year	Operators
444	E (DC)	5 car	2003-04	SWR
450	E (DC)	4 car	2002-09	SWR
455	E (DC)	4 car	1982-85	SWR, GTR
456	E (DC)	2 car	1990-91	SWR
458	E (DC)	5 car	1999-02	SWR
465	E (DC)	4 car	1991-93	SE
466	E (DC)	2 car	1992-94	SE
483	E (DC)	2 car	1989-90	SWR
507	E (DC)	3 car	1978-80	MR
508	E (DC)	3 car	1978-80	MR
700	E (AC-DC)	8 or 12 car	2015-18	GTR
707	E (DC)	5 car	2015-18	SWR
710	E (AC-DC)	4 car	2018-19	LO
717	E (AC-DC)	6 car	2018-19	GTR
720	E (AC)	5 or 10 car	2019-20	GA
745	E (AC)	12 car	2019-20	GA
801	E (AC)	9 car	2017-19	LNER

The table below shows the freight locomotives considered as part of this work and the operators at the time of analysis (Summer 2019 Timetable). This was the known position at the time and a number of rolling stock moves and scrappages have occurred in the time since.

Class	Traction	Entry Year	Operators
20	D	1957-98	HNR, GBRf, DRS, Private Owner
33	D	1960-62	WCR
37	D	1960-96	Colas, HNR, DRS, Network Rail, EP, WCR, ROG, LSL

Class	Traction	Entry Year	Operators
43	D	1976-82	GWR, EMT, SR, LNER, CC, Network Rail, Off-lease
47	D	1965-95	WCR, Nemesis Rail, LSL, HNR, GBRf, ROG, VT, Private Owner
50	D	1967-68	GBRf, Private Owner
56	D	1976-84	UKRL, GBRf, Colas, DCR, EP
57	D	1998-05	WCR, DRS, GWR
59	D	1985-95	FL, GBRf, DBC
60	D	1989-93	DBC, GBRf, DCR
66	D	1998-14	DBC, DRS, FL, GBRf, Colas
67	D	1999-00	DBC, Colas
68	D	2014-17	DRS, CR, TPE
70	D	2009-17	FL, Colas
73	D	1965-2016	GBRf, Network Rail, GTR, SWR, CS
86	E (AC)	1966	FL, Private Owner
88	E/D Bi (AC)	2016-17	DRS
90	E (AC)	1987-90	GA, FL, DBC
91	E (AC)	1988-91	LNER
92	E (AC-DC)	1993-95	DBC, GBRf

APPENDIX 3 – DECARBONISATION PROGRAMME (NON-TRACTION)

The Decarbonisation programme (non-traction) workstreams are outlined in greater detail below:

- **Road Fleet** – understanding how to decarbonise vehicles which Network Rail operations use to respond to incidents and maintain the railway.
- **Renewable Energy Generation and Storage** – identifying opportunities for Network Rail to generate its own energy to feed traction systems and buildings. A number of stations now have solar panels, and a trial is currently underway in Aldershot where solar panels are directly feeding the third rail traction system.
- **Managed Station Energy Use** – Network Rail manages twenty of the biggest and busiest stations on the network. This workstream is understanding how energy efficiency improvements can be made in these large, complex environments
- **Improving General Energy Efficiency** – a number of Network Rail assets use power supplies, including signalling, point heating and other equipment. This workstream is understand how efficiency can be realised in management of these assets
- **Electricity Connections to the Network** – this project explores how Network Rail buys its electricity and ensures it is from a sustainable source. With the need to provide electrical enhancement for both traction and non-traction purposes this workstream is looking at Network Rail’s relationship with National Grid and Distribution Network Operators (DNOs) on a longer-term basis.
- **Sustainability Culture** – this workstream is exploring how a general sustainability culture can be instilled in everything done by Network Rail. It looks at the behavioural and organisational changes required and how these can be achieved.

Ultimately, by 2025 Network Rail is aiming to:

- buy 100% renewable electricity without incurring additional costs;
- have a sustainability-aware, competent workforce capable of applying energy saving techniques as part of business as usual;
- manage power outages effectively, reducing costs and impacts on our customers;
- recover costs appropriately from third parties who use our energy; and
- include low whole-life carbon as a core requirement in design and construction of property and infrastructure.

By 2030, Network Rail is aiming to:

- directly feed electricity from renewable generation to traction and non-traction assets;
- use energy storage to manage load and help balance the National Grid, generating income and improving resilience; and
- have a road vehicle fleet that is transitioning towards electric power.

APPENDIX 4 – SUB-REGIONAL CONTEXT AND EMISSIONS TARGETS

This appendix provides a summary of the main decarbonisation and air quality strategies and targets for the Sub-National Transport Bodies.

Transport for the North (TfN)

Representative body for the North East, Cumbria, North West, Yorkshire and Humberside.

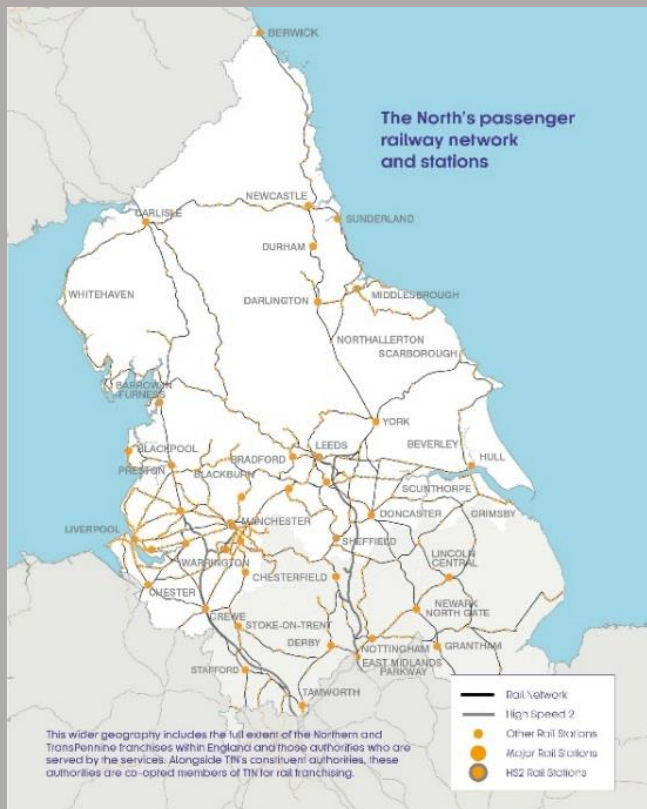

Strategic Transport Plan – “One North”

Connecting people:
leisure/tourism access & widening labour market for businesses

Connecting businesses:
connections between collaborators, clients & competitors

Moving goods:
supporting businesses to move freight efficiently

Decarbonisation Plans

- TfN developing a ‘Pathway to 2050’.
- SNTB has already committed to offset any emissions from the planned growth.
- Electrification is being considered where necessary to enable the strategic outputs.

Local Clean Air Zones (CAZ)

- Greater Manchester: 10 local authorities building CAZ from 2021
- Newcastle, Gateshead and North Tyneside from 2021
- Leeds from 2020
- Rotherham & Sheffield from 2021
- York from 2020

Major Rail Programmes

Transpennine Route Upgrade (TRU): principal intervention between Manchester and Leeds Corridor

Northern Powerhouse Rail: Mix of new and upgraded railways lines

Local Decarbonisation Plans

- Liverpool – Zero carbon target 2040
- Greater Manchester – carbon neutral 2038
- Sheffield City Region – Net Zero by 2040

Midlands Connect



Representative body for East and West Midlands and Lincolnshire.

Strategic Transport Plan

Aims to establish a 25-year rolling programme:

- 736 extra passenger services daily
- 72 extra freight trains daily
- 60 new stations

Midlands Engine Rail: 7 distinct schemes integrated with HS2 (£3.5 billion plan)

England's Economic Heartland

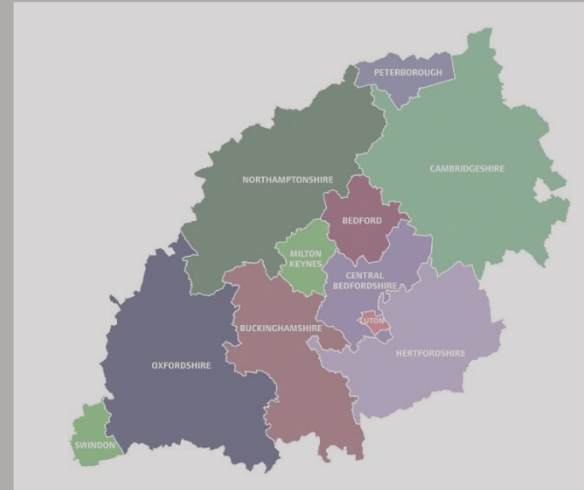

Representative body for Central Southern England.

Strategic Transport Plan

- Realising economic opportunities through improved intra-regional connectivity
- Improving quality of life and wellbeing through enhanced local connectivity
- Improving access to markets through strategic connectivity

Decarbonisation Plans

- Modal shift to rail to support UK 2050 target
- Electrification needed as a key enabler
- Committed budget of £600 million for partial electrification of Midlands Mainline

Local Clean Air Zones (CAZ)

- Birmingham from 2020
- Leicester from 2021

Local Decarbonisation Plans

- Birmingham reduce carbon emissions by 60 % by 2027
- Nottingham carbon neutral by 2028

Decarbonisation Plans

- Aiming to achieve net-zero carbon by no later than 2050

Local Decarbonisation Plans

- Low Carbon Oxford – 40 % reduction by 2020

Local Clean Air Zones (CAZ)

- Broxbourne from 2022
- Oxford – Zero Emission Zone (ZEZ) from 2021

Major Rail Programmes

East-West Rail: Linking East Anglia with Oxford via Cambridge

Transport East



Transport East

Representative body for Norfolk, Suffolk and Essex.

Decarbonisation Plans

- Currently in development

Local Clean Air Zones (CAZ)

- None currently but two in consultation:
 - Basildon
 - Rochford

Local Decarbonisation Plans

- None currently identified

Strategic Transport Plan

Global Gateways:

Better connected ports and airports to help UK businesses thrive and boost the nation's economy through greater access to international markets and facilitates Foreign Direct Investment.

Multi-Centred Connectivity:

Enhanced links between our fastest growing places and business clusters; enabling the area to function as a coherent economy and improving productivity.

Energised Coastal Communities:

A reinvented, sustainable coast for the 21st century which delivers on our ambition to become the UK's foremost all-energy coast, as well as a competitive visitor offer

Transport for London



Transport Authority for Greater London including all 32 boroughs and the City.

Decarbonisation Plans

- Committed to Net Zero emissions by 2050
- Plans to reduce emissions by 60 % by 2025

Local Clean Air Zones (CAZ)

- ULEZ charging introduced in 2019 with geographic extension expected from 2021

Strategic Transport Plan

- Connectivity and Housing
- Wants devolution of local stopping rail services to TfL control after successes of London Overground; argues would better integrate with TfL services

Major Rail Programmes

Crossrail 1 (Elizabeth Line)

New East-West link between Shenfield and Reading

Crossrail 2

New North-South link between Hertfordshire and Surry

Transport for the South East

Western Gateway



Representative body for Kent, Sussex and Wessex.

Western Gateway
Sub-national Transport Body

Representative body for Wiltshire, Gloucester and North Somerset

Strategic Transport Plan

- **Economy:** improve productivity and attract investment to grow our economy and better compete in the global marketplace
- **Society:** improve health, safety and wellbeing, quality of life, and access to opportunities for everyone
- **Environment:** Protect and enhance the South East's unique natural and historic environment

Local Clean Air Zones (CAZ)

- Portsmouth from 2021

Decarbonisation Plans

- Looking to commit to a reduction in carbon emissions to net zero by 2050 to minimise the contribution of transport and travel to climate change

Strategic Transport Plan

- Improve metro system
- Access to ports e.g. Poole and airports

Local Clean Air Zones (CAZ)

- Bath and North East Somerset from 2021
- Bristol from 2021

Local Decarbonisation Plans

- Bristol carbon neutral by 2030

Peninsular Transport



Representative body for Somerset, Devon and Cornwall

Local Decarbonisation Plans

- Brighton & Hove carbon neutral by 2030

Local Decarbonisation Plans

- Exeter Net zero by 2030

Local Clean Air Zones (CAZ)

- None currently identified

APPENDIX 5 – STRATEGIC AND ECONOMIC BENEFITS

The table below outlines which of the strategic benefits outlined within the strategic case are taken forward into the economic appraisal and those that are only considered qualitative at this stage.

Benefit	Case	Rationale
Long-term emissions reduction	Strategic and Economic	Considering the effects of emissions both strategically and economically is critical.
Diesel multiple unit and bi mode cascade	Strategic	Unit cascades will be discrete and localised as projects are implemented. This should be considered in project business cases following TDNS.
Passenger safety improvements on road	Strategic and Economic	Included as part of non-user benefits but inclusion is limited due to focus on direct decarbonisation rather than specifically model shift.
Decrease in road maintenance	Strategic and Economic	Included as part of non-user benefits but inclusion is limited due to focus on direct decarbonisation rather than specifically model shift.
Decrease in road congestion	Strategic and Economic	This has been included as part of the potential modal shift benefits calculated under TAG.
Cross modal transport economy of scale	Strategic	Economies of scale would reduce cost of technologies for rail. Capital cost changes.
Journey time decrease and possible capacity increase	Strategic and Economic	Captured economically for passenger services through improved acceleration of alternative stock vs diesel. Strategic only for freight.
Improved reliability and resilience	Strategic and Economic	Captured through improved Miles per Technical Incident values of alternative rolling stock, for passenger and freight, compared with diesel and their impact on passenger journeys.

Benefit	Case	Rationale
Passenger Experience	Strategic	Limited relevance at programme level appraisal from an economic perspective.
Rolling Stock initial capital cost	Strategic and Economic	Captured through lease costs of rolling stock. Excludes freight rolling stock.
Variable Track Access Charges	Strategic and Economic	Captured through changes in weight compared with diesel using NR VTAC and EAUC calculations.
Ongoing Operating costs	Strategic and Economic	Fuel costs captured through passenger operating costs.
Rolling Stock maintenance costs	Strategic and Economic	Costs included based on route mileage.
Rail Safety	Strategic	Difficult to quantify to include economically but the benefit would be realised.
Air Quality	Strategic	Whilst indication from the rail industry Air Quality Strategic Framework are that air quality economic benefits are likely to be significant; they have not been included in the economic case for TDNS as it is expected that short-term projects will realise these benefits in advance of TDNS projects being delivered. For TDNS projects which rectify an air quality issue it is recommended these are considered and included in discrete business case economic analysis. Further considerations around air quality benefits will be made as part of the TDNS PBC.
Noise Improvements	Strategic	Secondary order benefit which is difficult to quantify to include economically but the benefit would be realised.
Job Creation and Levelling Up	Strategic	Secondary order benefit which is difficult to quantify to include economically but the benefit would be realised.

Benefit	Case	Rationale
Rail technology deployment learning	Strategic	Secondary order benefit which is difficult to quantify to include economically but the benefit would be realised.

APPENDIX 6 – TRACTION TYPES TECHNICAL SUMMARY

DIESEL-MECHANICAL TRAINS

Diesel-mechanical trains operate using mechanical traction systems which comprise a fuel tank, internal combustion engine, cooling equipment, mechanical (or fluid-based) gearbox and transmission, and a small alternator for auxiliaries as seen below. Such trains are suited for lower speed applications (type A and B), with most mechanical trains achieving a top speed of 100 mph.

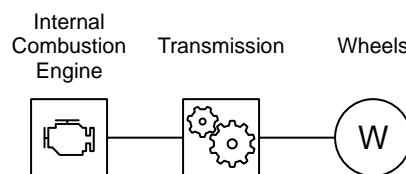

The engine creates mechanical torque which is transferred by the transmission to the wheels. In response to a power demand by the driver, the engine power is controlled, and the transfer ratio of the transmission adjusts to provide appropriate torque at the wheels, taking into account the train speed.

In mechanical multiple units, power is usually transferred between the engine, transmission and wheels via shafts, meaning such equipment must be in the same place, usually beneath the vehicle. Power transfer by pumping oil through pipes (hydrostatic) allows the engine and transmission to be located elsewhere underneath, and this is used on some on track machines. Each vehicle in a multiple unit set will typically have identical equipment with no trailer vehicles.

DIESEL-ELECTRICAL TRAINS

Most modern diesel trains have electric traction systems comprising a fuel tank, internal combustion engine, cooling equipment, generator, rectifier, traction converter and rotating machines. They are effectively an electric train with an onboard generator as summarised below.

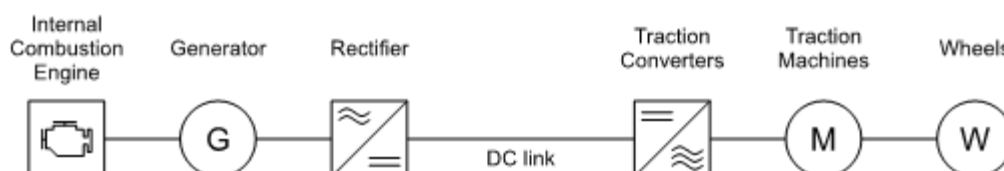

The engine creates mechanical torque which the generator converts to electrical power. This is rectified to DC, and the traction converter uses this power to drive the

rotating machine. In response to a power demand by the driver, the traction converter applies power to the rotating machine and the engine power adjusts automatically.

This architecture is common in locomotives and higher power multiple unit (type C) and can form part of a bi-mode solution where the electrical power generated can alternatively be sourced from a contact system (see traction combinations with diesel below).

The use of electric cabling gives flexibility for the location of equipment. It is still common for multiple units to have all the equipment beneath the train, however equipment has been located inside in some cases.

UK rail operations has multiple units and locomotives capable of 125 mph. High speed passenger trains typically require nightly refuelling, whereas a medium speed passenger train may complete more days between fuelling.

DIESEL TRAIN SUMMARY

There are several advantages with both diesel-mechanical and diesel-electric traction:

- diesel trains fully function without electrification and have go-anywhere capability;
- diesel is an energy dense fuel which is simple to store and distribute; and
- diesels trains cover long distances and sustain the highest speeds the classic rail network currently permits (125 mph)

There are several disadvantages with both also:

- all diesel trains with no exhaust treatment have a negative impact on air quality. New diesels have improved emissions, but this isn't guaranteed to bring air quality under control in covered stations without the use of ventilation;
- diesel multiple units are heavier than the electric equivalent;
- diesel trains generally have less power than electric trains; and
- diesel engines create additional noise and vibration.

Diesel engines need cooling equipment which can take up space. This is particularly noticeable in locomotives. Electric locomotives, with recent examples being around 4 MW, consistently out-perform diesels, with the most powerful examples reaching 2.5 MW.

DIESEL HYBRID AND MULTI-MODE TRAINS

Diesel-electric trains are well suited to hybridisation and can accept batteries, as shown below, to form a series architecture. The battery can recover braking energy, power auxiliaries and can propel the train for some distance thus allowing the engines to be shut

down when not needed. This can reduce and potentially eliminate diesel running in sensitive areas. The engines and batteries can also work together to boost power over limited distances to increase acceleration.

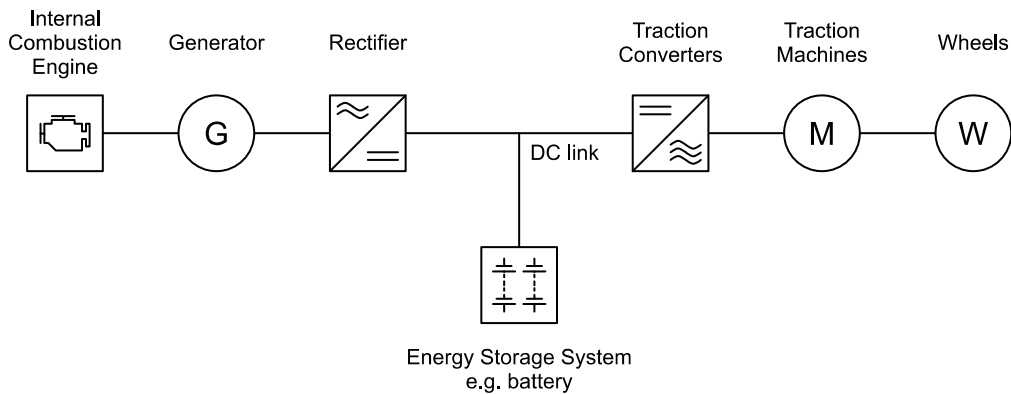

Diesel-mechanical trains can also be fitted with a recovery device and energy storage equipment to form a parallel hybrid as seen below. Solutions with electric rotating machines and batteries are commercially available, and other solutions such as hydraulic accumulators and flywheels are also possible.

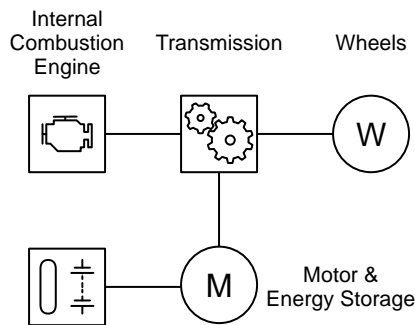

Hybridisation involves the addition of energy storage and conversion equipment, so is typically expected to increase the weight of a multiple unit vehicle depending on design. The main advantages are an expected fuel saving of around 20%, although this is heavily influenced by the driving cycle.

Hybrid trains can contribute significantly to air quality by shutting down all engines in stations. Some modern diesel-electrics have a similar function called selective engine shutdown where only the minimum number of engines are running at any time. Short of hybridisation, this can also reduce emissions in stations.

ELECTRIC TRACTION

There are two aspects to consider for electric traction: rolling stock and traction infrastructure. These two aspects are summarised below.

ELECTRIC TRACTION - ROLLING STOCK

Electric rolling stock takes the form of locomotives and multiple units, which share the common characteristic of taking electrical power from a continuous contact system and converting and controlling it to produce tractive effort. Locomotives will have all wheels driven, whereas the proportion and distribution of motored wheels on multiple units varies.

The specific methods of controlling power and rotating machine types have changed as technology has advanced. However, the high-level system layout of electric trains has remained broadly unchanged. The UK network makes use of three different power systems, each with their own contact system:

- 750 V DC via top contact conductor rail, also known as third rail;
- 25 kV AC via Overhead Line Equipment (OLE), also known as Overhead Contact System (OCS); and
- DC Overhead Line.

The system layout of a DC train is shown below. The contact system provides a DC supply via contact shoes directly to the traction converters to power the rotating machines and auxiliary converts to power other equipment on the train. Various other on-board components and systems, such as compressors, the train management system, circuit breakers and line filters are not included for brevity.

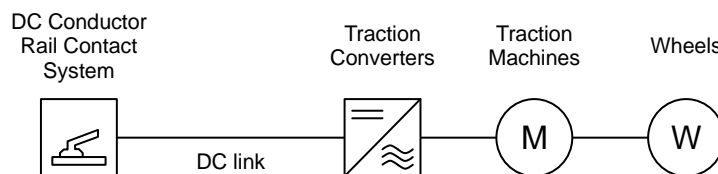

The system layout of an AC train can be seen below. The contact system provides an AC supply via a pantograph. A transformer then lowers the voltage, and a line converter converts the AC to DC to supply the traction converters via the DC link.

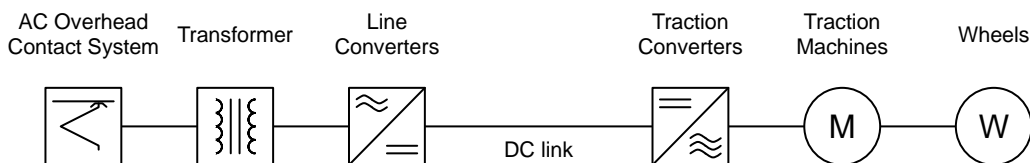

The AC train is effectively a DC train with extra equipment on-board to convert the AC energy to DC. This avoids the extra equipment being installed in fixed lineside locations.

Equipment, in the case of a multiple unit, is usually mounted to the underside of the train. Recent low-floor trains have seen some traction equipment mounted within the bodysell

of train and on the continent, and on trams in general, equipment is usually mounted on the roof for the same reason.

Electric trains powered by a contact system have the following advantages.

- Energy is not limited by a requirement to carry a finite amount of fuel.
- As no energy storage equipment needs to be carried, mass compared with other trains types is lower, which is advantageous to multiple units.
- Electric systems can be subject to short term overload to improve acceleration performance as the performance ceiling is usually limited predominantly by excess heat alone (especially when compared with onboard internal combustion engines).
- Under braking, energy can be regenerated and returned to the distribution network for use elsewhere, such as other trains.

In summary, if supplied with adequate infrastructure, electric trains can accelerate harder and travel faster than trains which carry energy onboard.

Electric trains powered by a contact system have the following disadvantages.

- Contact systems and power distribution networks are required the full length of the route where the train is expected to fully function.
- The electrification system must have the capacity to support all the trains using it, or the performance of the train must be moderated.
- The power distribution systems are reliant on the national grid to be effective with failure potentially leading to a major operational event.

In summary, traditional electric trains require dedicated infrastructure, in the form of a contact system and power distribution network, along the full length of the route intended for their travel.

ELECTRIC TRACTION - INFRASTRUCTURE

Electric trains need a sliding contact system, which supplies electrical energy from the distribution network to the train. Such contact systems are notionally continuous, however small gaps exist for the purpose of sectioning, grid connection, and to accommodate other infrastructure features.

As noted above, the UK uses three contact systems which operate at different voltages:

- 25 kV 50Hz AC via Overhead Line Equipment (OLE), also known as Overhead Contact System (OCS);
- 750 V DC via top contact conductor rail, also known as third rail; and
- DC Overhead Line Equipment.

Various factors have influenced the choice of contact system such as economics, technology, deployment capability and management decisions. However, with both systems, the power flows through the same major components, only with them located in different places.

In the early years of electric railways, the equipment needed to rectify AC to DC did not lend itself to being mounted on trains. In addition, reliably powering large rotating machines with AC also had challenges, leading to the widespread adoption of DC machines, until the power electronics able to power AC machines from a DC supply became practicable.

The diagram below summarises the end to end path of the energy used to power the train, and it can be seen the main difference between the AC and DC systems is the location of the second transformer and rectifier.

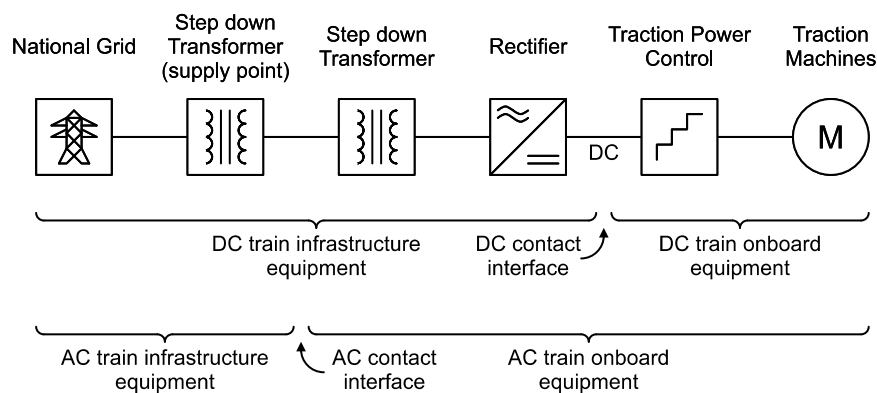

Voltages such as the 400, 275 and 132 kV supplies used by the National Grid are useful for minimising losses for long distance power distribution as this allows a reduced current, but supporting equipment, such as switchgear is large and expensive, so voltages such as 50 and 25 kV AC are used for the railway's AC contact system, and 33, 22 and 11 kV AC for DC third rail systems. This is still much too high for rotating machines, which are best powered in the 100s to low 1000s V, so the voltages mentioned are transformed down further and rectified to DC, in the case of third rail to 750 V DC. AC trains may use a higher voltage for the DC link, but 750 V may be picked to allow the design to be more compatible with the southern network. Finally, a traction converter converts the power into that suitable to power the machine.

25KV OVERHEAD LINE ELECTRIFICATION

This is the solution of choice for new railways across Europe and beyond in regions where the solution is not dictated by the presence of another system. The high voltage makes it an electrically efficient means of powering trains.

The power is provided to the train via a roof-mounted pantograph which slides along the contact wire which is connected to the distribution system. The contact wire is suspended

from a catenary cable which is supported by a series of lineside structures, such as cantilevers. The current goes through the train's onboard transformer and is returned via the wheels to the running rail, which is also connected to the distribution system.

The power distribution system will typically include feeder stations with neutral sections, and sectioning locations. The connection to the National Grid is known as a grid supply point. The system is designed with redundancy to allow continued operation in the event of a supply point failing.

Depending on the power requirements one of two power distribution methods may be installed:

- boosterless classic; and
- autotransformer

Boosterless classic is the simplest method. The contact wire and return conductor are connected to a transformer which is connected to a 132 kV grid supply point as seen below. A classic section can be a maximum length of around 30-40 km depending on load. This method only uses one or two of the three grid phases causing an imbalance. If the imbalance condition cannot be accepted on the 132kV connection, or if only 33kV is available at the location of the feeder station, a static frequency converter can facilitate a grid connection by allowing all three phases to be utilised.

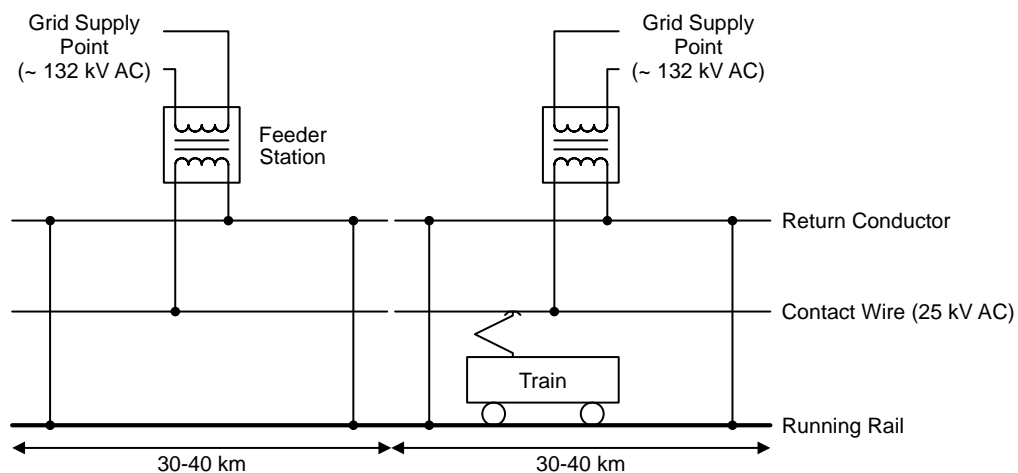

Autotransformers, seen overleaf, allow additional power to be distributed using an auxiliary conductor, which allows power to be effectively distributed at twice the voltage with the current being shared amongst autotransformers along the route; this typically allows for sections twice the normal size. Such systems are typically fed using the National Grid's 275 kV and 400 kV connections.

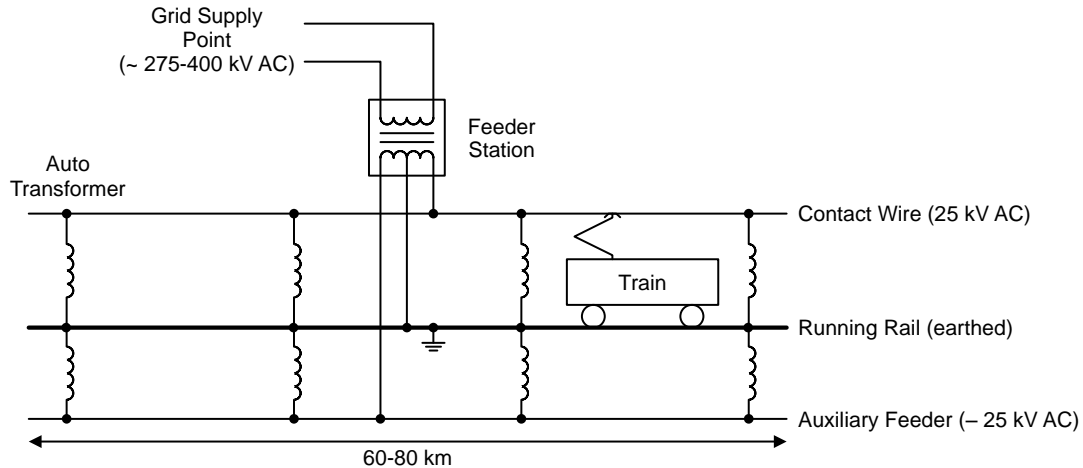

Installing overhead line does present some challenges to the UK network:

- bridges and tunnels require either rebuilding to a larger profile, lifting, or the track lowered; or specific limited clearance design solutions must be devised to accommodate the wires; and
- access to the railway is required over a long period of time to construct the contact system

750V DC THIRD RAIL ELECTRIFICATION

Distribution of energy at a low DC voltage such as this allowed the simplification of rolling stock, preventing the need for an on-board transformer and rectifier whilst still allowing simple control of the traction motors.

Electricity is distributed in a cable network alongside the railway to lineside substations. Due to the low third rail voltage, lineside substations must be close to each other, typically every two to five kilometres.

The lineside substations convert the voltage to 750 V DC. From the substations, the DC current is connected to a third rail, and the trains are fitted with shoes which slide on this to collect the current. The current is returned to the substations via the wheels and the rails. A simplified example is shown overleaf.

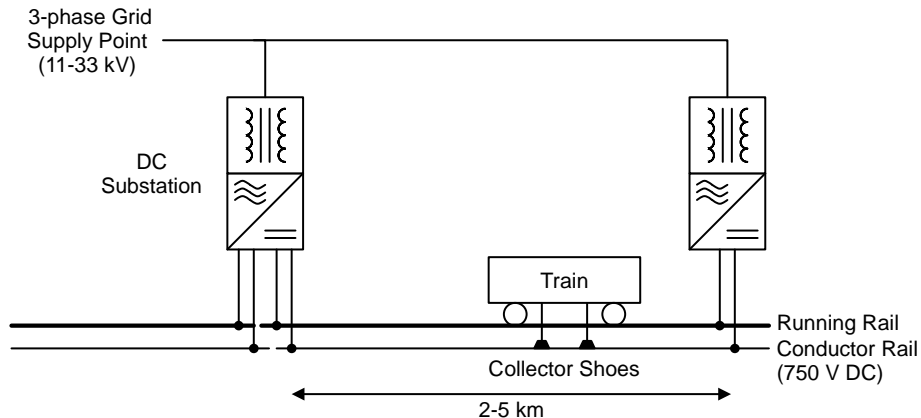

The most significant challenge to installing more third rail is the policy held by the ORR which requires all installations to comply with all applicable health and safety legislation. With such legislation in mind, such as the Electricity at Work Act, installing further third rail has been limited. A workstream jointly led by Network Rail, RSSB and ORR is exploring the opportunity to provide new infill third rail electrification where this is deemed feasible and appropriate.

BATTERY POWERED TRACTION

There are two aspects to consider for battery powered traction: rolling stock and traction infrastructure. These two aspects are summarised below.

BATTERY POWERED TRACTION – ROLLING STOCK

Battery-powered trains are electric multiple units and locomotives which carry batteries in order to provide traction power for in-service use.

All trains carry some form of battery. This is to start the on-board systems or connect to the infrastructure to start primary energy sources e.g. engines or raise the pantograph. They also supply lighting and ventilation for a limited time during primary power failure. Some modern multiple units are sometimes able to make low speed moves around depots on such batteries.

The traction system of a battery powered train is based on that of an electric train but with the addition of on-board battery storage and supporting power converters and temperature management for the battery if required.

A notable advantage of battery powered trains is the ability to integrate the technology into a conventional electric train and allow it to recharge from existing infrastructure and/or from discrete or discontinuous contact systems. The diagram overleaf shows how a battery may be integrated into the DC-link of an AC electric train. Here, the battery can be charged whilst on the move or from a stationary location. Integration into a DC trains is also possible.

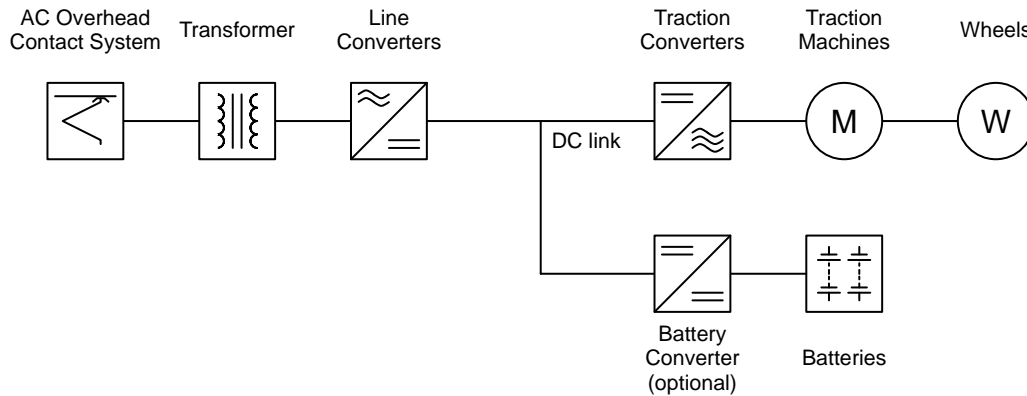

The performance characteristics of battery powered trains are limited in some areas, such as range and top speed. Although it is possible to continue to fit more and more batteries to increase performance, the economic benefit diminishes as the weight of on-board batteries and control systems increases relative to the capacity of the train. The market conditions on the continent in 2019 suggest the following performance characteristics:

- a range of 60-80 km. This depends on battery size, weight, average speed, terrain, stops and auxiliary requirements, operational reserve requirements and demanded battery warranty;
- realistic top speed of approximately 75 – 100 mph;
- fifteen minutes to fully charge;
- increased mass compared to an electric train; and
- auxiliary power e.g. heating and air conditioning, may need to be managed when on battery power to meet range requirements

Longer trains tend to allow more space for batteries, allowing for a longer range.

Lithium batteries tend to lose capacity with use and over time in general. Eighty percent of the plated capacity is a commonly used figure as an end of first life point. The rail industry aspired to a battery lifetime of at least five to ten years and the market seems confident in delivering this. To support a long lifetime and accommodate ageing loss, operation is restricted typically to the central fifty to sixty percent of the battery. Thermal management systems are also employed to maintain the battery at a temperature to maximise lifetime.

Charging on the move can make use of existing electrification systems i.e. 25 kV OLE and 750 V third rail, assuming the infrastructure has the capacity. Stationary charging can also use these methods, but other, potentially cheaper and/or faster systems may also be employed using systems specifically designed for the task.

Batteries have flexibility when it comes to their location. Connections are limited to electrical, data and pipework associated with temperature management. Assuming fire

safety requirements can be met, batteries may be mounted underneath, inside or on the roof of any vehicle in the train.

Battery trains have the following advantages.

- They can travel on parts of the network without a contact system.
- They can recharge on the move from existing contact system which under some circumstances can negate the need for additional infrastructure.
- Require only electricity to recharge.
- Quiet and produce no pollutants at the point of use.
- Batteries can be near seamlessly integrated into existing electric trains.
- They can bring additional benefit to a contact system in the form of peak load reduction and advanced rescue capability under power outage.

Battery trains have the following disadvantages:

- The cost and weight of batteries leads to an energy storage limit when it comes to economics and practicability.
- The energy storage limit leads to a range limit, and this range is traded for average speed and auxiliary load.
- Top speed is practically limited when compared to electric traction.

In summary, battery trains allow the introduction of emission-free trains on routes where the performance requirements do not exceed those of the trains. There is a potential requirement for electric charging infrastructure to facilitate this.

BATTERY POWERED TRACTION - INFRASTRUCTURE

Battery-powered trains require frequent connection to an electrical supply in order to recharge the on-board batteries. If the train operates on a contact system as an electric train, it is possible for the train to charge whilst on the move. If the battery can be charged sufficiently whilst on the contact system, it may be possible to introduce a battery-powered service with no additional infrastructure on the network.

If charging is required at a location away from a continuous contact system, a discrete charging facility may be required.

Network Rail currently has no preference regarding the specific design of the charging facility and there are various methods available.

- Short section of 25kV OLE and traditional pantographs – a good solution if the train has 25kV already fitted.
- A sliding or deployable DC connection either above or below the train.
- A plug and socket connection.
- Induction.

Safety requirements, such as protection from electric shock under the Electricity at Work Act, are well known to the industry. Depending on the design, required levels of safety may be met using passive design and/or detection and control systems, various concepts can be seen below.

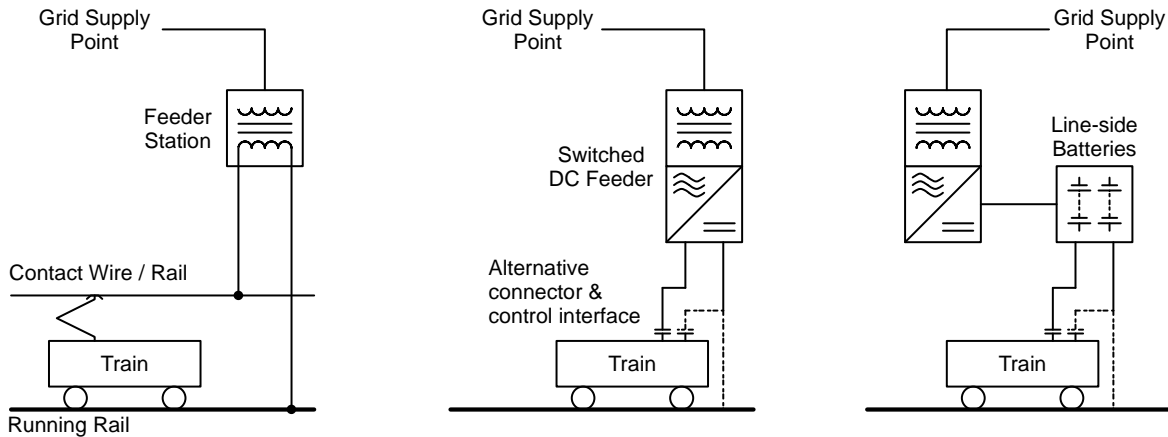

The static charging facility needs a connection to the National Grid. The size of the supply needed will depend on the charging power required and the amount of trains being charged at any one time. Likely static charge power can range from hundreds of kilo Watts to several Mega Watts; therefore, dedicated grid connections can be smaller than those for continuous contact systems.

Where the connection to the National Grid is weak, slower-charged lineside storage batteries capable of quickly transferring energy to the train can be considered.

The reliable changeover from contact system to contact system free running needs managing in some scenarios. Trains using third rail can passively transfer on to and off the contact system. Trains using OLE must raise or lower the pantograph only whilst under the OLE to prevent damage. This can be managed manually through signage and driver training where a station stop is conveniently located; however, changeover on the move, particularly at higher speeds, may benefit from automatic assistance.

As part of the change from diesel traction (particularly mechanical) to any electrical system, a compatibility assessment must be undertaken to determine if the train detection system requires immunisation or replacement.

HYDROGEN POWERED TRACTION

There are two aspects to consider for hydrogen powered traction: rolling stock and traction infrastructure. These two aspects are summarised below.

HYDROGEN TRACTION – ROLLING STOCK

Hydrogen-powered trains are electric multiple units which carry hydrogen, fuel cells, and batteries in order to provide traction power. There are other devices for the conversion of hydrogen to mechanical energy, such as internal combustion engines, and turbine solutions, but fuel cells are currently the most common.

There are various methods of storing hydrogen, but the method most prevalent in public transport is high pressure composite cylinders storing hydrogen at up to 350 bar. The cylinders are connected through pressure relief devices and pressure control devices to the fuel cells along with a supply of clean air. A cooling system maintains the temperature of the fuel cells.

The fuel cell facilitates an electrochemical reaction between the hydrogen and oxygen in order to produce electrical energy, waste heat, and water. Other than a cooling system, they have no significant moving parts, meaning they are quiet. The electrical energy is used to power the traction system and auxiliaries, and usually works in a hybrid configuration with a traction battery. The battery assists during heavy demand, captures energy from braking, and accepts energy from the fuel cell where appropriate to maintain system efficiency. A system layout can be seen below.

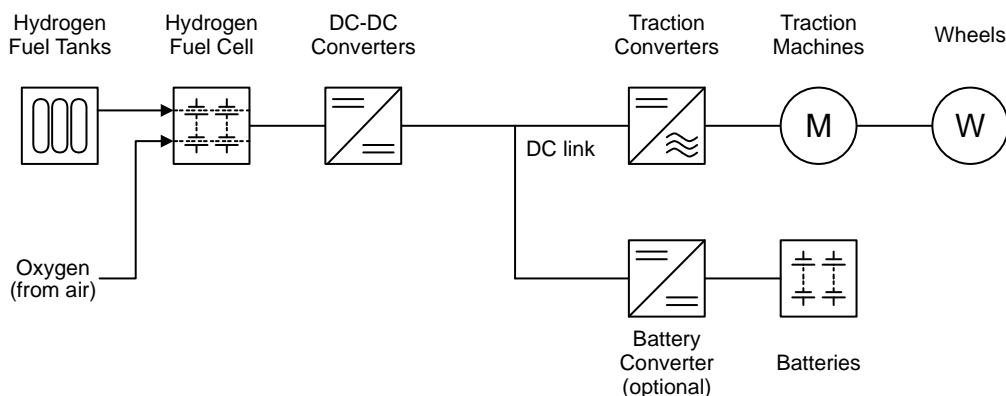

The market in 2019 suggests hydrogen-powered trains will have the following capability:

- a predicted range of around 1000 km. This depends on tank size, weight, average speed, terrain, stops and auxiliary requirements and operational reserve requirements;
- economic top speed of approximately 90 - 100 mph; and
- fifteen minutes refuelling time.

The hydrogen cylinders, fuel cells, cooling equipment and battery are flexible in where they can be located e.g. beneath, inside or on top of the vehicles, as the connections between them carry electrical energy and fluid. However, for a specified range, hydrogen storage consumes around eight times the space of diesel using 350 bar storage equipment;

therefore compromises in range, design or saloon space may need to be considered. 700 bar storage is also possible if stronger components are used, providing additional range at greater cost.

Refuelling of a hydrogen-powered train takes place in a refuelling facility via the connection of a specifically designed coupling. Hydrogen is either produced on or delivered to site. Refuelling is expected to take around fifteen minutes.

Hydrogen gas can pose a significant hazard if it leaks or escapes, particularly in a confined space. It is an odourless, invisible, lightweight gas which rises on escape. If allowed to accumulate in a confined space, such as the under the roof of a building, the atmosphere can become flammable or explosive under a wide variety of concentrations. High pressure released may also lead to combustion.

Risk controls such as component and system standards, leak detection, train and building design, and operational arrangements have been considered enough to allow public service on the continent.

Hydrogen-powered trains have the following advantages:

- they can travel on parts of the network without a contact system;
- there are quiet and produce no pollutants at point of use; and
- can be configured as a bi-mode to be powered by a contact system

Hydrogen-powered trains have the following disadvantages:

- for a specified range, hydrogen storage consumes around eight times the space of diesel using 350 bar storage equipment. Long range application may lead to reduced saloon space;
- so far, no hydrogen powered trains for freight or capable of 125 mph have been announced; 145 km/h (90 mph) is the current maximum being made available;
- fleet deployment currently also requires a source of suitable hydrogen to be identified or constructed; and
- the efficiency of electrolysis, compression and the fuel cell combined lead to energy consumption around three times that of conventional electric trains.

In summary, hydrogen trains are capable delivering relatively long-distance services at speeds competitive with mid power diesel multiple units with no emissions at point of use. The carbon intensity is dictated by the footprint of the method used to produce the hydrogen. Hydrogen trains requires little change to the mainline infrastructure; however, they require new fuelling systems (and potentially hydrogen production systems) to be constructed.

HYDROGEN TRACTION - INFRASTRUCTURE

Hydrogen-powered trains need to be regularly refuelled with compressed hydrogen gas. Whilst operation-specific, it is expected trains would need to be refuelled roughly once every twenty-four hours, such as during overnight stabling.

An example system layout of a fuelling system is shown below. The hydrogen is stored in bulk in a low or medium pressure vessel. A compressor then transfers the hydrogen to high pressure vessels which are used to refuel trains with a flexible hose. The image shows the Coradia iLINT (used in Germany) undergoing refuelling with a commercially available connector used for large vehicles. The hydrogen can be delivered to the refuelling site via road, rail or pipeline; or produced on site using an electrolyser, which would produce hydrogen from water using electricity, and would need a strong connection to the National Grid (and water supply).

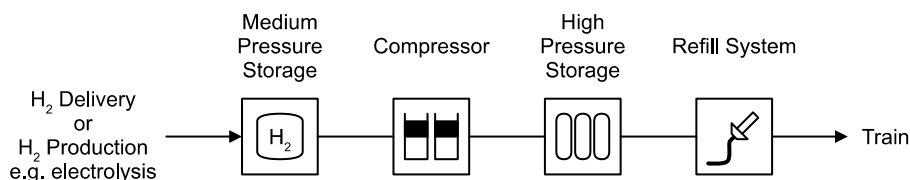

A typical compressed hydrogen road tank holds around 1,100 kg of fuel; liquid storage tanks hold around 3,500kg. Over 600 km the iLINT train in German was estimated to consume around 138 kg of hydrogen. This increases to 2,000 kg per day for 14 trains.

The carbon cost of hydrogen depends on how it is produced. Most hydrogen, produced for industrial purposes rather than as fuel, is produced by splitting methane gas into hydrogen and carbon dioxide; this has a relatively high carbon content and therefore does not contribute to decarbonisation unless the carbon is captured.

Hydrogen can also be sourced as an industrial by-product e.g. from chlorine production, and then cleaned, where it may otherwise be released to atmosphere, at a potentially lower

carbon cost. The carbon content of electrolysed hydrogen depends on the source of electricity with renewably generated sources being the preference.

The deployment of a hydrogen powered fleet would need the procurement of onsite storage and refuelling equipment and either electrolyzers or a hydrogen supply of sufficient size and reliability. The refuelling sites would be subject to hydrogen related standards and legislation, already mature in the automotive sector, and Network Rail needs to have knowledge of safe management of the plant.

APPENDIX 7 – EMBODIED CARBON AND ETHICS

This appendix outlines the considerations around embodied carbon and ethics for each of the three traction technologies.

BATTERY

Whilst the embodied carbon of battery infrastructure is likely to be less compared with hydrogen and electrification, due to the reduced amount of infrastructure needed, batteries themselves will have a significant embodied carbon value.

Batteries are typically composed of chemical mixtures using natural minerals found around the world. The vast majority of these minerals are found in Africa, South America and Asia. The extraction of these minerals through mining can often be very labour-intensive and requires significant amounts of heavy machinery. Once extracted, the minerals then need to be combined through high energy processes to manufacture batteries, with these often-requiring minerals to be shipped internationally. Once batteries are completed, they are then further shipped to suppliers for use. As a result of the significant energy consumption required during mineral extraction, transportation and manufacturing it has been suggested that up to 27% of the life-cycle GHG emissions (g/km) come from the manufacture of some batteries¹⁴⁷

Proposals have been identified to reuse traction batteries as line-side energy storage batteries once they are unsuitable for rolling stock operations. This could potentially prolong the embodied carbon impacts associated with them.

Furthermore, recycling and disposal of batteries are complex and there are limited organisations which can offer this currently. The disposal of batteries requires extensive high energy processes. Given that battery life can range from five to fifteen years both the manufacture and disposal processes occur several times over compared with electrification infrastructure which is renewed on a thirty to fifty-year time horizon. This means the embodied carbon associated batteries has to be accounted for several times over in the same timescales associated with infrastructure.

ELECTRIFICATION

Electrification requires significant volumes of infrastructure which mostly uses steel, copper and concrete. All three of these materials have embodied carbon and the significant quantities required will undoubtedly mean that electrification infrastructure has a major

¹⁴⁷ International Council of Clean Transportation, 2018, Effects of Battery Manufacturing on electric vehicle lifecycle greenhouse gas emissions p. 5.

carbon footprint. Realising embodied carbon efficiency and material recycling is a key focus of the Considering Carbon in Investment workstream of the Decarbonisation Programme.

Railway infrastructure embodied carbon has been progressively more understood over the past ten years through the adoption of the Rail Carbon Tool¹⁴⁸. This is now mandated for all infrastructure enhancement projects in Network Rail and is becoming more frequently used to drive down volumes of embodied carbon in infrastructure projects.

One project workstream within the wider Decarbonisation Programme is looking at how to reduce embodied carbon within infrastructure through the use of smarter materials and installation techniques.

A sample single track kilometre of electrification was generated within the RSSB Rail Carbon Tool and suggested that the embodied carbon per route kilometre could be on average around 680 tonnes of CO₂.

HYDROGEN

Hydrogen trains require batteries to store residual energy and as a result the items outlined above for battery are equally as applicable to hydrogen.

In addition to battery provision, however, there is a significant amount of infrastructure required for hydrogen fuel storage. Due to the volatility of compressed hydrogen, the tanks in which it is stored are often big and dense. These require significant amounts of material which can have significant embodied carbon.

Depending on how hydrogen fuel is delivered the transportation can carry embodied emissions in the supply chain. This is especially true where fuel is moved by road rather than through a pipeline.

ETHICS

Similarly to embodied carbon this assessment does not provide a comprehensive overview or consideration of any ethical issues but provides a brief overview of the potential areas which require consideration.

As outlined in the previous section batteries require significant natural mineral extraction with this mostly occurring in Africa, South America and Asia. The volumes of minerals required are significant for battery production at scale and thus significant volumes of mining are required. With working practices in these continents typically not as stringent as those found in other parts of the world with cases of child labour and extensive working hours, the ethical nature of battery minerals could be questioned.

¹⁴⁸ RSSB, Railway Electrification Case Study.

APPENDIX 8 – TRACTION DECARBONISATION RECOMMENDATIONS REGIONAL BREAKDOWN

SINGLE TECHNOLOGY RECOMMENDATIONS

Both this section and the next section outline the national recommendations for decarbonisation technology deployment on the UK rail network.

The recommendations outlined below do not indicate a delivery prioritisation and represent the end-state position for traction decarbonisation. The recommendations included over these two sections are far reaching and will require a significant period of time to deliver. As such their delivery may extend beyond 2050 in order to optimise delivery efficiency and limit disruption to the rail network. In order to achieve zero emissions by 2050 there may be a need to deploy interim solutions for certain areas. This notion begins to be explored in the commentary provided alongside the recommendations but will need further consideration as the programme of decarbonisation emerges as part of the PBC.

The final recommendations made as part of the TDNS Programme Business Case will show maps in time increments to illustrate the programme of decarbonisation. This document only contains the national recommendations for the end state decarbonisation and no indication of when these recommendations will be implemented is provided at this stage. The maps presented are for an “end-state” network and are not indicative of the status of the network in a specific year.

This section outlines those areas with single option solutions and provides some supporting commentary identifying the impacts on passenger and freight operations.

The second section in this appendix outlines those areas with multiple options and provides some supporting commentary identifying the relative merits of the technologies which could be used alongside indications of the cost benefit analysis and a recommendation for which technology could be deployed where a clear recommendation can be made.

The maps shown over the coming pages outline the end-state decarbonisation recommendations. These are broken down by broad geographical regions.

In deploying the methodology outlined in section 5.7 there were a number of areas of the network which were only just within the parameters of “single option”.

For electrification these areas are identified on the maps as “ancillary” electrification. For the purpose of the analysis these routes have not been split out as the methodology identifies them for electrification. It was however felt prudent to identify these areas.

For battery and hydrogen where route length is on the fringe of the capability of the relevant technology this has been identified in the supporting commentary. The maps and commentary should be taken in conjunction with each other and considered together.

SCOTLAND (SCO)

The outputs for Scotland's Railway for TDNS have utilised the work done by Transport Scotland and Scotland's Railway Region in the creation of a rolling programme of electrification for Scotland.

Details of this work can be found in the Decarbonisation Action Plan. The figure below, extracted from the decarbonisation action plan, shows the proposed end state (2045) of the Scottish network. The rationale behind this and subsequent commentary is outlined in detail within the Decarbonisation Action Plan¹⁴⁹.

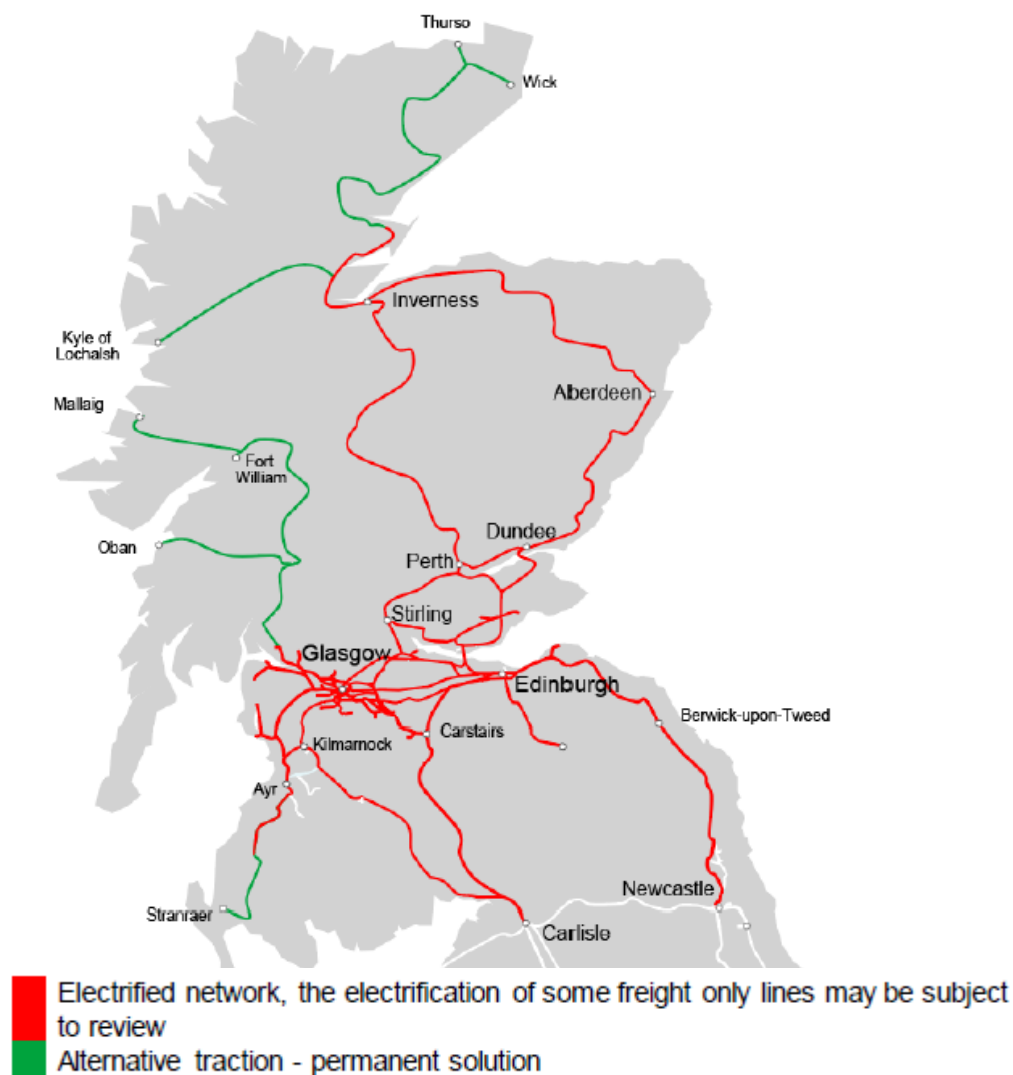

¹⁴⁹ Transport Scotland, 2020, Rail Services Decarbonisation Action Plan.

NORTH EAST, NORTH YORKSHIRE AND HUMBERSIDE (NENYH)

The following single option solution recommendations are made for the North East, North Yorkshire and Humberside. Commentary supporting the single option recommendations is provided in the table overleaf.

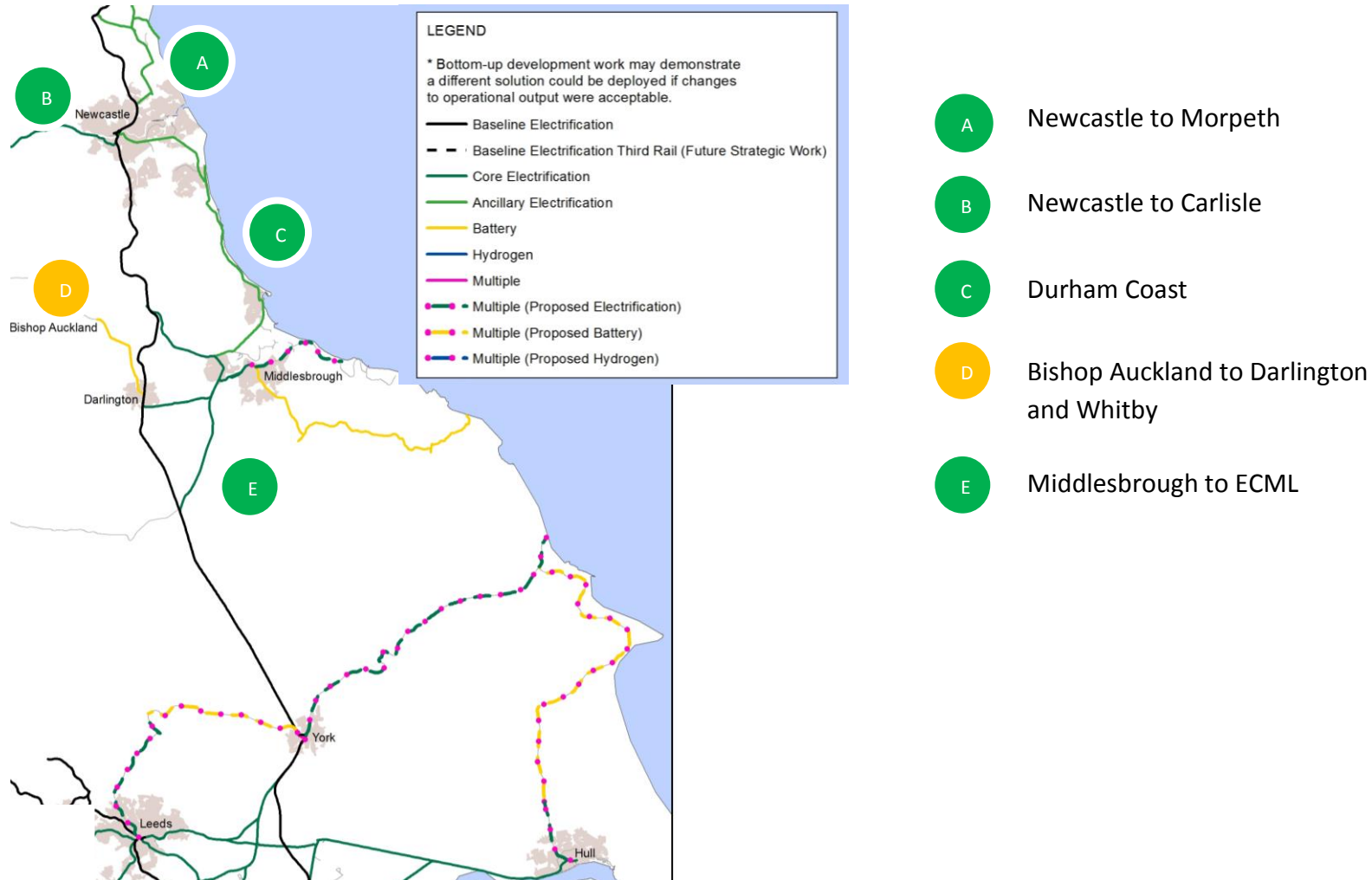

Segment	Technology	Commentary
NENYH A	Electrification	<p><u>Freight</u></p> <p>This is a freight only segment with a significant freight flows north of Newcastle accommodated to Morpeth serving destinations along the route and providing a route avoiding the ECML. There are plans to re-introduce passenger services on this route and extending this to Ashington.</p>
NENYH B	Electrification	<p><u>Passenger</u></p> <p>Regional passenger services between Newcastle and Carlisle operate providing an East-West link.</p> <p><u>Freight</u></p> <p>There are some cross-country freight flows using this route, with this being a route between ECML and WCML in the north of England. Due to the emerging Energy Coast Rail Upgrade project, there is scheduled to be an uplift in freight flows between Carlisle and Newcastle.</p>
NENYH C	Electrification	<p><u>Passenger</u></p> <p>Durham Coast provides a regional passenger service linking Middlesbrough to Sunderland and Newcastle. There are also long-distance high-speed services provided by Open Access Operator Grand Central between Sunderland and King's Cross. LNER services from Sunderland operate via Newcastle, but Durham coast in conjunction with segment NENYH E could provide an electrified diversionary route between Newcastle and Northallerton.</p> <p>A small section of this segment is electrified as 1,500V DC for use by Tyne and Wear Metro services. The infrastructure provided here is capable for use by 25kV feeds. Work is required to identify optimum traction feeding for services in this area given the new Tyne and Wear Metro rolling stock being procured by Nexus.</p>

		<p><u>Freight</u></p> <p>There are some freight services which operate from Teesside via the Durham Coast in order to avoid the ECML and to serve destinations along the route.</p>
NENYH D	Battery	<p><u>Passenger</u></p> <p>Regional passenger services operate from Bishop Auckland to Teesside and North Yorkshire. With the electrification of wider Middlesbrough area in conjunction with NENYH C and NENYH E it could be possible to achieve operations with recharging from this infrastructure. Without this infrastructure the deployment of hydrogen on either an interim or permanent basis would be more appropriate. The presence of the Hitachi rail depot at Heighington (Newton Aycliffe) may warrant electrification to this point.</p>
NENYH E	Electrification	<p><u>Passenger</u></p> <p>Regional passenger services between ECML and Middlesbrough and Durham Coast operate over these areas. Services originating from Bishop Auckland would require this section to be electrified if they are to be battery operated to provide recharging time for batteries. This route can also be used as a diversionary route for ECML services to access Darlington.</p> <p><u>Freight</u></p> <p>Linking Teesside to the ECML in both the northern and southern directions is critical for freight traffic from Teesport. There are major freight flows from Teesport into the Scottish belt and thus this will be critical to decarbonisation of freight in Scotland. There is an opportunity to provide electrification in conjunction with W12 gauge enhancement work which is currently being developed. The central of these three routes is currently the only high-gauge route to Middlesbrough, so its importance as a freight route will also depend on the extent to which other routes are cleared.</p>

EAST MIDLANDS, YORKSHIRE AND LICOLNSHIRE (EMYL)

The following single option solution recommendations are made for the East Midlands, Yorkshire and Lincolnshire. Commentary supporting the single option recommendations is provided in the table overleaf.

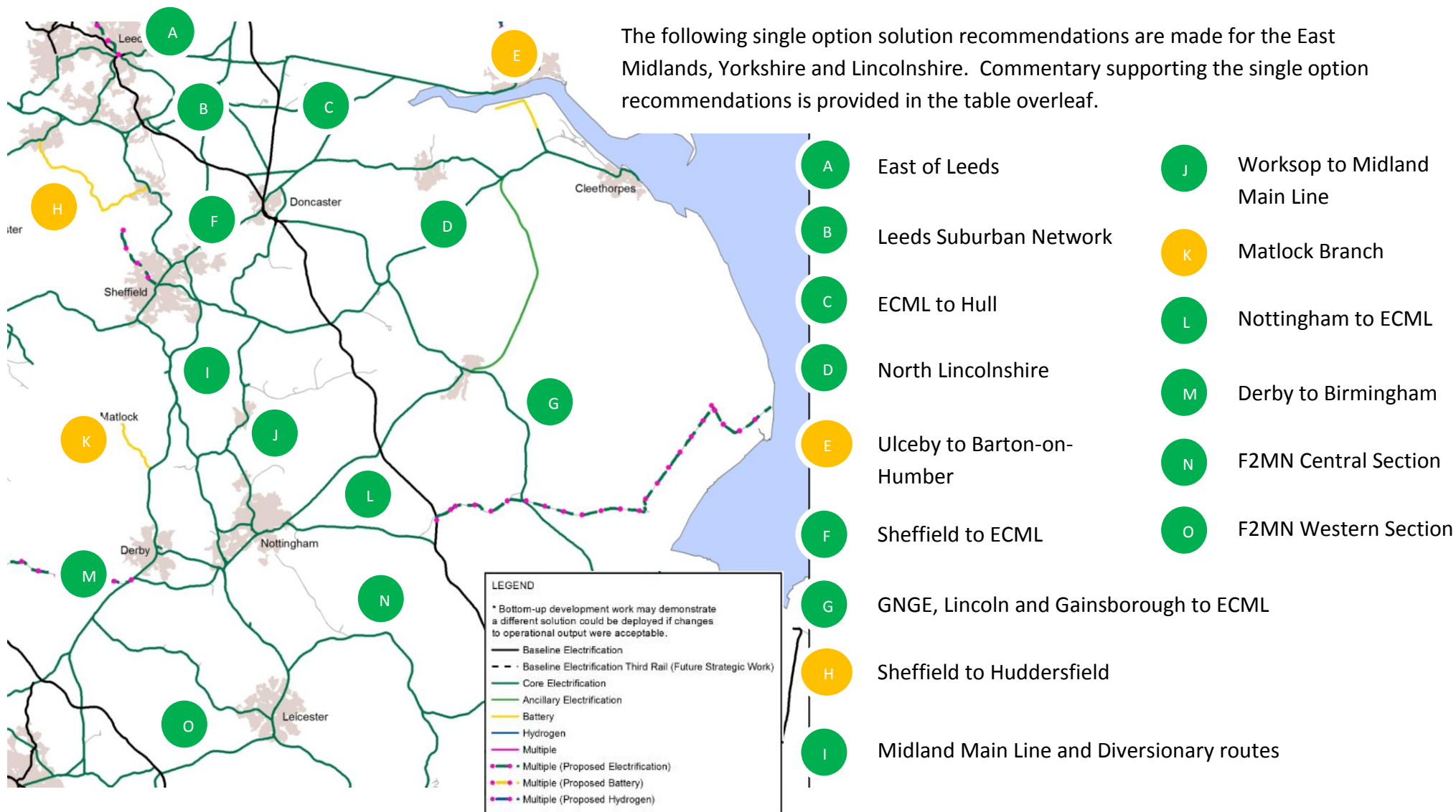

Segment	Technology	Commentary
EMYL A	Electrification	<p><u>Passenger</u></p> <p>Transpennine flows operate both long-distance high-speed services and regional services in this area. CrossCountry long-distance high-speed services also operate. Regional flows in the Leeds area are complex, with multiple junctions and routes available. The result is a high quantum of services with high speed differential and poor performance – the corridor would benefit from higher-performing and more resilient electric traction. The Transpennine route upgrade is currently being developed in this area and an opportunity exists to provide electrification in conjunction with this major programme.</p> <p><u>Freight</u></p> <p>Freight flows to and from the North East, North West and Transpennine areas towards the Midlands operate through this area as well as through EMYL B and EMYL F. Hunslet aggregates terminal forms a key destination for freight in the Leeds area.</p>
EMYL B	Electrification	<p><u>Passenger</u></p> <p>The complex nature of the wider Leeds Suburban network and its intensity of use makes this one of the most complex areas of the network outside of London. There are a number of stopping services with stations close together alongside long-distance high-speed services from Transpennine, CrossCountry and Grand Central. Provision of an electrical diversionary route from the ECML to Leeds would provide added resilience. This would equally provide a long-term solution to air quality and carbon emissions in the Leeds City Region, which is a key priority for local stakeholders.</p> <p><u>Freight</u></p> <p>As with passenger services there are a number of flows from the Midlands to the North East which operate through this area. There is notable freight growth envisaged on Transpennine routes and in the wider container and aggregate markets. There are a number of freight terminals in and around the wider Leeds area.</p>

EMYL C	Electrification	<p><u>Passenger</u></p> <p>Both LNER and First Hull Trains operate long-distance high-speed services which leave the ECML at Doncaster and travel onward to Hull. Additionally, Transpennine services operate from Selby to Hull in addition to the numerous regional services operated by Class 15x diesel units.</p> <p><u>Freight</u></p> <p>Flows from Hull to the ECML via both Selby and Goole.</p>
EMYL D	Electrification	<p><u>Passenger</u></p> <p>Local passenger services from Lincoln, Gainsborough and Doncaster towards Cleethorpes and Barnetby.</p> <p><u>Freight</u></p> <p>There are a number of freight services which operate from Immingham port toward the ECML and will require electrification of the Barton-on-Humber branch as far as Ulceby.</p>
EMYL E	Battery	<p><u>Passenger</u></p> <p>Short passenger branch line from Barton-on -Humber to Cleethorpes providing a local passenger service. Assuming electrification of rail to Cleethorpes and as far as Ulceby with charging facilities at Barton-on-Humber. Electrification beyond Ulceby to Barton-on-Humber could be considered as part of EMYL D.</p>
EMYL F	Electrification	<p><u>Passenger</u></p> <p>Long-distance high-speed CrossCountry services operate from Doncaster to Sheffield as well as providing the express link between Sheffield and Leeds. Stops are located in close succession to each other and the mixture of stopping, semi-fast and express services create performance issues across the corridor. This would also provide a strategic diversionary route for Leeds to London.</p>

		<p><u>Freight</u></p> <p>As outlined in EMYL A and EMYL B there are a number of freight flows from the North East and Yorkshire to the Midlands which operate through this area. Freight services from terminals in the wider West and South Yorkshire area also operate using these routes. The long-term prospect of coal flows to West Burton power station, given its upcoming closure, may affect the extent to which electrification is needed.</p>
EMYL G	Electrification	<p><u>Passenger</u></p> <p>The GNGE route and its links to the ECML are used by regional passenger services using Class 15x diesel rolling stock. They also provide a key diversionary route between Doncaster and Peterborough for ECML operators. Providing electrified resilience will allow these services to continue to operate during perturbation.</p> <p><u>Freight</u></p> <p>GNGE provides the major freight route from Peterborough to Doncaster as it offers a W12 gauge clear route. Services from Felixstowe to Doncaster operate on this route as well services from the wider Lincolnshire area to the ECML.</p>
EMYL H	Battery	<p><u>Passenger</u></p> <p>Local passenger service between Sheffield, Barnsley and Huddersfield.</p>
EMYL I	Electrification	<p><u>Passenger</u></p> <p>The Midland Mainline remains one of the few remaining unelectrified long-distance high-speed networks on the wider UK network. It is used by East Midlands services beyond Market Harborough onto Leicester, Nottingham, Derby, Sheffield and Leeds. CrossCountry services also operate between Sheffield and Derby. There are a number of regional services that are also operated using Class 15x diesel units. This will support HS2 services accessing Sheffield via the conventional network.</p>

		<p><u>Freight</u></p> <p>There are a number of major cross-country freight flows and flows to inland freight terminals in the Midlands. These services mostly originate from London, Southampton and Felixstowe. There are also a number of services operating through this area linking the West and South of England and Wales to the North East. A large number of construction and aggregates trains operate through this route, originating in the East Midlands and Peak District.</p>
EMYL J	Electrification	<p><u>Passenger</u></p> <p>Used by regional services between Nottingham, Worksop and Doncaster. This route may provide some diversionary use for the Midland Mainline.</p> <p><u>Freight</u></p> <p>This route is used by freight to access Rossington iPort.</p>
EMYL K	Battery	<p><u>Passenger</u></p> <p>Short passenger branch line from Matlock to Derby providing a local passenger service.</p>
EMYL L	Electrification	<p><u>Passenger</u></p> <p>East Midlands Trains operates a cross-country service from Norwich to Nottingham and Liverpool using this route. There are also a number of regional commuter services to the Midlands and Lincolnshire. These operate using Class 15x diesel rolling stock.</p> <p><u>Freight</u></p> <p>Services from Lincolnshire and the ECML towards the Midlands operate in this area.</p>
EMYL M	Electrification	<p><u>Passenger</u></p> <p>CrossCountry long-distance high-speed services operating from Scotland, the North East and Midlands use this link between Derby and Birmingham to access destinations in the West Midlands, South West and South coast.</p>

		<p><u>Freight</u></p> <p>Similarly, a significant volume of freight traffic from the North East and East Midlands uses this route to access locations in the West Midlands, South and West of England, South Wales and the WCML.</p>
EMYL N	Electrification	<p><u>Passenger</u></p> <p>Regional CrossCountry services operate between Leicester and Peterborough. This route also can act as a diversionary route for the Midland Mainline.</p> <p><u>Freight</u></p> <p>Major flows from Felixstowe port in East Anglia utilise this route to access the Midlands and the North West. There are also a number of construction material flows which use this route.</p>
EMYL O	Electrification	<p><u>Passenger</u></p> <p>Regional CrossCountry services operate between Leicester and Nuneaton.</p> <p><u>Freight</u></p> <p>Major flows from Felixstowe port in East Anglia utilise this route to access the Midlands and the North West as well as a link to the WCML. There are also a number of construction material flows which use this route.</p>

ANGLIA (ANG)

The following single option solution recommendations are made for Anglia. Commentary supporting the single option recommendations is provided in the table overleaf.

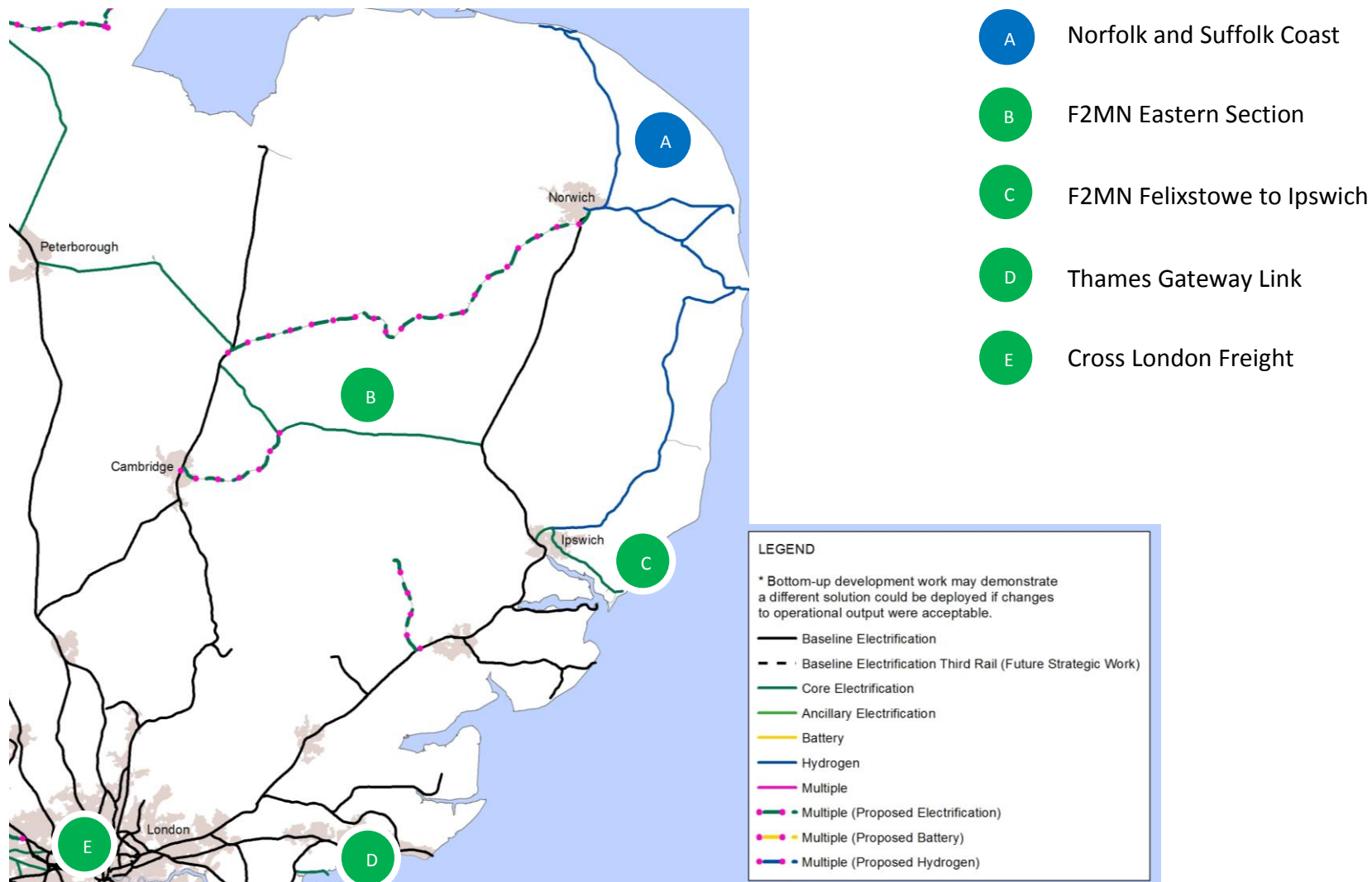

Segment	Technology	Commentary
Ang A	Hydrogen	<p><u>Passenger</u></p> <p>Passenger services radiate out of Norwich to Great Yarmouth, Lowestoft and the North Norfolk coast. There are also regional services from Lowestoft to Ipswich. The distances between Norwich and these areas are right on the edge of battery capability currently. The diagramming of this service would result in hydrogen being more appropriate. There is also a growing hydrogen economy in the Lowestoft area.</p> <p><u>Freight</u></p> <p>Some infrequent freight services operate in this area. These would require a bi-mode locomotive to be used which may incur residual diesel emissions if diesel is used as the bi-mode option.</p>
Ang B	Electrification	<p><u>Passenger</u></p> <p>This route supports regional services between Ipswich to Peterborough via Ely.</p> <p><u>Freight</u></p> <p>Major flows from Felixstowe port utilise this route to access the Midlands and the North West and North East. A number of construction materials flows also utilise this route.</p>
Ang C	Electrification	<p><u>Passenger</u></p> <p>Local passenger service from Felixstowe to Ipswich operate on this branch line.</p> <p><u>Freight</u></p> <p>Major flows from Felixstowe port utilise this route to access the Midlands and the North West as well as services using the Great Eastern Main Line. Construction materials flows also utilise this route.</p>

Ang D	Electrification	<p><u>Freight</u> Provides electrical connection from London Gateway Port to Essex Thameside route for container traffic.</p>
Ang E	Electrification	<p><u>Freight</u> The small unelectrified section between Gospel Oak and Kentish Town provides electrical access for cross-London freight from and to the Midland Main Line and WCML supporting construction material flows. The section between Acton and Cricklewood and Brent Curve Jn provides freight access from South and West London to the WCML, Chiltern Main Line and Midland Main Line.</p>

SOUTHERN (SOUTH)

The following single option solution recommendations are made for Southern. Commentary supporting the single option recommendations is provided in the table overleaf.



Basingstoke to Reading



South Coast to Salisbury



West of England Line

LEGEND

* Bottom-up development work may demonstrate a different solution could be deployed if changes to operational output were acceptable.

- Baseline Electrification
- - - Baseline Electrification Third Rail (Future Strategic Work)
- Core Electrification
- Ancillary Electrification
- Battery
- Hydrogen
- Multiple
- Multiple (Proposed Electrification)
- Multiple (Proposed Battery)
- Multiple (Proposed Hydrogen)

Segment	Technology	Commentary
South A	Electrification	<p><u>Passenger</u></p> <p>Services operate between Basingstoke and Reading on a frequent service interval. The services broadly expand onto the third rail network. CrossCountry long-distance high-speed services also operate from Reading to Southampton.</p> <p><u>Freight</u></p> <p>Southampton is one of the busiest container ports in the UK and sees a significant volume of freight traffic to the Midlands and North West. Provision of an alternative diversionary route via South C and South B is possible. Most traffic travels over the existing third rail network to Basingstoke. As freight is highly unlikely to be able to use third rail for tractive purposes locomotives using this route would require to be bi-mode, or the third rail between Southampton and Basingstoke replaced with a 25kV overhead line solution. If bi-mode locomotives were used this may incur residual diesel emissions if diesel is used as the bi-mode option.</p>
South B	Electrification	<p><u>Passenger</u></p> <p>Regional services operate along this route with passenger services between Exeter, Salisbury, Basingstoke and London Waterloo using Class 15x diesel units. This line is also used as a diversionary route for the Great Western Main Line.</p> <p><u>Freight</u></p> <p>The section between the Salisbury area and Worting Jn is used as a diversionary route for container traffic to and from Southampton. Some construction materials trains also use this section. There is no regular commercial freight west of Wilton Jn.</p>

South C	Electrification	<p><u>Passenger</u></p> <p>Regional services operate from Southampton to Salisbury. Acts as a diversionary route for long-distance high-speed CrossCountry operations from Southampton.</p> <p><u>Freight</u></p> <p>Diversionary route for freight services from Southampton to the midlands and North West. This section is also used by construction materials flows.</p>
----------------	-----------------	--------------------------------------------------------------------------------------------------------------------------------------------------------------------------------------------------------------------------------------------------------------------------------------------------------------------------------------------------------------------------------------------

Western and the South West (WSW)

The following single option solution recommendations are made for Western and the South West. Commentary supporting the single option recommendations is provided in the table overleaf.

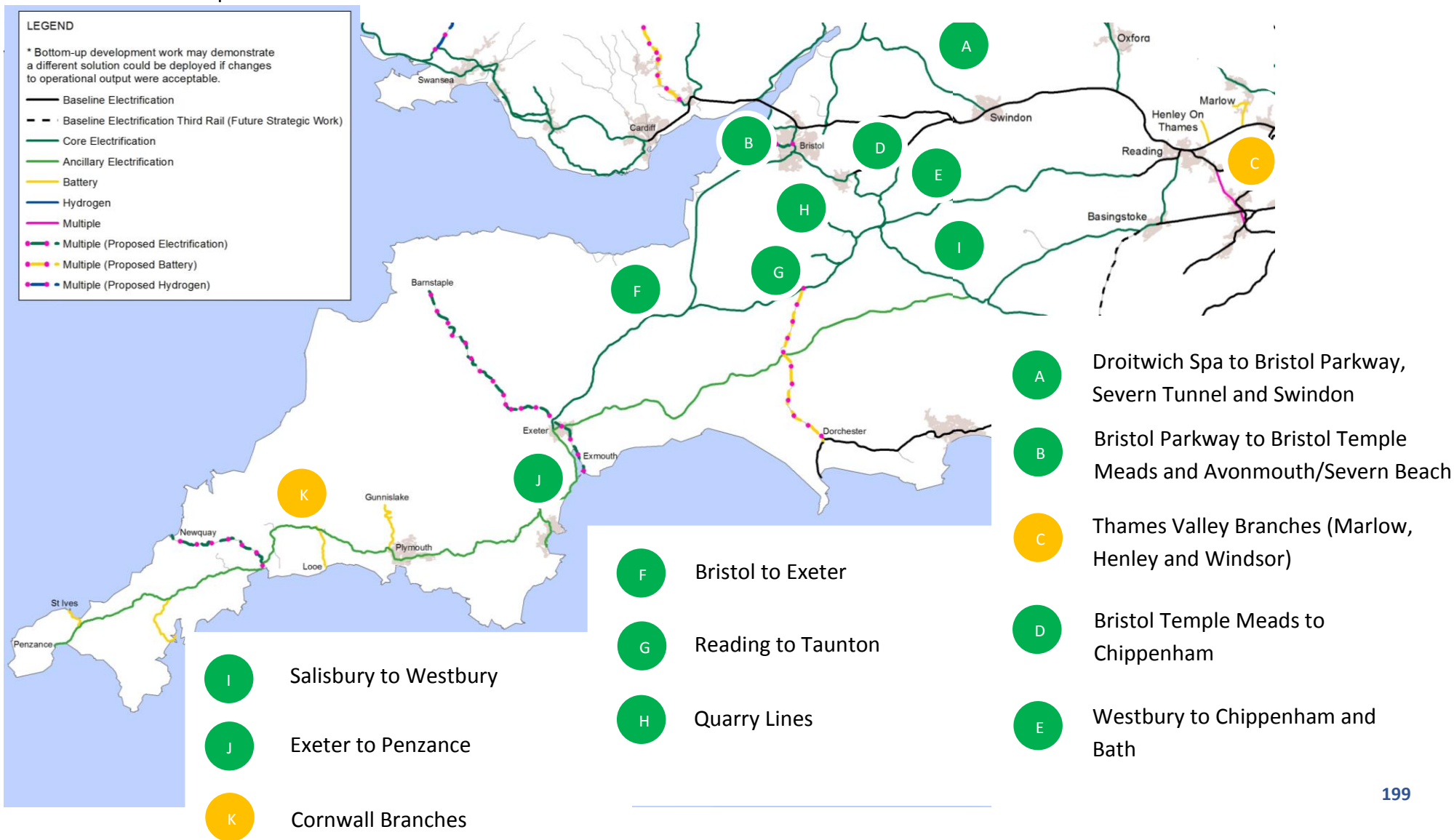

Segment	Technology	Commentary
WSW A	Electrification	<p><u>Passenger</u></p> <p>Long-distance high-speed CrossCountry services from the north via Birmingham to Bristol and the South West, and from the East Midlands via Birmingham to South Wales, operate over this route. There are inter-regional services from Cheltenham to both South Wales and Swindon (and London). There are also local services between Worcestershire, Gloucestershire, and Bristol.</p> <p><u>Freight</u></p> <p>Freight flows from South Wales destined for the Midlands and North East use this route as well as aggregate traffic from quarries in the Western region and intermodal traffic from South Wales.</p>
WSW B	Electrification	<p><u>Passenger</u></p> <p>The recently four-tracked route section between Bristol Temple Meads and Bristol Parkway is at the heart of rail services in the Greater Bristol area. Extension of electrification from Bristol Parkway to Bristol Temple Meads would enable Great Western Railway long-distance high-speed services between London and Bristol (via Bristol Parkway) to operate fully under electric traction. It would also allow long-distance high-speed CrossCountry services to operate electrically on this section. It could also allow inter-regional services between South Wales and Bristol to operate electrically. A number of regional and local passenger services also operate including routes between South Coast/Wiltshire & Gloucestershire; South Coast/Wiltshire & Cardiff; Taunton/Weston-super-Mare & Cardiff; and Weston-super-Mare & Filton Abbey Wood.</p> <p>The West of England Combined Authority is developing the Metrowest proposals which will entail significant service enhancements for Greater Bristol, many of which could exploit the future electrification of these routes, including introducing passenger services to the Henbury branch of the Severn Beach line.</p>

		<p><u>Freight</u></p> <p>Freight flows include aggregates, cement and occasional intermodal traffic to/from Avomouth; plus a terminal for waste-to-energy flows in the Severn Beach area. This means that there is significant freight traffic in this area accessing the Great Western Mainline.</p> <p>A new intermodal facility in the Avonmouth area remains a long-term aspiration of stakeholders and would benefit from electrification of these routes.</p>
WSW C	Battery	<p><u>Passenger</u></p> <p>There are a number of short branch lines which operate from the Great Western Mainline in the Thames valley area. These provide shuttle services to stations on the GWML. Due to the relative lengths of these routes it is recommended that battery application is deployed.</p>
WSW D	Electrification	<p><u>Passenger</u></p> <p>The majority of Great Western Railway long-distance high-speed services between London and Bristol operate via Chippenham and Bath. Electrification of this route would allow all these services to operate fully under electric traction. The section between Bristol and Bath is also used by local and regional services to Bath, south Wiltshire, and the South Coast.</p> <p><u>Freight</u></p> <p>Freight aggregates traffic joins the route at Thingley Junction. There are occasional freight services on the mainline. The section between Bathampton Jn and Bristol offers a diversionary route between the south coast and midlands and north.</p>
WSW E	Electrification	<p><u>Passenger</u></p> <p>As well as a regional commuter service this route also acts as a diversionary route for long-distance high-speed Great Western Railway services between London and the South West and Bristol.</p>

		<p>The West of England Combined Authority is developing the Metrowest proposals which will entail significant service enhancements for Greater Bristol, including Bristol-Bath-Westbury services which could exploit the future electrification of this route. Enhancements to the regional service are also proposed.</p> <p><u>Freight</u></p> <p>Aggregate traffic from the quarries (WSW H) can utilise this route to gain access to the Great Western mainline. These trains are some of the heaviest on the network. This route can also act as a diversionary route for freight traffic from Southampton destined for the West Midlands.</p>
WSW F	Electrification	<p><u>Passenger</u></p> <p>Extension of electrification to Bristol Temple Meads and beyond to the South West would enable CrossCountry and GWR long-distance high-speed services to operate electrically. Regional and local passenger services also operate including routes between Taunton/Weston-super-Mare & Cardiff; and Weston-super-Mare & Filton Abbey Wood.</p> <p><u>Freight</u></p> <p>Some freight flows to and from Devon and Cornwall also use this route.</p>
WSW G	Electrification	<p><u>Passenger</u></p> <p>Long-distance high-speed services operating between London and the South West utilise this route. There are a number of North-South regional services which utilise parts of this route and could therefore also benefit from electrification. This route also acts as an occasional and a diversionary route for Great Western Railway long-distance high-speed services between London and Bristol. The Night Riviera sleeper service between Cornwall and London Paddington also uses this route.</p> <p><u>Freight</u></p> <p>There are significant aggregates flows from the Quarry lines (WSW H) towards London and South East England. These trains are some of the heaviest on the network.</p>

WSW H	Electrification	<p><u>Freight</u></p> <p>There are significant aggregates flows from both of these quarries for major infrastructure and construction in London and South East England. These trains are some of the heaviest on the network, and as such would benefit from electrification in terms of journey speeds as well as decarbonisation.</p> <p>Major construction projects such as HS2 and Heathrow Airport Expansion (subject to the outcome of the current legal process) are expected to substantially increase demand for materials quarried from these locations.</p>
WSW I	Electrification	<p><u>Passenger</u></p> <p>Regional services from Salisbury north to Bristol and Bath via Westbury operate over this route. This route can act as a diversionary route for GWR long-distance high-speed services to the South West via Salisbury and the West of England line (South B).</p> <p><u>Freight</u></p> <p>Some flows of construction materials use this route, as well as some container traffic between Southampton and South Wales.</p>
WSW J	Electrification	<p><u>Passenger</u></p> <p>Extension of the Great Western electrification to the south west would enable both GWR and CrossCountry long-distance high-speed services to operate electrically to Plymouth and ultimately Penzance, together with GWR's sleeper services between London and Penzance. Regional services also operate between Plymouth and Penzance, while some of the urban routes serving Exeter and Plymouth could make use of main line electrification.</p> <p><u>Freight</u></p> <p>Long distance freight services operate to/from Cornwall via the main line, transporting china clay products and construction materials such as sand and cement. While the frequency of such services is limited, the distances</p>

		over which they operate are long. Electrification would benefit both decarbonisation and freight journey speeds, for example over the Devon Banks, and therefore main line capacity for all services.
WSW K	Battery	<p><u>Passenger</u></p> <p>The Cornwall branches appear well suited for battery technology, being short, self-contained and generally served by dedicated platforms which could be relatively easy to provide with the necessary recharging facilities. The choice of a common technology for several local routes would also allow development of a centralised facility and dedicated workforce to maintain the stock.</p> <p>The Mid Cornwall Metro proposals involve a potential new service pattern linking Newquay and Falmouth via Par and Truro. Electrification of the main line section would allow the branch lines to operate with battery traction, utilising the ability to charge from the overhead line where appropriate.</p> <p><u>Freight</u></p> <p>Several of the Cornish branches are used by china clay and construction materials traffic. These would require a bi-mode locomotive to be used which may incur residual diesel emissions if diesel is used as the bi-mode option.</p>

WALES (WAL)

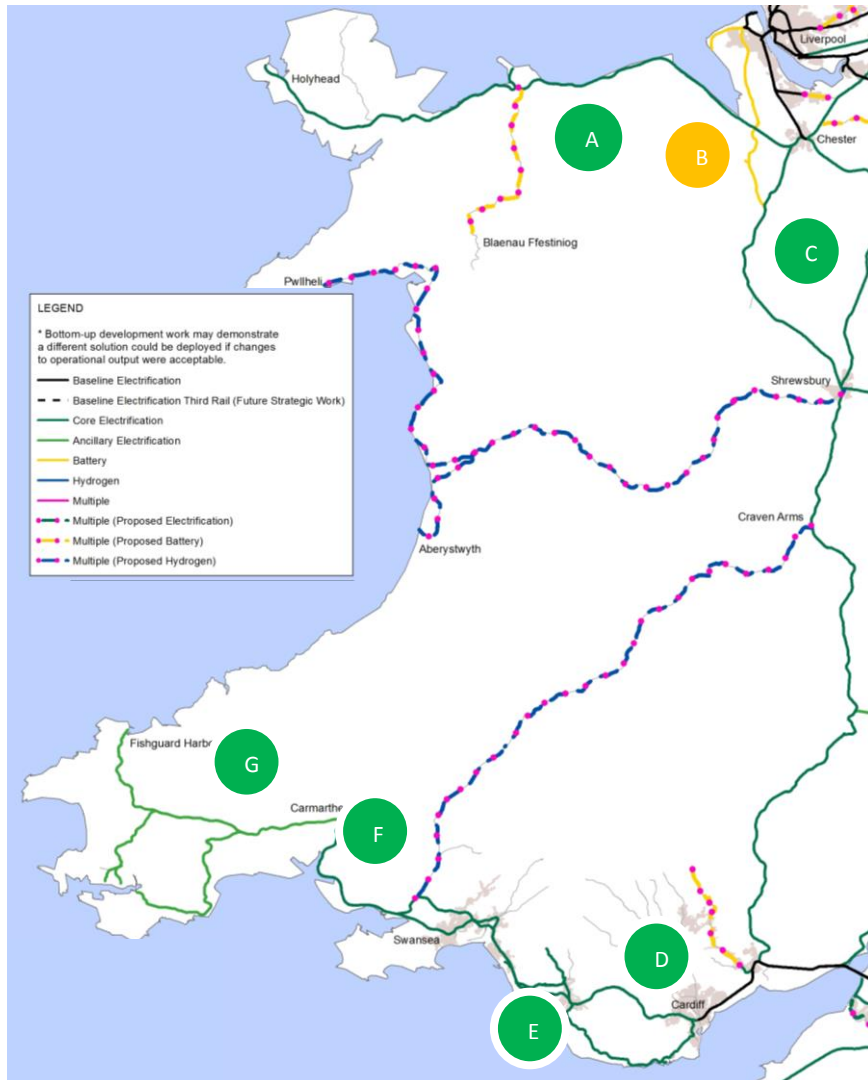

The following single option solution recommendations are made for Wales. Commentary supporting the single option recommendations is provided in the table overleaf.

- A North Wales Coast
- B Wrexham to Bidston
- C Chester and Crewe to Newport
- D Cardiff to Swansea
- E Cardiff to Maesteg via Barry
- F Swansea to Carmarthen
- G Carmarthen to West Wales Branch Lines

Segment	Technology	Commentary
Wal A	Electrification	<p><u>Passenger</u></p> <p>Long-distance services from operate to Holyhead from London Euston. Also mixed traffic route serving commuters to Chester and Manchester as well as tourist traffic to destinations along the north west coast and ferries at Holyhead.</p>
Wal B	Battery	<p><u>Passenger</u></p> <p>Local passenger services operate between Bidston and Wrexham.</p> <p><u>Freight</u></p> <p>Limited freight traffic serving cement and steel facilities on the route. These would require a bi-mode locomotive to be used, which may incur residual diesel emissions if diesel is used as the bi-mode option.</p>
Wal C	Electrification	<p><u>Passenger</u></p> <p>This is a key arterial route for a mix of long-distance journeys between North and South Wales, South Wales and Manchester and North Wales and the West Midlands, as well as various different commuter markets.</p> <p><u>Freight</u></p> <p>This route is the major freight route for services from South Wales to North Wales, the North West and the West Coast Main Line.</p>
Wal D	Electrification	<p><u>Passenger</u></p> <p>Long-distance services operate from London Paddington to Swansea. This route is also heavily used as a commuter route into both Cardiff and Swansea.</p>

		<p><u>Freight</u></p> <p>Major freight route, particularly for steel and petroleum traffic.</p>
Wal E	Electrification	<p><u>Passenger</u></p> <p>As well as being a diversionary line for long distance services, this serves intensive key commuter services into Cardiff.</p> <p><u>Freight</u></p> <p>This route sees some regular flows of cement and container traffic. This route also provides a key freight diversionary route.</p>
Wal F	Electrification	<p><u>Passenger</u></p> <p>Regional passenger services extend beyond Swansea.</p> <p><u>Freight</u></p>
Wal G	Electrification	<p>Moderate levels of freight traffic, chiefly oil and petroleum to and from the Milford Haven branch.</p>

WEST MIDLANDS (WM)

The following single option solution recommendations are made for the West Midlands. Commentary supporting the single option recommendations is provided in the table overleaf.

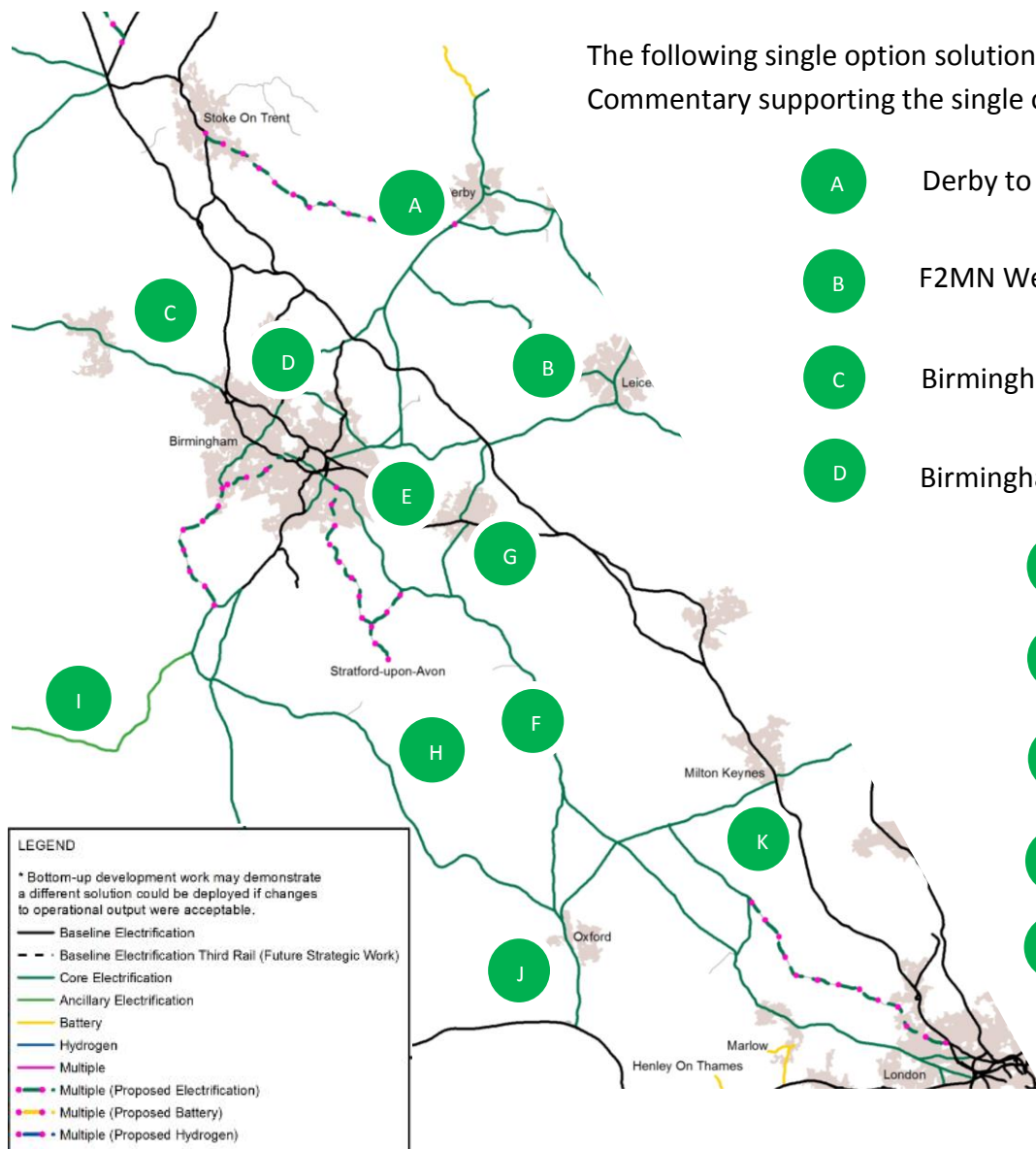

A

Derby to Birmingham

J

Banbury to Didcot

B

F2MN Western Section

K

Oxford to Bletchly (E/W Rail)

C

Birmingham to Shrewsbury

D

Birmingham North Freight Corridor

E

Nuneaton to Birmingham

F

Chiltern Main Line

G

Nuneaton to Leamington Spa

H

Worcester to Oxford

I

Worcester to Herford

Segment	Technology	Commentary
WM A	Electrification	<p><u>Passenger</u></p> <p>Long-distance high-speed CrossCountry services use this route linking the East Midlands and North East with the South West and South Coast. Midlands Rail Hub will add extra services to this corridor in the early 2030s.</p> <p><u>Freight</u></p> <p>This is a major freight corridor linking the West Midlands, Southern England and South Wales with the East Midlands, Yorkshire and the North East. It is heavily used by trains carrying containers, steel or oil. For this to be used to its maximum potential WM D would also need to be completed to provide access to existing terminals and the wider West Midlands as well as two proposed Strategic Rail Freight Interchange (SRFI) sites.</p>
WM B	Electrification	<p><u>Passenger</u></p> <p>CrossCountry regional services between Leicester and Birmingham operate on this route. This route can also provide a diversionary route for Midland Main Line services. Midlands Rail Hub will add extra services to this corridor in the early 2030s.</p> <p><u>Freight</u></p> <p>Major container flows from Felixstowe port utilise this route to access the Midlands and the North West, along with trains carrying construction materials. For this to be used to its maximum potential WM D would also need to be completed to provide access to existing terminals and the wider West Midlands as well as two proposed Strategic Rail Freight Interchange (SRFI) sites.</p>
WM C	Electrification	<p><u>Passenger</u></p> <p>There are a number of regional commuter services serving Wolverhampton and Birmingham. Long-distance high-speed services from London Euston also operate via Birmingham to Shrewsbury.</p>

		<p><u>Freight</u></p> <p>A number of freight services use this route, mainly carrying construction materials.</p>
WM D	Electrification	<p><u>Freight</u></p> <p>A freight-only corridor looping around North Birmingham which sees significant traffic flow to avoid major urban routes. This would be required to support full utilisation by freight for WM A and WM B. There are aspirations to reintroduce a passenger service along this corridor, including development work underway for a new station at Aldridge for services into Walsall on the western end of the route.</p>
WM E	Electrification	<p><u>Passenger</u></p> <p>Regional CrossCountry services operate between Nuneaton and Birmingham. Whilst not currently the case, as it is unelectrified, this route could provide a diversionary route for WMT trains between London and Birmingham via Nuneaton rather than Coventry.</p> <p><u>Freight</u></p> <p>Access to and from the WCML at Nuneaton to freight terminals in Birmingham means there is a significant traffic volume in this route. Trains from Felixstowe port extending beyond Nuneaton to Birmingham also use this route. The section west of Whitacre Jn/Water Orton is especially busy as a number of major freight corridors intersect on this portion.</p>
WM F	Electrification	<p><u>Passenger</u></p> <p>A mixture of long-distance high-speed services is provided by Chiltern and CrossCountry on all or part of this route. There are also regional and local passenger services operated by Chiltern at the southern part of the route and both Chiltern and WMT at the northern part with Chiltern providing through services from London up to Kidderminster (WM M).</p>

		<p><u>Freight</u></p> <p>Significant freight flow from Southampton via Didcot and Oxford joins this route at Banbury. This either continues to Birmingham or diverges at Leamington Spa destined for Nuneaton or the WCML. Significant flows of waste use the route south of Princes Risborough, with occasional trains carrying construction materials using the route between there and Banbury.</p>
WM G	Electrification	<p><u>Passenger</u></p> <p>Long-distance high-speed services from CrossCountry operate between Coventry (WCML) and Leamington towards the South West and South Coast. A local passenger service currently operates between Nuneaton and Leamington Spa with plans to grow this. There are also proposals to operate a service from Trent Valley stations via Nuneaton and Coventry to London as part of the long-term WCML released capacity.</p> <p><u>Freight</u></p> <p>Freight from the Chiltern Mainline (WM F) leaves at Leamington Spa using this route to access the WCML at Coventry or at Nuneaton.</p>
WM H	Electrification	<p><u>Passenger</u></p> <p>Long-distance high-speed Great Western Railway services from London Paddington utilise this route to serve Worcester and beyond. Alongside this there are a number of local services serving the north Cotswolds.</p>
WM I	Electrification	<p><u>Passenger</u></p> <p>Long-distance high-speed Great Western Railway services extend to Hereford alongside a number of regional commuter services towards Worcester and Birmingham.</p> <p><u>Freight</u></p> <p>Freight services from South Wales can use this route in conjunction with Wal C to access routes to the Midlands and the North East.</p>

WM J	Electrification	<p><u>Passenger</u></p> <p>Long-distance high-speed CrossCountry services operate from Birmingham to Reading and the South Coast. Proposed connectivity improvements at Birmingham airport and four tracking at Solihull will see an increase of services on this route. Long-distance high-speed Great Western Railway services from London Paddington utilise this route to serve Oxford as well as local services between Oxford and Didcot.</p> <p><u>Freight</u></p> <p>Significant freight flow from Southampton leave the GWML at Didcot to continue to Birmingham or diverges at Leamington Spa destined for Nuneaton or the WCML.</p>
WM K	Electrification	<p><u>Passenger</u></p> <p>Passenger services operated by Chiltern from Oxford to London Marylebone via the Chiltern Main Line (WM F). As part of the introduction of East-West Rail services passenger trains will operate between Oxford, Bedford and Cambridge. This segment forms the Western section of East-West Rail. A new section is being provided between Bedford and Cambridge, which may be delivered electrified.</p> <p><u>Freight</u></p> <p>Freight movements could be possible over East-West Rail, providing a direct link between Felixstowe port in East Anglia with the West Coast Main Line at Bletchley or onward toward Oxford and the Great Western Main Line. Freight from Southampton could also use the route to access the WCML. The extent to which East-West Rail will be utilised by freight is currently under review.</p>

NORTH WEST (NW)

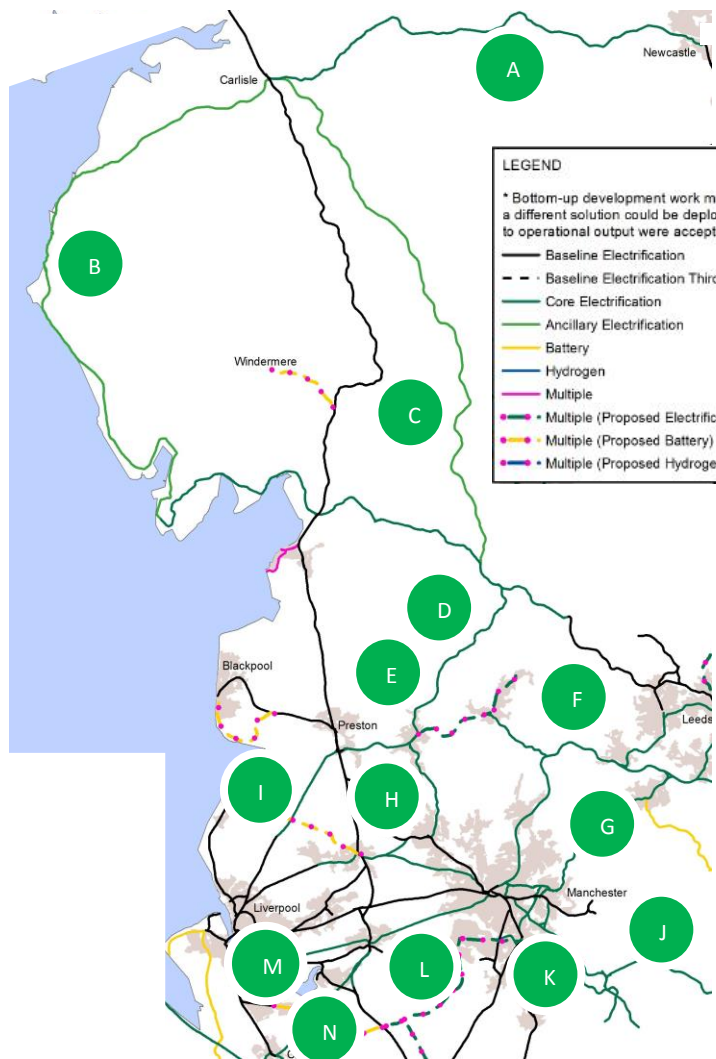

The following single option solution recommendations are made for the North West. Commentary supporting the single option recommendations is provided in the table

- | | | | |
|----------|------------------------------|----------|----------------------------------------|
| A | Newcastle to Carlisle | H | Wigan to Bolton and Manchester |
| B | Cumbrian Coast Line | I | Liverpool to Preston and Wigan |
| C | Skipton to Settle & Carlisle | J | Sheffield to Manchester |
| D | Hellifield to Bolton | K | Buxton to Manchester |
| E | Blackburn to Preston | L | Liverpool to Manchester via Warrington |
| F | Transpennine via Halifax | M | Chester to Warrington |
| G | West of Leeds | N | Crewe to Chester |

Segment	Technology	Commentary
NW A	Electrification	<p><u>Passenger</u> Regional passenger services linking Newcastle and Carlisle provide an important East-West link. Important diversionary route for WCML and ECML services.</p> <p><u>Freight</u> There are some cross-country freight flows using this route, with this being a route between ECML and WCML in the north of England. Due to the emerging Energy Coast Rail Upgrade project, there is scheduled to be an uplift in freight flows between Carlisle and Newcastle.</p>
NW B	Electrification	<p><u>Passenger</u> Regional passenger services operate along the Cumbrian Coast Line serving the many communities along West Cumbria, in particular serving the Sellafield nuclear decommissioning plant (a significant employer in Cumbria).</p> <p><u>Freight</u> Freight services operate throughout this route carrying commodities that are of national significance and involve transporting materials to/from the Low-Level Waste Repository at Drigg, and Sellafield. Freight also operates in and out of the Ports at Barrow and Workington. The new offshore coal mine is scheduled to use the Cumbrian Coast Line to transport out the coking coal which is being extracted.</p>
NW C	Electrification	<p><u>Passenger</u> Regional passenger services operating services between Carlisle and Leeds. The line offers a viable diversionary route for the WCML in times of perturbation.</p>

		<p><u>Freight</u></p> <p>Freight services avoiding the WCML operate along this route, particularly slower bulk services such as those carrying construction materials. Electric freight operation would be at least partially reliant on sections NW D and NW E also being electrified. Electrification would improve the attractiveness of the line's role as a diversionary route. There are a number of freight connections along the line including those at Kirkby Thore and Arcow Quarry.</p>
NW D	Electrification	<p><u>Passenger</u></p> <p>Regional passenger services operate between Clitheroe and Preston/ Manchester Victoria. There are limited passenger services between Clitheroe and Hellifield, only being used by the one weekly Sunday train service between Preston and Carlisle via Hellifield. Stakeholder aspirations are for passenger services to operate beyond Clitheroe to Hellifield.</p> <p>Electrification would enhance the attractiveness of the line's role as a diversionary route in conjunction with NW C.</p> <p>Electrification would reduce diesel services through Manchester Victoria, providing a longer-term air quality solution. Opportunity exists to build on the Bolton corridor electrification with potential alignment with any future doubling of Blackburn to Bolton line.</p> <p><u>Freight</u></p> <p>Predominantly a freight-only route between Clitheroe and Hellifield. As with passenger, electrification would enhance the attractiveness of the line's role as a diversionary route, linked with NW C.</p>
NW E	Electrification	<p><u>Passenger</u></p> <p>Work undertaken as part of the Preston CMSP work has identified some benefits in joining together services from Blackpool North and Blackburn by allowing these services to utilise electrification.</p> <p><u>Freight</u></p>

		This route provides a diversionary route for the WCML via Blackburn, particularly for slower bulk services such as those carrying construction materials. It also serves a major cement works.
NW F	Electrification	<p><u>Passenger</u></p> <p>There are regional services operating and this route is a secondary route to Manchester via Halifax rather than Huddersfield providing diversionary capability for Long-distance high-speed services operating on Transpennine routes. Services from Rochdale operate through Manchester using the Castlefield Corridor which has been designated congested infrastructure. As a result of this, this part of the route may benefit from electrification at an earlier stage and, alongside a number of other interventions, could play a significant part in the emerging Manchester Rail Strategy.</p>
NW G	Electrification	<p><u>Passenger</u></p> <p>Transpennine flows operate both long-distance high-speed services and regional services in this area. CrossCountry long-distance high-speed services also operate. Regional flows in the Manchester area are complex with multiple junctions and routes available. Transpennine route upgrade is currently being developed in this area and an opportunity exists to provide electrification in conjunction with this major programme.</p> <p><u>Freight</u></p> <p>Significant Transpennine route for freight traffic, especially for trains carrying biomass or construction materials.</p>
NW H	Electrification	<p><u>Passenger</u></p> <p>This would decarbonise commuter passenger services into Manchester and build on the recent Bolton electrification. Part of the route is part of NWEF 7, which is progressing through project development. Opportunities exist to synergise providing support in developing and delivering this.</p> <p><u>Freight</u></p> <p>A small number of freight trains use this route to carry containerised waste.</p>

NW I	Electrification	<p><u>Passenger</u></p> <p>Passenger services operate between Ormskirk and Preston, and Kirkby and Manchester Victoria (through Wigan Wallgate). These services interchange with the Merseyrail network at Ormskirk and Kirkby</p> <p>The Network Rail Liverpool City Region Strategic Rail Study identified options for funders, which included the possible extension of the Merseyrail network to Preston from Ormskirk, and Wigan from Kirkby.</p> <p>The new rolling stock for the Merseyrail network is looking at trialling battery technology with a view to extending the Merseyrail network without the need for third rail DC electrification. That said, NR are currently working with the Liverpool City Region Combined Authority to investigate the feasibility of a new station at Headbolt Lane, which would require a short extension to the third rail network.</p> <p>Current project looking at building a new station at Skelmersdale. This would see an extension of the network beyond Headbolt Lane towards Wigan.</p> <p><u>Freight</u></p> <p>Freight operates into and out of the Knowsley freight terminal which connects onto the network to the East of Kirkby on the Kirkby – Wigan line.</p>
NW J	Electrification	<p><u>Passenger</u></p> <p>Regional services operate between the East Midlands and North West using this corridor.</p> <p><u>Freight</u></p> <p>Very significant Transpennine route for freight traffic, particularly for construction materials originating in the Peak District.</p>
NW K	Electrification	<p><u>Passenger</u></p>

		<p>Self-contained commuter line between Buxton and Manchester.</p> <p><u>Freight</u></p> <p>Freight flows from various aggregates and construction terminals around Buxton accessing the Hope Valley line via Chinley.</p>
NW L	Electrification	<p><u>Passenger</u></p> <p>Regional passenger service between Manchester and Liverpool provided by Northern Rail. This route acts as a diversionary route between Manchester and Liverpool for other services including long-distance high-speed services operated by Transpennine. These services feed into the Castlefield Corridor in Manchester which has been designated congested infrastructure. As a result of this, this route would benefit from electrification at an early stage and, alongside a number of other interventions, is likely to play a significant part in the emerging Manchester Rail Strategy.</p>
NW M	Electrification	<p><u>Passenger</u></p> <p>Regional services operate from the North Wales Coast, through Chester and Manchester. These travel along the Castlefield Corridor in central Manchester. There is also the relatively new service between Leeds, via Bradford Interchange, and Chester.</p> <p>Passenger services operate between Chester and Liverpool Lime Street via the reinstated Halton Chord. There are aspirations to extend these services into Wales.</p> <p><u>Freight</u></p> <p>There are a number of freight sidings along the route including those on the branch to Ellesmere Port.</p>
NW N	Electrification	<p><u>Passenger</u></p> <p>A long-distance high-speed service extends from Crewe to Chester and onward to Holyhead. There are also regional services including long-distance services provided by Transport for Wales.</p>

		<u>Freight</u>
--	--	-----------------------

		There is some freight on this corridor, mostly carrying timber.
--	--	-----------------------------------------------------------------

MULTIPLE OPTION SOLUTIONS

Section 5.7 outlined that there are areas of the network where there is not currently a clear technological choice for decarbonisation technology deployment.

For those areas of the network which have been highlighted in the maps covered in the previous section an economic and operational analysis has been undertaken to identify the optimal technology to deploy. The outcomes of the single option solutions and any interfacing operational constraints and synergies have also been considered.

These considerations and synergies include:

- fleet homogeneity;
- depot and stabling requirements;
- any cross-modal fuelling/charging benefits; and
- asset impact compared with surrounding geographical infrastructure.

The maps and tables provided over the coming pages identify the “multiple option” segments from each of the geographic areas covered in the previous section and outline the optimum technology to be deployed where this can be identified or provide rationale for why a decision would be better made at a later date.

NORTH EAST, NORTH YORKSHIRE AND HUMBERSIDE (NENYH)

The following multiple option solution recommendations are made for the North East, North Yorkshire and Humberside. Commentary supporting the multiple option recommendations is provided in the table overleaf.

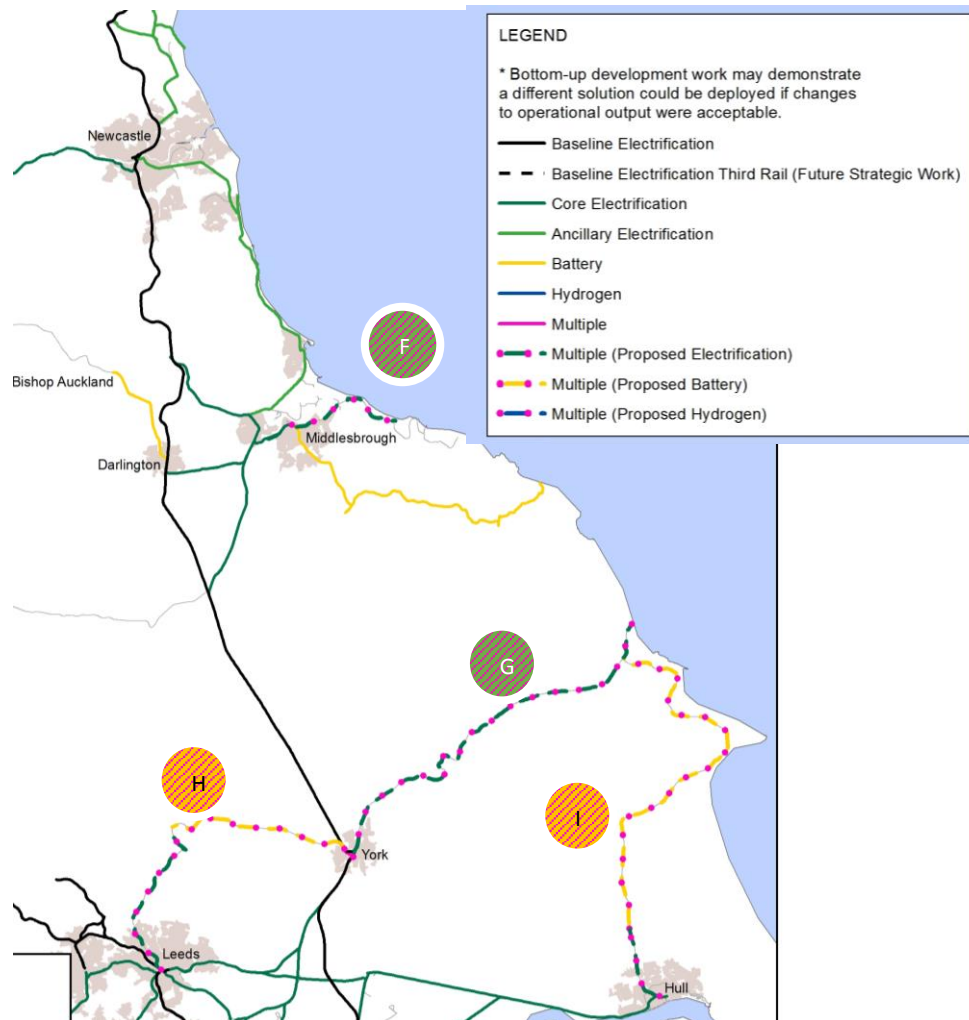

- F Saltburn to Middlesbrough
- G Scarborough to York
- H York to Leeds via Harrogate
- I Hull to Scarborough

Segment	Recommended Technology	Commentary
NENYH F	Electrification	This segment sees passenger services to Saltburn. It also sees freight flows of steel and potash to and from Skinningrove in North Yorkshire. The frequency of these services would suggest electrification of this area is required, although the long-term viability of this flow is uncertain given the current status of the UK steel market. A wider range of freight commodities use the western part of this section, as far as the Redcar/Tees Dock terminal complex, including container traffic to and from Tees Dock. As with NENYH D depending on the delivery of electrification in this area an interim or permanent deployment of hydrogen may be required for passenger services.
NENYH G	Electrification	Primarily used for Transpennine long-distance high-speed services from Scarborough to Manchester and Liverpool as well as additional planned regional commuter services to York this route would benefit from electrification for these services. At over forty miles this route is approaching the maximum capability of current battery technology, and given train type, wider operations to the NW and intensity of service electrification appears optimal.
NENYH H	Electrification from Leeds to Harrogate, battery to York	Used by a mixture of stopping and semi-fast services by Northern and LNER this forms a key part of the Leeds suburban network to Horsforth and Harrogate. Mostly services are regional commuter services to York and Leeds. This could act as a potential diversionary route between York and Leeds. Electrification to at least Harrogate is recommended.
NENYH I	Electrification to Beverley, Battery or Hydrogen to Scarborough	Primarily used by services from Hull to Scarborough. Services from King's Cross to Beverley could benefit from electrification which would reduce this gap. This could lead to a mixture of battery and electrification being optimal. Given that services operate from this route to the Midlands and depending on the timescales on which electrification is provided in the wider geographic area, hydrogen rolling stock may be required as either a temporary or permanent solution. At over fifty miles this route is approaching the maximum capability of

		current battery technology but will be able to be operated using this based on battery development forecasts and electrification as far as Beverley.
--	--	------------------------------------------------------------------------------------------------------------------------------------------------------

EAST MIDLANDS, YORKSHIRE AND LINCOLNSHIRE (EMYL)

The following multiple option solution recommendations are made for the East Midlands, Yorkshire and Lincolnshire. Commentary supporting the multiple option recommendations is provided in the table overleaf.

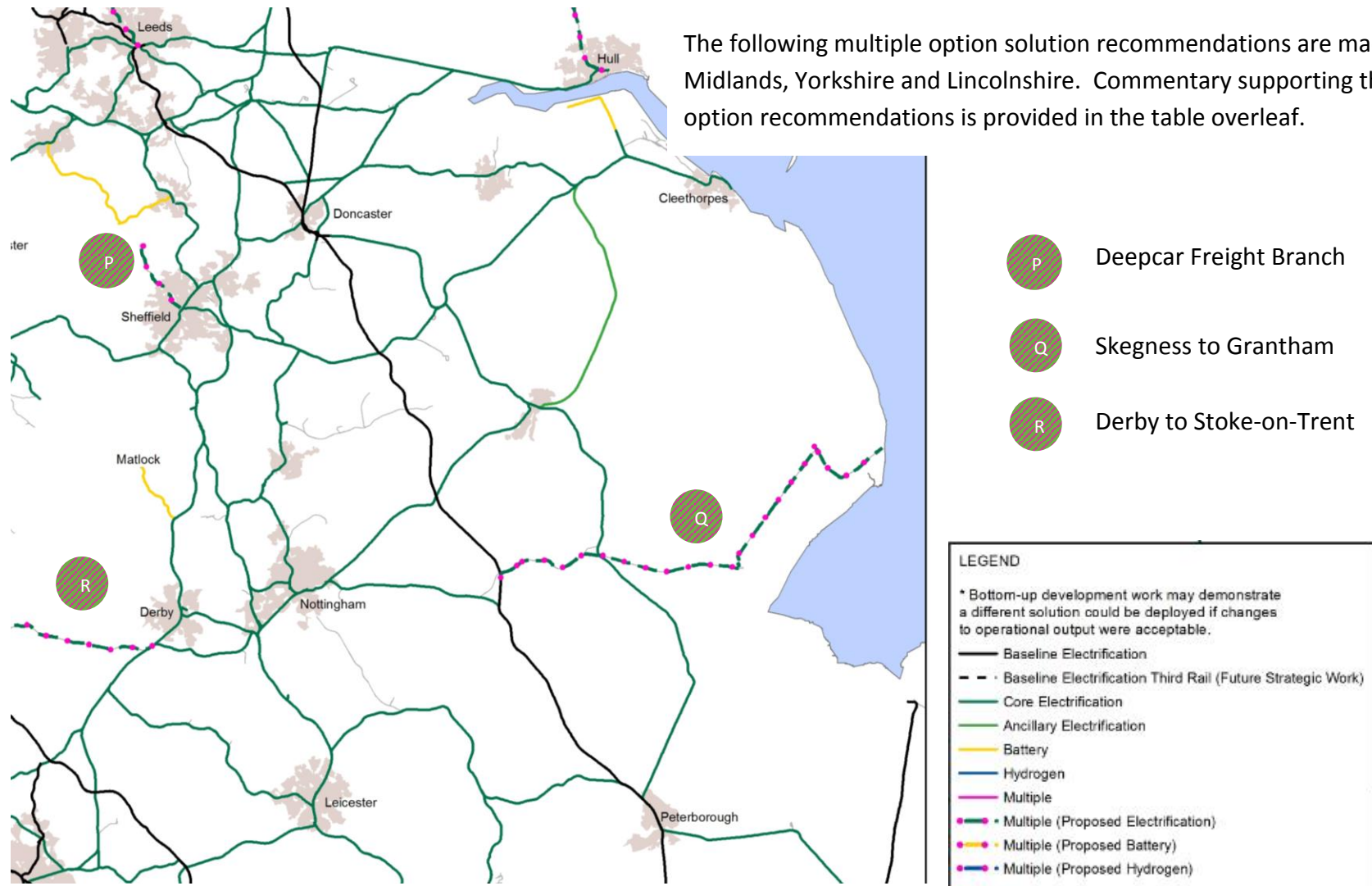

Segment	Recommended Technology	Commentary
EMYL P	Electrification	Whilst this freight-only route has some traffic it is infrequent. It is possible that services operated by a bi-mode locomotive would be a more appropriate application. The topography of this route means there is a significant gradient for freight traffic to overcome. Electrification is likely to be the optimal solution to this. If operation was to occur with an alternative traction solution this may incur residual diesel emissions if diesel is used as the bi-mode option. There are local aspirations to introduce passenger services on this branch.
EMYL Q	Electrification	Regional passenger service operates from Skegness to the ECML and Midlands. At almost sixty miles this would be approaching the maximum range of current battery operations. This may require hydrogen on current operational capability if it is not electrified. There are a number of freight flows from Boston which use this route where electrification would be needed without having to occur residual emissions.
EMYL R	Electrification	This route is currently used by an hourly Crewe-Derby service. There are aspirations to both increase the frequency of this service and extend its operation to Manchester Airport. There is a long-term aspiration to gauge clear this route for freight traffic to be able to use this route to access the WCML from the Midlands. If this was to occur and freight were to use this route on a frequent basis electrification would be required.

ANGLIA (ANG)

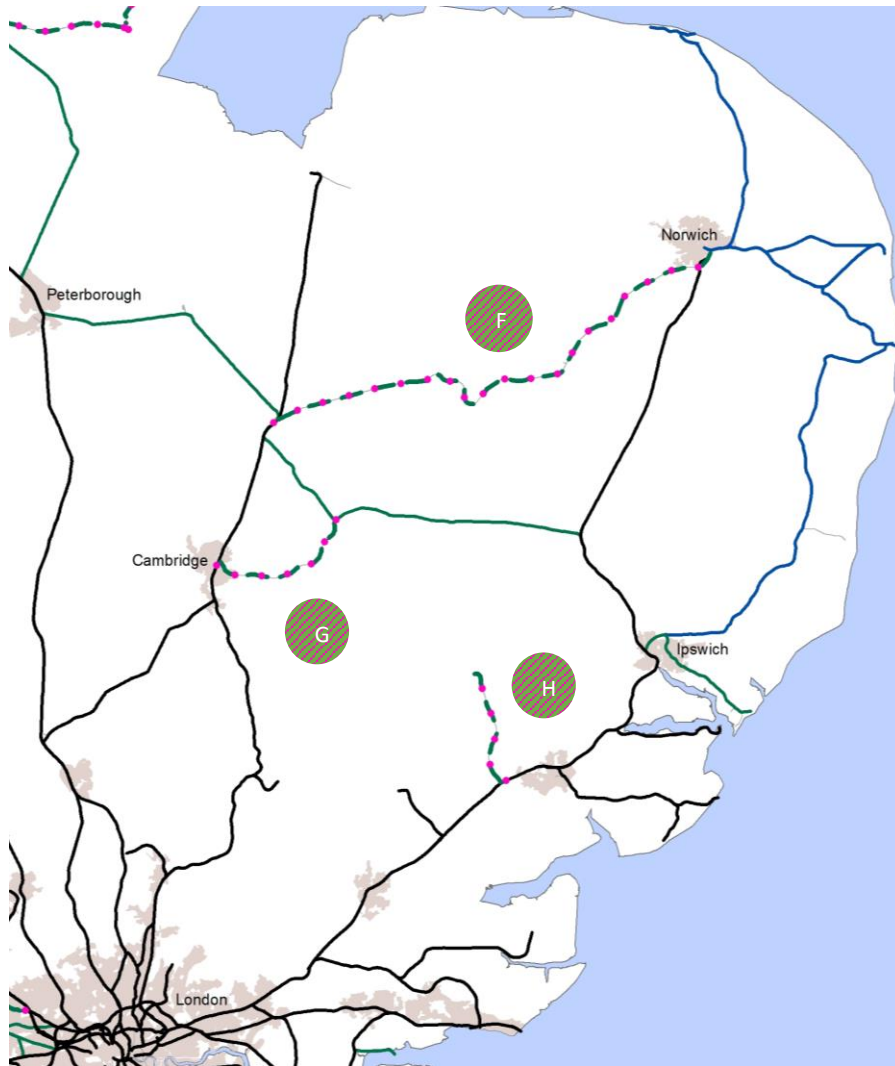

The following multiple option solution recommendations are made for Anglia. Commentary supporting these recommendations is provided in the table overleaf.

- F Norwich to Ely
- G Newmarket to Cambridge
- H Sudbury Branch

LEGEND

* Bottom-up development work may demonstrate a different solution could be deployed if changes to operational output were acceptable.

- Baseline Electrification
- Baseline Electrification Third Rail (Future Strategic Work)
- Core Electrification
- Ancillary Electrification
- Battery
- Hydrogen
- Multiple
- Multiple (Proposed Electrification)
- Multiple (Proposed Battery)
- Multiple (Proposed Hydrogen)

Segment	Recommended Technology	Commentary
Ang F	Electrification	This route is used mostly by regional passenger services between Norwich and Ely (and subsequently onto Cambridge/Stansted Airport and to Peterborough). This also includes the Norwich to Nottingham, Manchester and Liverpool service. Alignment with proposals made for other geographies will require consideration. This would suggest electrification to enable this service to operate electrically throughout. There are also some freight services on this branch which would benefit from electrification. If a bi-mode locomotive would be required, this may incur residual diesel emissions if diesel is used as the bi-mode option.
Ang G	Electrification	This route is a short branch used by passenger services between Ipswich and Cambridge. The Cambridgeshire Corridor Study forecasts passenger growth on this route by 2041, with indicative infrastructure including some doubling of the Newmarket single line section and a turnback at Newmarket. The economies of scale of electrification within a wider enhancement may be a viable approach. Whilst passenger services could be operated by battery rolling stock depending on recharging times at Cambridge and Ipswich there is currently uncertainty about freight traffic onto East-West rail from Felixstowe. If this was to materialise this segment would need to be electrified. This would also provide a homogeneous fleet in the area.
Ang H	Electrification	This branch could operate battery services. However, given that this would be the only area in the region which would use battery this would provide a relatively small fleet. Equally if services were to be extended onto the GEML this could support further electrification. Given the length and complexity of the segment it may be more cost beneficial simply to electrify to achieve fleet homogeneity.

SOUTHERN (SOUTH)

The following multiple option solution recommendations are made for Southern. Commentary supporting these recommendations is provided in the table overleaf.

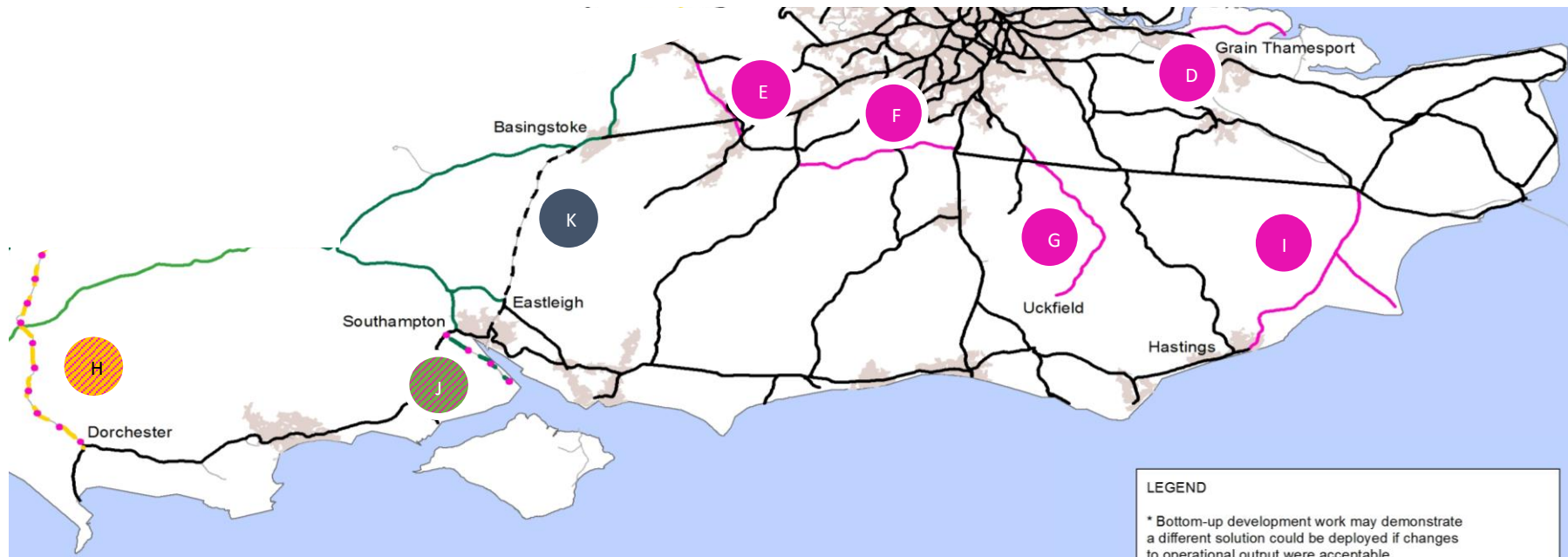

- | | |
|---------------------------------|-----------------------------------------------------|
| D Isle of Grain Branch | H Dorchester to Castle Cary |
| E Aldershot to Wokingham | I Ashford to Hastings (inc Dungeness Branch) |
| F Redhill to Guilford | J Fawley Branch |
| G Uckfield Branch | K Southampton to Basingstoke |

LEGEND

* Bottom-up development work may demonstrate a different solution could be deployed if changes to operational output were acceptable.

- Baseline Electrification
- - Baseline Electrification Third Rail (Future Strategic Work)
- Core Electrification
- Ancillary Electrification
- Battery
- Hydrogen
- Multiple
- Multiple (Proposed Electrification)
- Multiple (Proposed Battery)
- Multiple (Proposed Hydrogen)

Segment	Recommended Technology	Commentary
South D	Third rail electrification or Battery	This branch is used exclusively by freight traffic currently. Medway Council have successfully bid to the Housing Infrastructure Fund to develop proposals to introduce passenger services into this area. This is to facilitate housing growth on the Hoo Peninsula. As part of this, the optimum traction solution, including possible extension of the third rail system, requires confirmation. Electrification would allow direct London services to be integrated. It is possible a bi-mode locomotive would be required for freight services. This may incur residual diesel emissions if diesel is used as the bi-mode option.
South E	Third rail electrification of Battery	The route provides important cross-regional links between Reading and Gatwick and is part-electrified already. RSSB has commissioned a study with ORR and Network Rail to explore the feasibility of infill third rail electrification on the remaining diesel routes in the South East. Electrification would reduce journey times and provide benefits from integrating services, giving greater connectivity and more destinations across the South East. If third rail infill is not considered possible it is likely a battery solution would be required.
South F	Third rail electrification or Battery	The route provides important cross-regional links between Reading and Gatwick and is part-electrified already. RSSB has commissioned a study with ORR and Network Rail to explore the feasibility of infill third rail electrification on the remaining diesel routes in the South East. Electrification would reduce journey times and provide benefits from integrating services giving greater connectivity and more destinations across the South East. If third rail infill is not considered possible it is likely a battery solution would be required.
South G	Third rail electrification or Battery	This line with has diesel passenger services operating to London Bridge via Hurst Green, from where the route is electrified. RSSB has commissioned a study with ORR and Network Rail to explore the feasibility of infill third rail electrification on the remaining diesel routes in the South East. Electrification would remove the last diesel trains from London Bridge and improve integration with other service groups. If electrification is not possible it is likely a battery solution would be required.

South H	Battery	This route is used by a regional service between Weymouth and Exeter and Bristol. Assuming the routes under WSW to enable this are electrified this route could be operated using battery.
South I	Third rail electrification or Battery	<p>This line links Ashford and Eastbourne via Hastings and is served by a regional passenger service. There is an ambition to extend the operation of SouthEastern HS1 services to Hastings, which would require electrification or the design of a new bespoke bi-mode train. RSSB has commissioned a study with ORR and Network Rail to explore the feasibility of infill third rail electrification on the remaining diesel routes in the South East. Electrification would also allow integration with other services in Kent.</p> <p>There are freight services which operate on the Dungeness branch. It is likely a bi-mode locomotive would be required for freight services. This may incur residual diesel emissions if diesel is used as the bi-mode option.</p>
South J	Electrification	Freight-only branch seeing some freight traffic.
South K	Further work required	The route from Southampton to Basingstoke is heavily used by both freight and passenger services. The current freight fleet in this area operates using diesel services due to their operation beyond the electrified network and the limited number of locomotives capable of using third rail traction as well as a number of operational limitations. Whilst regional passenger services use the third rail system, long-distance high-speed services from CrossCountry also use diesel traction. Careful consideration will be required in assessing this corridor and the solution provided. The significant volume of freight from Southampton may lead to consideration of conversion to 25kV OHL. Conversion would cause significant service disruption to both passengers and freight during any change over period. Alternatively, a power upgrade could be provided enhancing the third rail rail's current flow to 6.8kA as has been done in routes around the Channel Tunnel in Kent. This could allow an AC/DC freight locomotive to operate.

WESTERN AND SOUTH WEST (WSW)

The following multiple option solution recommendations are made for Western and the South West. Commentary supporting these recommendations is provided in the table overleaf.



Segment	Recommended Technology	Commentary
WSW L	Electrification	<p>A relatively short length, but well-utilised, commuter service operates from Severn Beach to Bristol. This service could be operated using battery traction, however, given the relatively short distance involved and the potential to improve resilience and a diversionary route for freight from Severn Beach this route may benefit from electrification.</p> <p>Electrification would also benefit the containerised waste services which operate over this route, between west London and the waste-to-energy plant at Severnside, near Severn Beach.</p>
WSW M	Electrification	<p>This route is recommended as a candidate for full electrification or else hydrogen, since it is not ideally suited for battery technology (only). This is because of the relatively long travel distance and high-speed performance that would be required (line speeds up to 85mph are currently being planned); together with the limited opportunity for main line recharging. There would also be significant operational challenges in maintaining the current timetables, based on the likely requirements for recharging time (c. 15 minutes), particularly at the Barnstaple end.</p> <p>Journey time improvements and capacity enhancements for Barnstaple-Exeter are under active consideration through the North Devon Line study. This work is being co-ordinated with proposals to reintroduce regular passenger services on the Okehampton-Exeter route, which shares some of the same infrastructure. Any new technology could be developed in a consistent manner for the network serving Exeter, including the routes from Barnstaple, Okehampton and Exmouth.</p>
WSW N	Electrification	<p>A GWR long-distance high-speed service leaves the mainline for Newquay in the summer months. It may be possible to provide this service with a bi-mode option or (given the relative distance from the mainline to Newquay) electrification may be possible. Some freight traffic is found with China Clay trains running between Goonbarrow and Par which would also benefit from electrification.</p>

WALES (WAL)

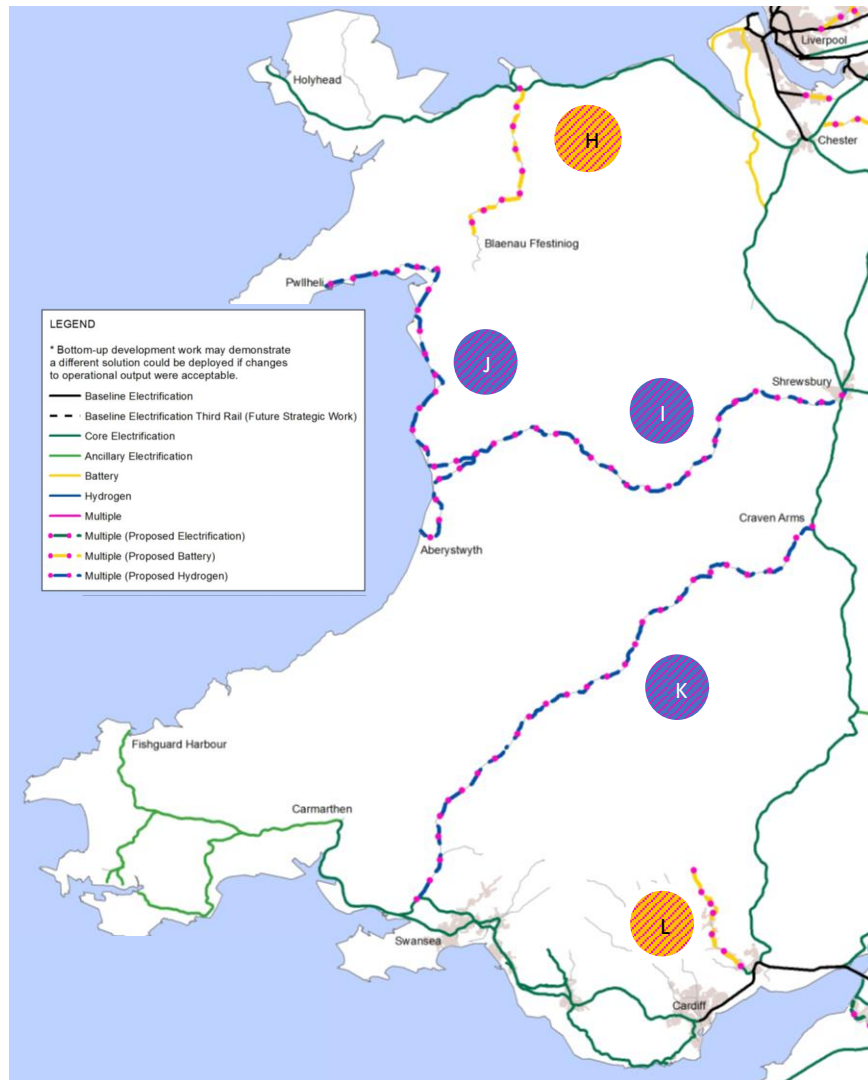

The following multiple option solution recommendations are made for Wales. Commentary supporting the multiple option recommendations is provided in the table overleaf.

-  H Llandudno to Blaunau Ffestiniog
-  I Shrewsbury to Machynlleth
-  J Pwllheli to Aberystwyth
-  K Craven Arms to Llanelli
-  L Ebbw Vale Branch

Segment	Recommended Technology	Commentary
Wal H	Battery	Regional passenger service operate as a shuttle along the line. A battery service would be optimal.
Wal I	Hydrogen	Regional and long-distance services from West Wales to Shrewsbury and the West Midlands, including seasonal tourism and university markets. Significant distances covered would suggest hydrogen is most suitable for these areas.
Wal J	Hydrogen	
Wal K	Hydrogen	Rural route through central Wales. This route is not used by freight traffic which operates via Hereford, but can act as a freight diversionary route. Length of route would suggest hydrogen is optimal solution.
Wal L	Battery	Branch line from Newport to Ebbw Vale. Service currently operates to Cardiff and acts as a strong commuter market. Services to Newport are committed in the franchise and are due to start in late 2021 at the earliest. Whilst battery operation could be accommodated for services to Cardiff the available recharging time may be too short to allow battery operations to Newport.

WEST MIDLANDS (WM)

The following multiple option solution recommendations are made for the West Midlands. Commentary supporting the multiple option recommendations is provided in the table overleaf.

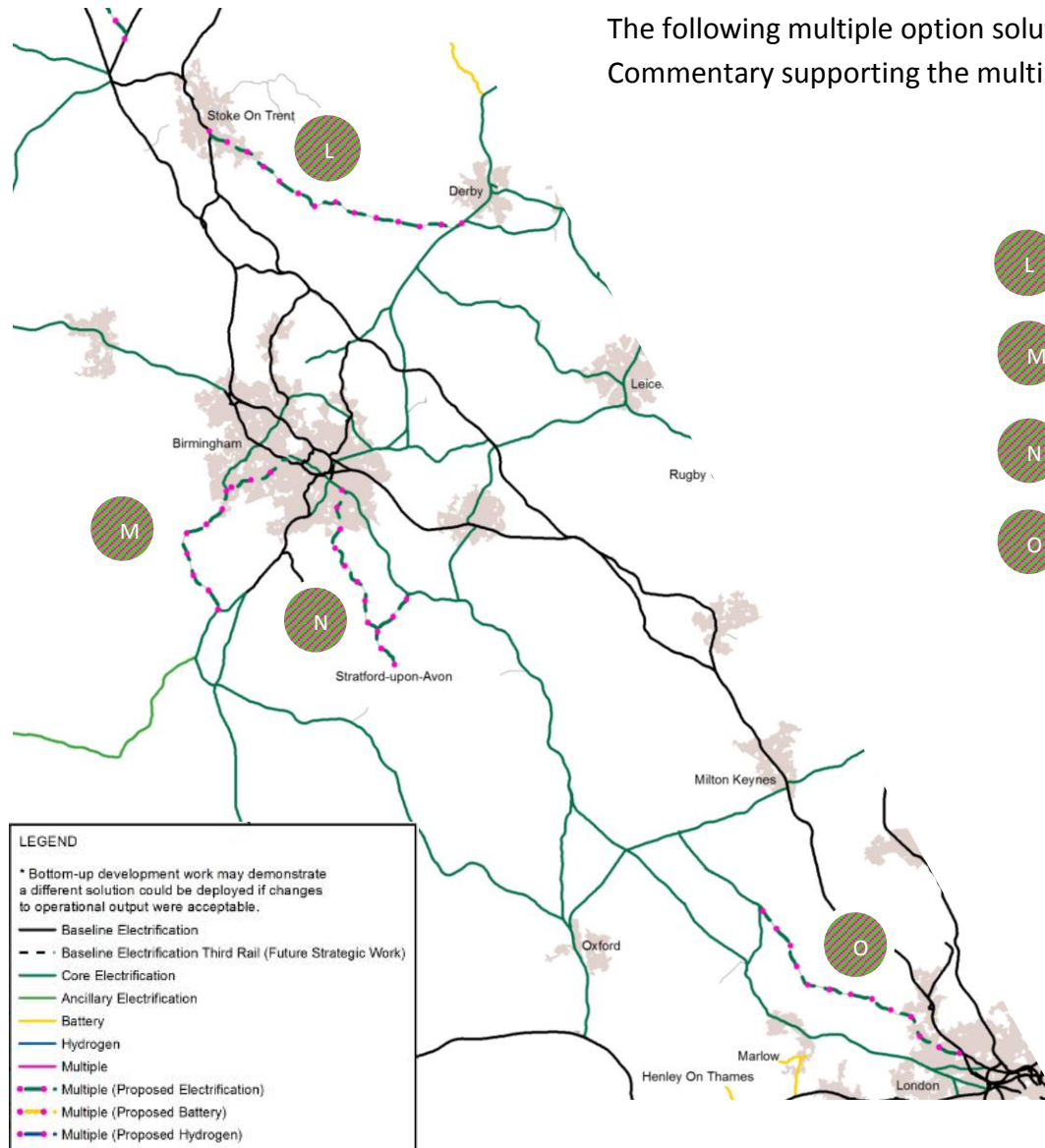





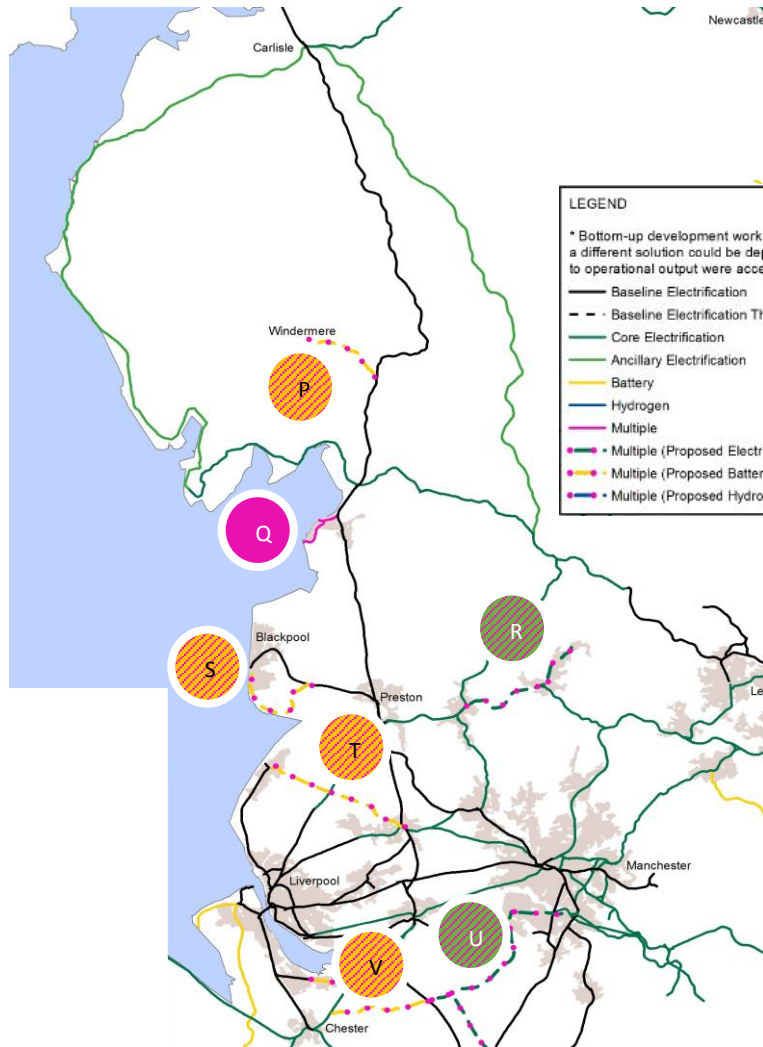

- L** Derby to Stoke-on-Trent
- M** Droitwich Spa to Birmingham Snow Hill
- N** Stratford-Upon-Avon to Chiltern Main Line
- O** London Marylebone to Aylesbury

Segment	Recommended Technology	Commentary
WM L	Electrification	This route is currently used by an hourly Crewe-Derby service. There are aspirations both to increase the frequency of this service and extend its operation to Manchester Airport. There is a long-term aspiration to gauge clear this route for freight traffic to be able to use this route to access the WCML from the Midlands. If this was to occur and freight to use this route on a frequent basis electrification would be required.
WM M	Electrification	West Midlands Trains and Chiltern operate a regional commuter service to Birmingham Snow Hill, Leamington and Stratford-upon-Avon along this route. The Chiltern services extend to London. The intensity of use and service frequency coupled with operation using the same fleet to Shrewsbury and Worcester would suggest electrification is the optimal technology application. With this area proposed for electrification this would allow WM K to be considered and delivered in a strategic manner in conjunction with WM F. Some freight traffic uses this route south of Stourbridge to access the steel terminals at Round Oak. Very limited freight traffic uses the section between Stourbridge and Birmingham, including occasional intermodal services.
WM N	Electrification	Chiltern services operate to and from Leamington Spa to Stratford-Upon-Avon with WMT providing services to and from Stratford-upon-Avon to Birmingham via both directions. Whilst the distances involved could be operated using battery rolling stock these services operate beyond Birmingham over WM M. If a homogenous fleet were to be provided for the services operated on both of these segments it would require electrification. This segment should be carefully considered as part of wider electrification of WM F and WM M.
WM O	Electrification	The Aylesbury branch from London Marylebone operates a regional commuter service into London. This could be operated using battery rolling stock utilising electrification as far as Princes Risborough, but it is likely that the intensity of service would favour electrification to London. This would provide an added benefit as rolling stock is from the same pool as services to Banbury, which is electrified as part of WM F.

NORTH WEST (NW)



The following multiple option solution recommendations are made for the North West. Commentary supporting these recommendations is provided in the table overleaf.

-  Windermere to Oxenholme
-  Heysham/Morecambe to WCML
-  Colne to Blackburn
-  Blackpool South Branch
-  Southport to Wigan
-  Mid-Cheshire Line (east of WCML) and Middlewich Branch
-  Mid-Cheshire Line (west of WCML)

Segment	Recommended Technology	Commentary
NW P	Battery	Regional passenger service operating between the WCML and Windermere. Service could operate as battery or as a short extension of electrification from the WCML.
NW Q	Electrification to Morecambe, battery beyond	Regional passenger service operating between the WCML and Heysham. Service could operate as battery or as a short extension of electrification from the WCML. Given relative short distance from the WCML to Morecambe and the number of services which operate to the wider geographic area including as far as Leeds electrification to Morecambe would enable these services to operate as electric throughout rather than have battery traction for the last 1% of a journey.
NW R	Electrification	Regional passenger service between Colne and Blackburn could operate as battery or as a short extension of electrification. Electrification would provide completed east-west link towards Halifax and Leeds.
NW S	Battery	Regional passenger service operating between the electrified Blackpool branch and Blackpool South. Service could operate as battery or as a short extension of electrification from the WCML. As there is no freight on this section and an existing tram system in Blackpool this segment could be converted to light rail and integrated into the wider Blackpool tram network or be a candidate for very light rail.
NW T	Battery	Regional passenger services operate between Southport and Manchester. Could operate as battery or as a short extension of electrification.
NW U	Electrification	Passenger services operates between Manchester and Chester. Moderate levels of freight including biomass and waste.

NW V	Battery	Passenger service operates between Manchester and Chester. Service could operate as battery or as a short extension of electrification to provide a more frequent passenger service. No regular freight services.
-------------	---------	-------------------------------------------------------------------------------------------------------------------------------------------------------------------------------------------------------------------

APPENDIX 9 – STRATEGIC ASSUMPTIONS, RISKS AND OPPORTUNITIES

STRATEGIC ASSUMPTIONS

In order to develop this document, the future Programme Business Case and the programme a number of strategic assumptions have been required to be made. These assumptions form the basis of the analysis and recommendations made in this and future TDNS document and are outlined in the table below.

Assumption	Use within TDNS
The national grid will achieve net zero greenhouse gas emissions targets by 2050 such that any electricity taken from the grid by 2050 will be zero emissions. Up until that time the forecast grid mix from the Department for Business, Energy and Industrial Strategy will be assumed	Ultimately assumes that any technology which uses electricity by 2050 will be zero-carbon
Electricity will be available where and when it is needed to be provided in order to achieve proposals made by TDNS	The specific locations of connection points into the national electrical distribution network requires further work. It is assumed sufficient national grid power will be available to support the recommendations made
The extent to which a nationwide hydrogen distribution network will be provided are unclear. It is assumed that hydrogen fuel for rail will be either manufactured within a depot or delivered to a depot and used to directly refuel trains.	Costs included in WLCBC model are for hydrogen manufactured in a depot provided from RSSB T1199
Whilst early indications show that the existing electrified network is not capable of all services which operate over it using electrification due to power limitations, TDNS does not explore in detail the work required to rectify this.	The scope of TDNS has not included the existing electrified network. Initial work undertaken to support TDNS recommendations has indicated the scale of the issue. Regional traction power strategies should be undertaken by Network Rail to provide more detailed assessment

Assumption	Use within TDNS
Any new rolling stock introduced to achieve decarbonisation targets will as a minimum match the capability and reliability of trains they replace.	Factored in through the technology assessment decision tree
Required rolling stock and infrastructure will be able to be delivered in a timely manner in line with recommended volumes from the national supply chain	Significant volumes of rolling stock and infrastructure will be required. This will be explored in greater detail as part of the TDNS PBC.
A technical working group was held to collectively agree the characteristics of electric, battery and hydrogen trains.	These technology assumptions have been used for alternative traction rolling stock. It is proposed TDNS is refreshed on a five yearly basis to factor in any future changes in technology
Third Rail electrification will only be considered in areas where it make technical and operational sense to do so	This is to be considered more widely as part of the RSSB, ORR, NR joint study
The choices available to funders are not limited by funding availability.	The spend profile provided in the financial case outlines the various different cash flow forecasts to achieve the various decarbonisation options
Zero emissions may be required in rail. Potential almost-zero scenarios identified to inform government of potential opportunity	TDNS outlines four possible core options, achieving 80% reduction by 2050, 95% reduction by 2050, zero by 2050 and zero by 2040.
The Transport Scotland Decarbonisation Action Plan outlines the programme of traction decarbonisation for Scotland's domestic passenger services. TDNS will replicate the work proposed under the Decarbonisation Action Plan.	The work presented within TDNS replicates that provided by Transport Scotland and Scotland's Railway.
Network Rail does not need land beyond its existing land ownership in order to provide equipment to realise decarbonisation of traction	This will be required to be considered on a project by project basis as designs are developed. No cost has been included for this within this appraisal.

STRATEGIC RISKS AND OPPORTUNITIES

As well as the strategic assumptions which have been made there are a number of strategic risks and opportunities which may affect the successful delivery of the programme and achieving emissions reductions for traction. These are outlined respectively in the tables below.

Risk	Likelihood	Impact	Mitigation
There is a risk that introduction of decarbonisation solution increases the risk of injury both to members of the public and the railway workforce	Low	High	All established risk management processes should be followed when introducing new electrical systems
There is a risk that as a result of global climate change that decarbonisation solutions introduced may reduce network performance as it becomes more susceptible to extreme weather events	Low	Low	Work undertaken by the Network Rail Weather Resilience and Climate Adaptation (WRACA) study should be considered and implemented appropriately
There is a risk that changes in the political climate over the next thirty years may change the focus of investment away from decarbonisation of the economy	Medium	High	Covid-19 has demonstrated that funding may need to be diverted as events and political decisions emerge. TDNS refresh should reflect any known changes.
There is a risk that there will be insufficient capacity in the rail network to achieve the required modal shift to meet surface transport decarbonisation	High	High	DfT's Transport Decarbonisation Plan will begin to outline the modal shift requirements of rail to support wider surface transport decarbonisation
There is a risk that misalignment between the Digital Railway Long-term deployment plan (LTDP) and TDNS programme of decarbonisation may lead to inefficient spending	High	Medium	Major national programmes such as LTDP require careful consideration. LTDP and TDNS programme of decarbonisation should be integrated once the latter is established.

Risk	Likelihood	Impact	Mitigation
<p>There is a risk that misalignment between the rail industry Air Quality Strategic Framework and TDNS programme of decarbonisation may lead to inefficient spending</p>	High	Medium	<p>Major national programmes such as rolling stock retrofit, and new infrastructure required to support the rail industry Air Quality Strategic Framework require careful consideration. Air Quality interventions will need to take cognisance of the TDNS programme of decarbonisation should be integrated once the latter is established.</p>
<p>There is a risk that cost escalation of all project types at an early stage may undermine long-term support for extensive traction decarbonisation</p>	Low	High	<p>Major lessons learned from previous electrification projects in previous years are clearly documented and there are active workstreams in both Network Rail and the supply chain to embed these into project delivery. Learning lessons from the earliest introductions of battery and hydrogen rolling stock will be critical as these are more widely introduced.</p>
<p>There is a risk that the relatively low volumes of alternative traction types proposed may result in small levels of market appetite from suppliers</p>	Medium	Medium	<p>The necessity for battery and hydrogen rolling stock is clear. Whilst at an end state the relative volumes of technology are low the need to deploy interim solutions on the journey to the end state may increase overall levels. The volumes are likely to encourage existing fleet retrofits or a modular approach using an existing vehicle “platform” rather</p>

Risk	Likelihood	Impact	Mitigation
			than a bespoke unit just for the UK.
There is a risk that capital carbon reduction targets are established which carry high levels of delivery risk in achieving them, this may result in inefficient delivery expenditure	Low	High	The difficulty of achieving a zero emissions position for 2040 has been outlined. If zero emissions targets within this timescale or earlier are expected of rail this will increase delivery risk and subsequently costs.

Opportunity	Likelihood	Impact	Mitigation
There is an opportunity to use TDNS to identify the criticality of rail as part of the “future of freight” work being undertaken by DfT	High	High	TDNS has been working closely with the DfT’s Future of Freight team to understand and ensure alignment.
There is an opportunity to use TDNS to identify the criticality of rail as part of the Transport Decarbonisation Plan being undertaken by DfT	High	High	TDNS has been working closely with the DfT’s Transport Decarbonisation Plan team to understand and ensure alignment.
There is an opportunity to use the volume of infrastructure and rolling stock required as part of TDNS to provide a long-term high quality job market which will benefit to wider economy	High	High	TDNS has outlined the volumes of infrastructure and rolling stock required. If this is implemented these roles would emerge naturally.
There is an opportunity to consider and include air quality benefits which have not been economically captured within the TDNS analysis so far at a later stage or during discrete project development. This may increase the economic benefits associated with TDNS	High	Med	There is a lack of clarity between the extent and timescales to which TDNS schemes would be able to capture air quality benefits as these may be rectified in advance of decarbonisation schemes being introduced. Consideration will be given during the development of the

			programme of decarbonisation the extent to which these benefit could be captured.
--	--	--	-----------------------------------------------------------------------------------------

APPENDIX 10 – ECONOMIC MODEL SOURCES

The table below outlines the various sources of data used within the TDNS economic model.

Measure	Source
Passenger rolling stock capabilities and consumption rates	TDNS Technical Summary and T1145
Freight rolling stock capabilities and consumption rates	TDNS Technical Summary and T1145
Electrification capital cost	Work from NR Technical Authority and Regional representatives
Battery and hydrogen capital cost	T1199
Passenger rolling stock capital/lease costs	T1145
Passenger timetable and rolling stock allocation	MOIRA 2.2 Wednesday Summer 2019
Freight timetable and rolling stock allocation	Actual running data extract Period 09 18/19 to P04 19/20
Passenger journeys, revenue and mileages	Sept 18- Sept 19 LENNON data
Incremental infrastructure maintenance costs	CP6 VUC and EAUC rates
Rolling stock maintenance	T1145

APPENDIX 11 – ACRONYMS AND GLOSSARY

AC	Alternating Current
APCO	Automatic Power Change Over
BCR	Benefit Cost Ratio
BMU	Battery Multiple Unit
Bo-Bo	Locomotive type with four axles in two individual bogies
Bo-Bo-Bo	Locomotive type with six axles in three individual bogies
C-DAS	Connected – Driver Advisory System
CAZ	Clean Air Zone
CCC	Committee on Climate Change
CEI	Cost Effectiveness Indicator
CMSP	Continuous Modular Strategic Planning
CNG	Compressed Natural Gas
CO ₂	Carbon Dioxide
CO ₂ e	Carbon Dioxide Equivalent
Co-Co	Locomotive type with six axles in two individual bogies
COMAH	Control of Major Accident Hazards
CP(x)	Control Period x
DAP	Decarbonisation Action Plan
DBO	Design-Build-Operate
DBFMO	Design-Build-Finance-Maintain-Operate
DC	Direct Current
DfT	Department for Transport
DMU	Diesel Multiple Unit

EWRCO	East West Rail Company
ECML	East Coast Main Line
EMU	Electric Multiple Unit
F2MN	Felixstowe to the Midlands and North
FOC	Freight Operating Company
GB	Great Britain
GDP	Gross Domestic Product
GEML	Great Eastern Main Line
GHG	Greenhouse Gas
GRIP	Governance of Railway Investment Project
GWML	Great Western Main Line
GWR	Great Western Railway (TOC)
HGV	Heavy Goods Vehicle
HMU	Hydrogen Multiple Unit
HS1	High Speed 1
HS2	High Speed 2
IDF	Investment Decision Framework
IPEMU	Independently Powered Electric Multiple Unit
kA	Kiloamps
km	Kilometres
Km/h	Kilometres per hour
kV	Kilovolts
kWh	Kilowatt Hour
LA	Local Authorities
LNER	London North Eastern Railway (TOC)

LNG	Liquid Natural Gas
LTDP	Long Term Deployment Plan
MAA	Moving Annual Average
MML	Midland Main Line
mph	Miles Per Hour
MTIN	Miles per Technical Incident
NOx	Nitrogen Oxide
NPR	Northern Powerhouse Rail
NPV	Net Present Value
NR	Network Rail
NRDD	Network Rail Design Delivery
NW&C	North West and Central
OCS	Overhead Contact System
O-D	Origin-Destination
OHL	Overhead Line
OLE	Overhead Line Electrification
ORR	Office of Rail and Road
PBC	Programme Business Case
PDFH	Passenger Demand Forecasting Handbook
PRM	Persons of Reduced Mobility
PV	Present Value
PVB	Present Value Benefits
PVC	Present Value Costs
RDG	Railway Delivery Group
RIA	Railway Industry Association

RIDT	Rail Industry Decarbonisation Taskforce
RNEP	Railway Network Enhancements Pipeline
Route Km	Route Kilometre – This is the length of an operational route and does not distinguish between the number of tracks
ROSCO	Rolling Stock Owning Company
RotR	Rules of the Route
RRAP	Road Rail Access Point
RSS	Rolling Stock Strategy
RSSB	Railway Safety and Standards Board
RSSSG	Rolling Stock Strategy Steering Group
RUS	Route Utilisation Study
SBTi	Science Based Targets initiative
SNTB	Sub-National Transport Body
SO	System Operator
SOBC	Strategic Outline Business Case
SRFI	Strategic Rail Freight Interchange
STK	Single Track Kilometre – This is the absolute length of track in a route kilometre. i.e. one route km of twin track railway is 2 STKs
TAC	Track Access Charge
TAG	Transport Appraisal Guidance
TDNS	Traction Decarbonisation Network Strategy
TDP	Transport Decarbonisation Plan
TfL	Transport for London
TfN	Transport for the North
TfW	Transport for Wales

TOC	Train Operating Company
TPU	TransPennine Upgrade
TS	Transport Scotland
TSI	Technical Standard for Interoperability
UK	United Kingdom
ULEZ	Ultra-Low Emission Zone
UNFCCC	United Nations Framework Committee of Climate Change
VTAC	Variable Track Access Charge
V	Volts
W&W	Wales and Western
WCML	West Coast Main Line
WG	Welsh Government
WISP	Whole Industry Strategic Plan
WLCBC	Whole-Lifecycle Cost-Benefit-Carbon
WMT	West Midlands Trains (TOC)
WRACA	Weather Resilience and Climate Adaptation
